



Rotating Vane Flow Meter for liquids



measuring
•
monitoring
•
analysing

DRG

Model: DRG-...L



Model: ADI-1



Model: DRG-...C



- Measuring ranges:
0.5 - 12 ... 10 - 140 l/min water
- Measuring accuracy:
±3% of full scale
- p_{max} : 40 bar; t_{max} : 80 °C
- Connection:
G 1/8, G 1/4, G 1/2, G 3/4, G 1 female,
1/8" NPT, 1/4" NPT, 1/2" NPT,
3/4" NPT, 1" NPT female
- Material:
brass, stainless steel, PP
- Viscosity range: low viscous
- Output:
pulses, 4 - 20 mA, LED display,
pointer indication



S4

KOBOLD companies worldwide:

ARGENTINA, AUSTRALIA, AUSTRIA, BELGIUM, BULGARIA, CANADA, CHILE, CHINA, COLOMBIA, CZECHIA, EGYPT, FRANCE, GERMANY, GREAT BRITAIN, HUNGARY, INDIA, INDONESIA, ITALY, MALAYSIA, MEXICO, NETHERLANDS, PERU, POLAND, REPUBLIC OF KOREA, ROMANIA, SINGAPORE, SPAIN, SWITZERLAND, TAIWAN, THAILAND, TUNISIA, TURKEY, USA, VIETNAM

KOBOLD Messring GmbH
Nordring 22-24
D-65719 Hofheim/Ts.
Head Office:
+49(0)6192 299-0
+49(0)6192 23398
info.de@kobold.com
www.kobold.com

Description

KOBOLD rotating vane flow meters series DRG are used for measuring and monitoring low viscous liquids. Series DRG flow meters are working according the well-known rotating vane principle. A magnet fitted in the vane and hermetically sealed from the medium transfers non-contacting the rotary motion to a Hall-effect sensor mounted in the housing. The sensor converts the rotary motion which is proportional to the flow to a frequency signal. A series-connected electronics unit converts the signal to an analogue output, limit contacts or display.

Fields of Application

- Cooling water monitoring
- Agricultural machinery
- PCB board industry

Electrical Connection

DRG-...F., DRG-...Z., DRG-...L3... 3-wire

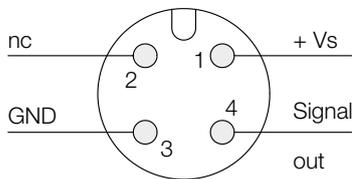

DRG-...L342... 2-wire

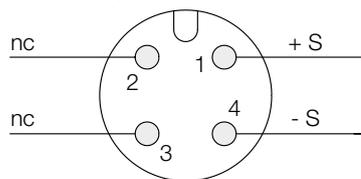

DRG-...L4...

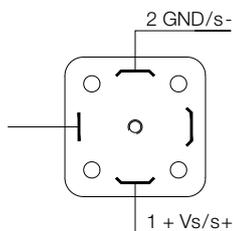

DRG-...C...

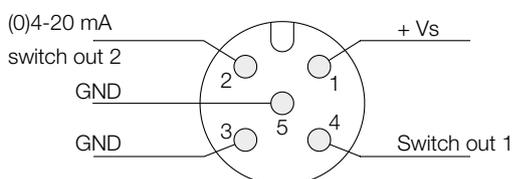

Technical Details

Material combinations:	see order details
Max. operating pressure:	see order details
Max. temperature:	see order details
Measuring accuracy:	±3% of full scale
Electrical connection:	plug connector DIN 43 650, plug connector M12x1
Pressure loss:	max. 1 bar at max. range
Protection:	IP 65

Electronics

● **Frequency output (...F300)**

Power supply:	12-28 V _{DC}
Power consumption:	10 mA
Pulse output:	PNP, open collector max. 25 mA
Electrical connection:	plug connector M12x1

● **Frequency output with frequency divider**

Power supply:	24 V _{DC} ±20%
Power consumption:	15 mA
Pulse output:	PNP, open collector, max. 25 mA
Electrical connection:	plug connector M12x1
Division ratio:	1 ... 1/128, factory set

● **Analogue output (Option plug-on display)**

Power supply:	24 V _{DC} ±20%
Output:	0-20 mA or 4-20 mA, 2-wire or 3-wire
Max. load:	500 Ω
Electrical connection:	plug connector M12x1 or DIN 43650
Option:	plug-on display (with plug connector DIN 43650 and output 4-20 mA only), 2-wire

● **Compact electronics**

Display:	3-segment LED
Analogue output:	(0)4...20 mA adjustable, max. 500 W
Switching outputs:	1 (2) semiconductor PNP or NPN factory set
Contact operation:	N/C / N/O contact frequency programmable
Setting:	with 2 buttons
Power supply:	24 V _{DC} ±20%, 3-wire technology approx. 100 mA
Electrical connection:	plug connector M12x1

● **Pointer indication with analogue output**

Housing:	aluminium
Display:	moving-coil instrument, 240° display
Power supply:	24 V _{DC} ±20%
Output:	0-20 mA or 4-20 mA, 3-wire
Max. load:	250 Ω
Electrical connection:	plug connector M12x1



Order Details (Example: DRG-1 1 05 G1 F300)

Measuring range		Orifice diameter [mm]	Model	Connection		Evaluating electronics
Water [l/min]	approx. frequency [Hz] at F.S.			Standard female	Special female	
0.5-12	120	6	DRG-1X05..	..G1..=G 1/8"	..N1..= 1/8" NPT	Evaluating electronics Frequency output ..F300 = Frequency output, plug connector M12 x 1 ..F320 = Frequency divider 1:2, plug connector M12 x 1 ..F340 = Frequency divider 1:4, plug connector M12 x 1 ..F390 = Frequency divider 1...1/128, plug connector M12x 1 Analogue output ..L303 = 0-20 mA output, 3-wire, M12 x 1 plug connector ..L342 = 4-20 mA output, 2-wire, M12 x 1 plug connector ..L343 = 4-20 mA output, 3-wire, M12 x 1 plug connector ..L442 = 4-20 mA output, 2-wire, plug connector DIN 43 650 Compact electronics* ..C30R = LED display, 2 x open Collector, PNP, plug connector M12 x 1 ..C30M = LED display, 2 x open Collector, NPN, plug connector M12 x 1 ..C34P = LED display, 4-20 mA, 1 x open Collector PNP, plug connector M12 x 1 ..C34N = LED display, 4-20 mA, 1 x open Collector NPN, plug connector M12 x 1 Pointer indication* ..Z300 = 240° pointer indication, 0-20 mA, plug connector M12x1 ..Z340 = 240° pointer indication, 4-20 mA, plug connector M12x1
0.5-25	217	6	DRG-1X10..	..G2..=G 1/4"	..N2..= 1/4" NPT	
1-30	217	8	DRG-1X15..	..G2..=G 1/4"	..N2..= 1/4" NPT	
1-30	190	7	DRG-1X15..	..G4..=G 1/2"	..N4..= 1/2" NPT	
2-45	215	8	DRG-1X20..	..G4..=G 1/2" ..G5..=G 3/4" ..G6..=G 1"	..N4..= 1/2" NPT ..N5..= 3/4" NPT ..N6..= 1" NPT	
5-90	265	12	DRG-1X25..	..G4..=G 1/2" ..G5..=G 3/4" ..G6..=G 1"	..N4..= 1/2" NPT ..N5..= 3/4" NPT ..N6..= 1" NPT	
5-140	116	16	DRG-1X30..	..G5..=G 3/4"	..N5..= 3/4" NPT	
10-140	180	16	DRG-1X35..	..G6..=G 1"	..N6..= 1" NPT	

* Please specify flow direction in writing.

Material Combinations (Please enter order code instead of X "model")

Device parts	Order code: 1	Order code: 2	Order code: 4	Order code: 5	Order code: 8	Order code: 9
Housing	Brass	Brass	1.3955	1.3955	Polypropylene	Polypropylene
Housing cover	Polysulfone	Brass	Polysulfone	1.4404	Polypropylene	Polysulfone
Seal	NBR	NBR	FPM	FPM	NBR	NBR
Rotating vane	PTFE	PTFE	PTFE	PTFE	PTFE	PTFE
Axle	Ceramic	Ceramic	Ceramic	Ceramic	Ceramic	Ceramic
Bearing	PTFE	PTFE	PTFE	PTFE	PTFE	PTFE
p _{max} *	16 bar	40 bar	16 bar	40 bar	7 bar	7 bar
t _{max} *	80 °C	80 °C	80 °C	80 °C	80 °C	80 °C
Sensor Weight	580 g	580 g	480 g	480 g	120 g	120 g



Plug-on Display

for model DRG...L442 (with 4-20 mA output and DIN plug connector)

Description	Order number
4-digit LED, connector DIN 43650, 2-wire, supply through analogue output	AUF-1000
as above however with additional open collector output	AUF-1001

Electronic weight

Frequency output: approx. 35 g
 Analogue output (...L3...): approx. 35 g
 Analogue output (...L4...): approx. 100 g
 Compact electronics: approx. 650 g
 Pointer indication: approx. 450 g

Dimensions

Model: DRG-F3.. (with frequency output), **DRG-..L3..** (with analogue output)

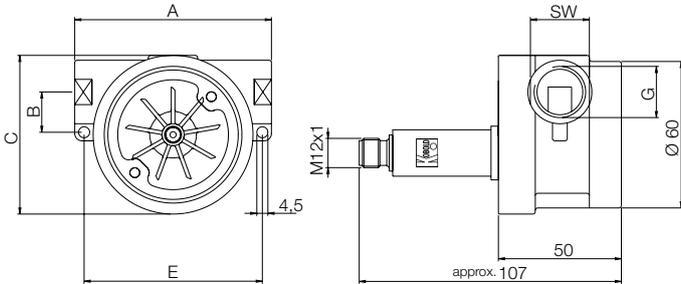

G	A	B	C	E	SW
1/8	80	16.5	63.0	72.5	24
1/4	80	16.5	63.0	72.5	24
1/2	80	16.5	63.0	72.5	24
3/4	100	25.0	69.5	90.0	38
1	100	25.0	69.5	90.0	38

Model: DRG-...L442 (with analogue output and plug-on display)

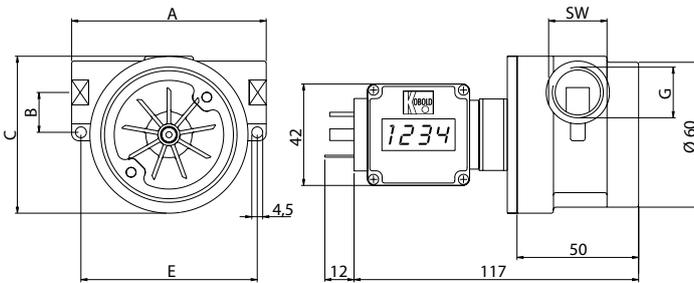

G	A	B	C	E	SW
1/8	80	16.5	63.0	72.5	24
1/4	80	16.5	63.0	72.5	24
1/2	80	16.5	63.0	72.5	24
3/4	100	25.0	69.5	90.0	38
1	100	25.0	69.5	90.0	38

Model: DRG-...C (with compact electronics)

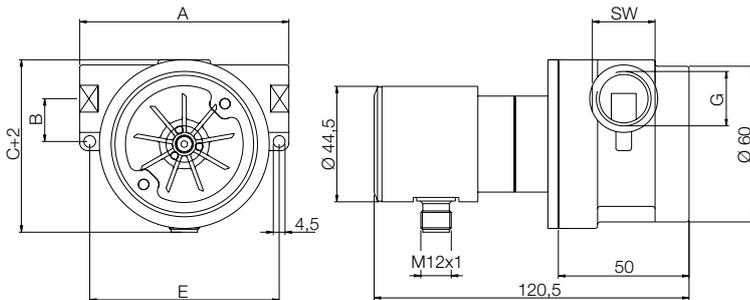

G	A	B	C	E	SW
1/8	80	16.5	63.0	72.5	24
1/4	80	16.5	63.0	72.5	24
1/2	80	16.5	63.0	72.5	24
3/4	100	25.0	69.5	90.0	38
1	100	25.0	69.5	90.0	38

Model: DRG-...Z (with pointer indication)

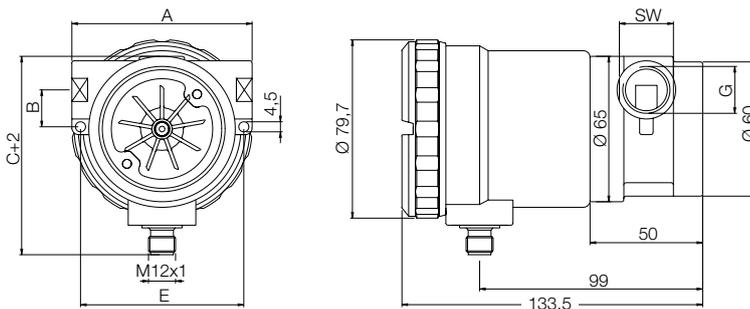

G	A	B	C	E	SW
1/8	80	16.5	63.0	72.5	24
1/4	80	16.5	63.0	72.5	24
1/2	80	16.5	63.0	72.5	24
3/4	100	25.0	69.5	90.0	38
1	100	25.0	69.5	90.0	38