

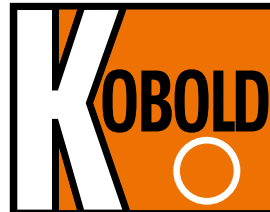

Orifice Plate and Orifice Flange



measuring
•
monitoring
•
analysing

KPL

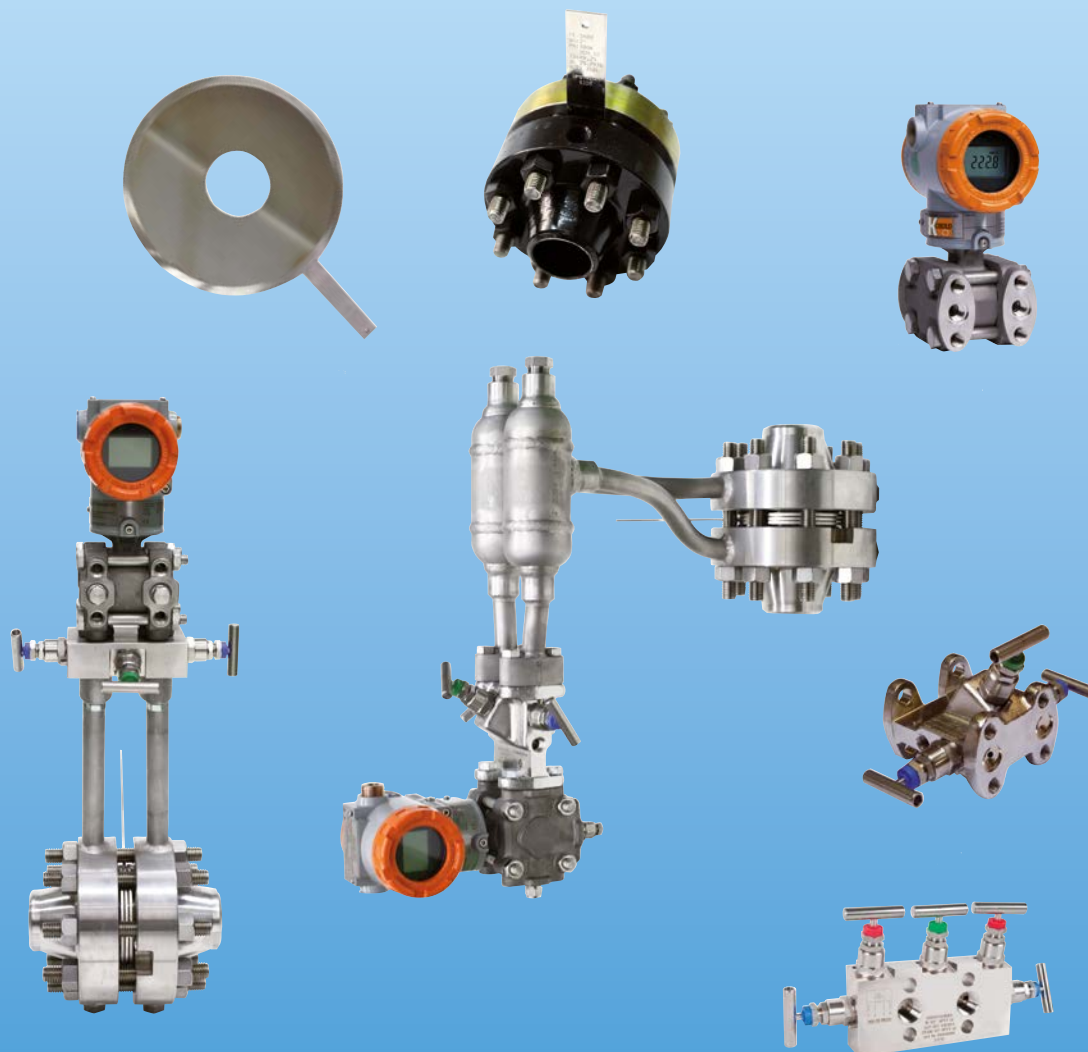

- Sizes: DN 50 ... DN 600, 2" ... 24" ASME
- p_{\max} : PN 420 or Class 2500; t_{\max} : +500 °C (930 °F), higher on request
- Material: stainless steel, carbon steel, others on request



SS

KOBOLD companies worldwide:

ARGENTINA, AUSTRIA, BELGIUM, BULGARIA, CANADA, CHILE, CHINA, COLOMBIA, CZECHIA, DOMINICAN REPUBLIC, EGYPT, FRANCE, GERMANY, GREAT BRITAIN, HUNGARY, INDIA, INDONESIA, ITALY, MALAYSIA, MEXICO, NETHERLANDS, PERU, POLAND, ROMANIA, SINGAPORE, SOUTH KOREA, SPAIN, SWITZERLAND, TAIWAN, THAILAND, TUNISIA, TURKEY, USA, VIETNAM

KOBOLD Messring GmbH
Nordring 22-24
D-65719 Hofheim/Ts.
Head Office:
+49(0)6192 299-0
+49(0)6192 23398
info.de@kobold.com
www.kobold.com

Description

If a pipeline (through which a medium flows) is reduced at a particular point by a cross-sectional constriction, the flow speed of the measured medium is increased at that point. According to Bernoulli's energy equation and the law of continuity, the total flow head (dynamic velocity head and static pressure head) is constant.

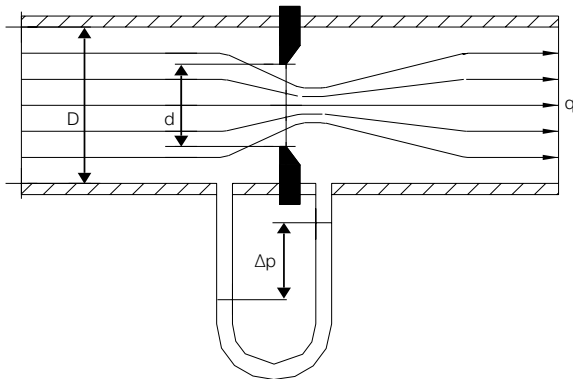

The increase in speed at the constriction causes a reduction in the static head. The resulting pressure drop is called the differential pressure head; it is a measure of the flow (volume per unit of time or mass per unit of time).

The flow rate q is given by: $q = c\sqrt{\Delta p}$

The flow rate (q) is a function of the square root of the differential pressure head (Δp), where c is the coefficient of flow rate determined by the shape of the differential pressure transducer and the operating data. The pipeline may be constricted with orifice plates.

Fields of application

Orifice primary elements are used for economical and reliable flow measurement of liquids, gases or steam. During measurement, the medium should be in one pure phase and flow through pipes with circular cross-section running full. DIN EN ISO 5167-2 is not applicable to the measurements of pulsating flow. The orifice plates require little or no maintenance, as there are no moving parts in the measurement stream.

Metering unit design

The entire metering unit comprises of the following:

- **Transmitter**

The transmitter converts the differential pressure signal into a standard output signal. To generate a linear signal, we recommend a differential pressure transmitter with internal square-root extraction, e.g. PAD model.

- **Primary element** (e.g. an orifice with flange tapping, corner tapping or D-D/2 pressure tapping etc.)

- **Orifice Plates (Model KPL-B...)**

The orifice plate with welded handle model KPL-B is supplied with plain raised face for fitting between pipeline flanges. It generates and sustains the differential pressure required for flow measurement. The differential pressure head is tapped in the flange or in the pipeline at a particular distance from the orifice plate. This distance is included in the calculations for the plate. The plates are dimensioned to suit prevailing service conditions. The orifice plates have no mounting rings; they are fitted between pipeline flanges.

The various orifice plate designs depend on application and are summarised below:

Orifice Plates according to DIN EN ISO 5167- 2 Standard

Concentric Orifice Plate (Figure 1)

The essential characteristics are a sharp inlet edge, a cylindrical hole of a specific length and a downstream conically tapered outlet.

The limit of use:

- $d > 12.5 \text{ mm}$
- $D < 500 \text{ mm}$
- $0.1 < \beta < 0.75$
- $Re > 10^5 \beta$

Pressure taps only Corner-Taps.

Bidirectional Orifice Plate (Figure 2)

Orifice plates with a cylindrical measuring-plate opening are used for an alternating, bidirectional flow direction or when regulations other than DIN don't specify a bevel.

The limit of use: as for concentric

Quarter Circle Nozzle (Figure 3)

The dimensionless Reynolds number has special significance in the flow throughput measurement and serves to characterize the flow. It is dependent upon the pipeline diameter, the flow rate and the viscosity of the medium. Standard orifice plates cannot be used for small Reynolds numbers (e.g. in the case of oil measurement). Quarter-circle nozzles are used in these cases.

The limit of use:

- $d > 15 \text{ mm}$
- $D < 500 \text{ mm}$
- $0.245 < \beta < 0.6$
- $Re < 10^5 \beta$

Pressure taps only Corner-Taps.

Conical Entrance Orifice (Figure 4)

The conical entrance orifice is used for very small Reynolds numbers.

Calculation and designing are based on norm ISO-5167- ISO/TR-15377.

The limit of use:

- $d > 6 \text{ mm}$
- $D < 500 \text{ mm}$
- $0.1 < \beta < 0.316$
- $80 < Re < 2 \times 10^5 \beta$

Pressure taps only Corner-Taps.



Segmental Orifice (Figure 5)

If there are solids or gases in a medium, they could accumulate in front of the orifice and lead to erroneous measurement. The segmented orifices eliminate this disadvantage to a great extent. The measurement cross-section is not circular and concentric, but instead segment shaped. It provides complete clearance in the lower or upper part of the pipe. Existing solids in liquids (aperture at the bottom) or gas bubbles in liquids (aperture at the top) get free flow in the undisturbed part of the pipeline.

Calculation and designing are based on norm ISO-5167- ISO/TR-15377.

The limit of use:

- d > 30 mm
- 100 < D < 350 mm
- 0.3 < β < 0.8
- Re > 10000

Pressure taps only Flange-Taps.

Excentric Orifice (Figure 6)

If there are solids or gases in a medium, they could accumulate in front of the orifice and lead to erroneous measurement. The segmented orifices eliminate this disadvantage to a great extent. The measurement cross-section is circular and not concentric. It provides complete clearance in the lower or upper part of the pipe. Existing solids in liquids (aperture at the bottom) or gas bubbles in liquids (aperture at the top) get free flow in the undisturbed part of the pipeline.

Calculation and designing are based on norm ISO-5167- ISO/TR-15377.

The limit of use:

- d > 50 mm
- 100 < D < 1000 mm
- 0.46 < β < 0.84
- $2 \times 10^5 \beta^2 < Re < 10^6 \beta$

Pressure taps only Flange-Taps.

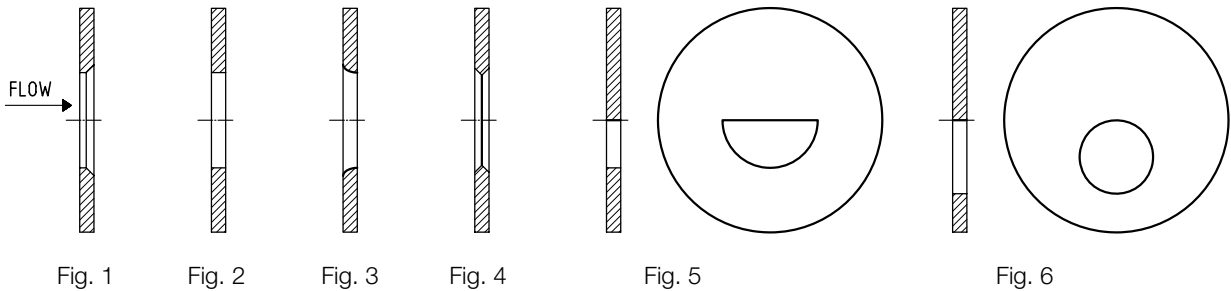

| Design | Bore type | Reynolds No./Application (approx. numbers) |
|--------|-----------------------|---|
| 1 | Concentric (standard) | Re > 5000 for 0.1 < β < 0.56 Re > 16000 β^2 for β > 0.56 |
| 2 | Bidirectional | Re > 5000 for 0.1 < β < 0.56 Re > 16000 β^2 for β > 0.56 |
| 3 | Quarter Circle | 500 < Re < 5000 |
| 4 | Conical Entrance | 80 < Re < 500 |
| 5 | Segmental | Re > 5000 |
| 6 | Excentric | Re > 5000 for 0.1 < β < 0.56 Re > 16000 β^2 for β > 0.56 |

Dimensions (Orifice Plate)

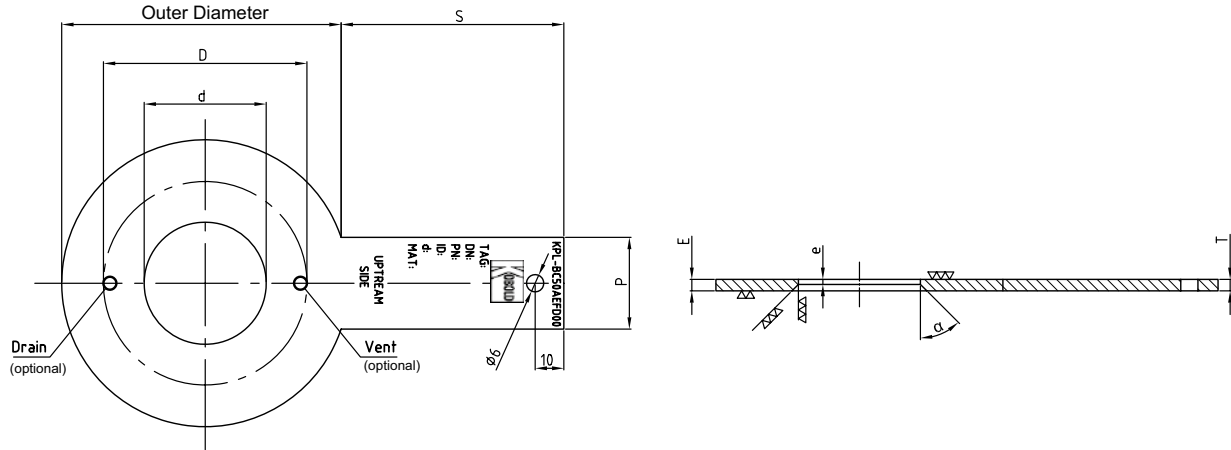

Definitions as per DIN EN ISO 5167

Diameter 'D':

Inner Pipe diameter upstream (or diameter of upstream cylinder in case of classic venturi tube) under process conditions.

Plate Thicknesses 'E' and 'e': as per DIN EN ISO 5167-2

The thickness 'e' of the orifice shall be between 0.005 D and 0.02 D. The difference between the values of 'e' measured at any point on the orifice shall not be greater than 0.001 D.

The thickness 'E' of the plate shall be between 'e' and 0.05 D.

However, when $50 \text{ mm} \leq D \leq 64 \text{ mm}$, a thickness 'E' up to 3.2 mm is acceptable.

If $D \geq 200 \text{ mm}$, the difference between the values of 'E' measured at any point of the plate shall not be greater than 0.001 D.

If $D < 200 \text{ mm}$, the difference between the values of 'E' measured at any point of the plate shall not be greater than 0.2 mm.

Orifice diameter (d):

The diameter 'd' shall in all cases be greater than or equal to 12.5 mm. The diameter ratio, $\beta = d/D$, shall be always greater than or equal to 0.10 and less than or equal to 0.75. Within these limits, the value of β may be chosen by the user/manufacturer.

Angle of bevel 'α': It should be $45^\circ \pm 15^\circ$

Drain / Vent Hole:

Orifice Plates may also be delivered with drain/vent holes. This option is only available for mounting in horizontal pipes. Outside edge of drain/vent hole is tangent to the inner pipe diameter.

- Vent Hole is used for liquids with gas bubbles
- Drain Hole is used for gases with condensation
See orifice plate dimensional drawing for positioning of these holes

| Nominal Diameter | E | e | S | P | T |
|------------------|----|-----|-----|----|----|
| DN 50 (2") | 3 | 1 | 125 | 32 | 3 |
| DN 65 (2½") | 3 | 1.5 | 125 | 32 | 3 |
| DN 80 (3") | 3 | 1.5 | 125 | 32 | 3 |
| DN 100 (4") | 3 | 1.5 | 125 | 40 | 3 |
| DN 150 (6") | 3 | 1.5 | 140 | 40 | 3 |
| DN 200 (8") | 6 | 3.5 | 140 | 38 | 6 |
| DN 250 (10") | 6 | 3.5 | 140 | 45 | 6 |
| DN 300 (12") | 6 | 3.5 | 140 | 45 | 6 |
| DN 350 (14") | 6 | 3.5 | 140 | 45 | 10 |
| DN 400 (16") | 10 | 6 | 150 | 45 | 10 |
| DN 450 (18") | 10 | 6 | 150 | 50 | 10 |
| DN 500 (20") | 10 | 6 | 150 | 50 | 10 |
| DN 600 (24") | 12 | 8 | 150 | 50 | 12 |

Marking Orifice Plate:

The following data is written on the side facing upstream:

- Tag Nr
- Pipeline nominal size (DN)
- Pressure rating (PN)
- Pipe Inner diameter (D)
- Orifice diameter (d)
- Material
- Upstream side

Recommended Straight Run Requirements:

as per DIN EN ISO 5167-2 (see section "Flow Conditioner")



| DN | Orifice Plate Outer Diameter (max.) for flanges according to EN 1092-1 Form B1 [mm] | | | | | | Approx. Weight [kg] | | | | | |
|-----|---|------|------|------|------|-------|---------------------|-------|-------|-------|-------|-------|
| | PN10 | PN16 | PN25 | PN40 | PN63 | PN100 | PN10 | PN16 | PN25 | PN40 | PN63 | PN100 |
| 50 | 107 | 107 | 107 | 107 | 113 | 119 | 0.21 | 0.21 | 0.21 | 0.21 | 0.24 | 0.27 |
| 65 | 127 | 127 | 127 | 127 | 138 | 144 | 0.3 | 0.3 | 0.3 | 0.3 | 0.36 | 0.39 |
| 80 | 142 | 142 | 142 | 142 | 148 | 154 | 0.38 | 0.38 | 0.38 | 0.38 | 0.41 | 0.45 |
| 100 | 162 | 162 | 168 | 168 | 174 | 180 | 0.66 | 0.66 | 0.71 | 0.71 | 0.76 | 0.91 |
| 125 | 192 | 192 | 194 | 194 | 210 | 217 | 0.92 | 0.92 | 0.94 | 0.94 | 1.1 | 1.18 |
| 150 | 218 | 218 | 224 | 224 | 247 | 257 | 1.78 | 1.78 | 1.88 | 1.88 | 2.29 | 2.48 |
| 200 | 273 | 273 | 284 | 290 | 309 | 324 | 2.8 | 2.8 | 3.03 | 3.16 | 3.56 | 3.94 |
| 250 | 328 | 329 | 340 | 352 | 364 | 391 | 4.04 | 4.06 | 4.34 | 4.56 | 4.98 | 5.74 |
| 300 | 378 | 384 | 400 | 417 | 424 | 458 | 5.37 | 5.54 | 6.01 | 6.53 | 6.75 | 7.88 |
| 350 | 438 | 444 | 457 | 474 | 486 | 512 | 7.21 | 7.4 | 7.84 | 8.44 | 8.87 | 9.85 |
| 400 | 489 | 495 | 514 | 546 | 543 | 572 | 14.97 | 15.34 | 16.54 | 18.66 | 18.46 | 20.48 |
| 450 | 539 | 555 | 565 | 571 | - | - | 18.19 | 19.28 | 19.98 | 20.41 | - | - |
| 500 | 594 | 617 | 624 | 628 | 657 | 704 | 22.09 | 23.83 | 24.37 | 24.69 | 27.02 | 31.02 |
| 600 | 695 | 734 | 731 | 747 | 764 | 813 | 36.28 | 40.47 | 40.14 | 41.92 | 43.84 | 49.65 |

| Line Size [inch] | Orifice Plate Outer Diameter (max.) for flanges according to ASME B 16.5 and B 16.36* [inch (mm)] | | | | | Approx. Weight [kg] | | | | |
|------------------|---|-----------------|-----------------|-----------------|-----------------|---------------------|-------|-------|--------|--------|
| | 300 # | 600 # | 900 # | 1500 # | 2500 # | 300 # | 600 # | 900 # | 1500 # | 2500 # |
| 2" | 4.375 (111.13) | 4.375 (111.13) | 5.625 (142.88) | 5.625 (142.88) | 5.750 (146.5) | 0.21 | 0.21 | 0.21 | 0.21 | 0.24 |
| 2½" | 5.125 (130.18) | 5.125 (130.18) | 6.500 (165.1) | 6.500 (165.1) | 6.625 (168.28) | 0.3 | 0.3 | 0.3 | 0.3 | 0.36 |
| 3" | 5.875 (149.23) | 5.875 (149.23) | 6.625 (168.28) | 6.87 (174.6) | 7.750 (196.85) | 0.38 | 0.38 | 0.38 | 0.38 | 0.41 |
| 4" | 7.125 (180.98) | 7.625 (193.68) | 8.125 (206.38) | 8.250 (209.55) | 9.25 (234.9) | 0.66 | 0.66 | 0.71 | 0.71 | 0.76 |
| 6" | 9.875 (250.83) | 10.500 (266.7) | 11.375 (288.93) | 11.125 (282.58) | 12.500 (317.5) | 1.78 | 1.78 | 1.88 | 1.88 | 2.29 |
| 8" | 12.125 (307.98) | 12.625 (320.68) | 14.125 (358.78) | 13.875 (352.43) | 15.250 (387.35) | 2.8 | 2.8 | 3.03 | 3.16 | 3.59 |
| 10" | 14.250 (361.95) | 15.750 (400.05) | 17.125 (434.98) | 17.125 (434.98) | 18.750 (476.25) | 4.04 | 4.06 | 4.34 | 4.56 | 4.98 |
| 12" | 16.625 (422.26) | 18.000 (457.2) | 19.625 (498.48) | 20.500 (520.7) | 21.625 (549.28) | 5.37 | 5.54 | 6.01 | 6.53 | 6.75 |
| 14" | 19.125 (485.78) | 19.37 (492.1) | 20.500 (520.7) | 22.750 (577.85) | - | 7.21 | 7.4 | 7.84 | 8.44 | 8.87 |
| 16" | 21.250 (539.75) | 22.25 (565.15) | 22.625 (574.68) | 25.250 (641.35) | - | 14.97 | 15.34 | 16.54 | 18.66 | 18.46 |
| 18" | 23.5 (596.9) | 24.12 (612.7) | 25.125 (638.2) | 27.755 (705.0) | - | 18.19 | 19.28 | 19.98 | 20.41 | 21 |
| 20" | 25.75 (654.1) | 26.87 (682.6) | 27.5 (698.5) | 29.75 (755.6) | - | 22.09 | 23.83 | 24.37 | 24.69 | 27.02 |
| 24" | 30.5 (774.7) | 31.125 (790.6) | 33 (838.2) | 35.500 (901.7) | - | 36.28 | 40.47 | 40.14 | 41.92 | 43.84 |

* only for RF flanges NO RTJ

• **Orifice Flange Union (Model KPL-F...)**

Mechanical construction of the orifice depends also on the type of pressure tapping. Orifice Flange Union comprises of weld-neck flanges for welding in the pipe (flanges with pressure taps) and the exchangeable orifice plate (standard type of pressure tapping). Other types of flanges (slip-on and threaded orifice flanges) and pressure tapplings described in DIN EN ISO 5167 such as corner tapping with single bore, corner tapping with annular chamber, Meter Run, D-D/2 tapping and pipe tapping are available on request.

Orifice flanges are widely used in conjunction with orifice plates for measuring the rate of flow of liquids, gases and steam.

Flange tapping (Figure 6)

The accurately positioned pressure taps for connecting the flow measuring instruments are located at a distance of 1" (25.4 mm) before (+) and after (-) the orifice. These built-in taps also reduce field installation labour necessary for welding, drilling and/or tapping pressure taps on the flow line itself. Orifice flanges are provided complete with nuts, bolts, gaskets and plugs for installation. Usually the tapping is realised by a bore through the flange. Standardized measuring flanges are available for flange tapping (EN 1092-1 or ASME B 16.36). The orifice plate is exchangeable. Flange tapping is preferred wherever ASME applies.

Flange tapping is for flanges with raised face, PN10...PN100 and sizes DN50...DN600 for flanges according to DIN EN 1092-1 or Cl.300...Cl.2500 and sizes 2"...24" for flanges according to ASME B 16.36 respectively.

D-D/2 tapping (Figure 7)

The tapping connections are fitted in the pipe. Clearance $l_1 = D$ and $l_2 = D/2$, whereas 'D' is the inner pipe diameter.

Corner tapping (Figure 8)

The pressure is tapped immediately before (+) and after (-) the orifice. It is used when the flange leaf cannot be drilled, e.g. with PN6, or when pipeline tapping is to be avoided and preferred wherever DIN EN is valid.

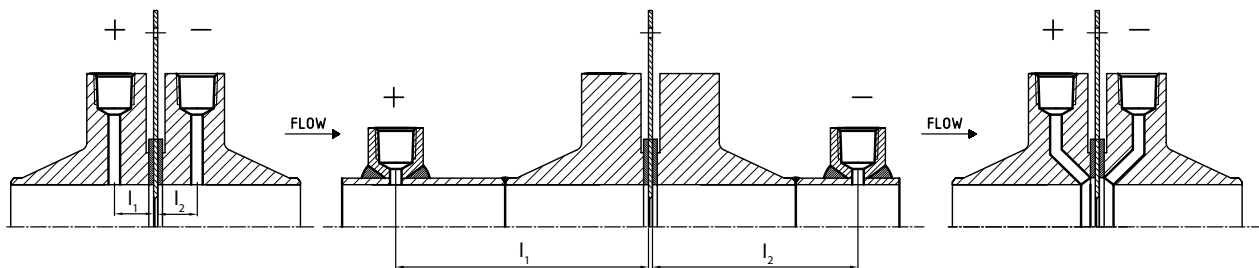

Fig. 6

Fig. 7

Fig. 8

Orifice Flange Union (DIN EN 1092-1 Form B1 flanges, flange or corner tapping)

Construction: DIN EN 1092-1: Orifice plate acc. to DIN EN ISO 5167-2 (standard) completely assembled with flanges, screws and gaskets. Sealing type smooth. Weld neck flange. Orifice calculation according to API (AGA-3) on request

Pressure tap connections: 2 x 1/2" NPT and 180° apart tapings in each flange are provided as standard, one with a plug.
The tap hole diameter is
6.35 mm for DN50 and DN65
9.6 mm for DN80 size and
12.7 mm for DN100 and larger sizes.

Pressure taps location: 0° (standard). Angle taps according to DIN EN ISO 5167-2 on request.

Sealing surface (orifice plate): smooth acc. to DIN EN ISO 5167-2

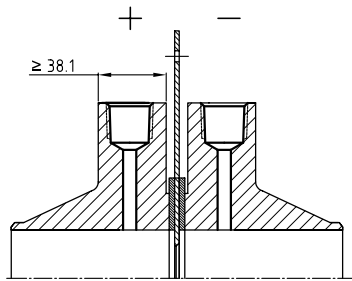

Flange tap

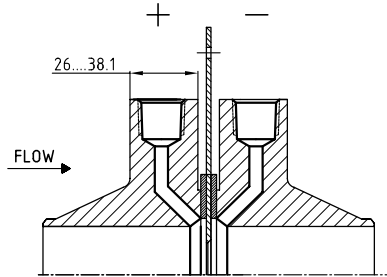

Corner tap

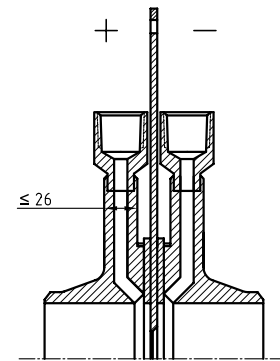

Corner tap with accessories

| D [mm] | Flanges according to DIN EN 1092-1 Form B1 Type 11 L [mm] | | | | | | Approx. Weight [kg] | | | | | |
|--------|---|------|------|------|------|-------|---------------------|--------|--------|--------|--------|--------|
| | PN10 | PN16 | PN25 | PN40 | PN63 | PN100 | PN10 | PN16 | PN25 | PN40 | PN63 | PN100 |
| 50 | 101 | 101 | 107 | 107 | 135 | 148 | 6.58 | 6.58 | 7.24 | 7.24 | 11.57 | 15.51 |
| 65 | 101 | 101 | 115 | 115 | 147 | 164 | 7.76 | 7.76 | 10.25 | 10.25 | 16.03 | 22.70 |
| 80 | 111 | 111 | 127 | 127 | 155 | 168 | 10.84 | 10.84 | 12.67 | 12.67 | 18.41 | 25.43 |
| 100 | 115 | 115 | 141 | 141 | 167 | 192 | 12.80 | 12.80 | 18.41 | 18.41 | 26.84 | 42.37 |
| 125 | 121 | 121 | 147 | 147 | 187 | 222 | 16.55 | 16.55 | 25.96 | 25.96 | 40.40 | 63.39 |
| 150 | 121 | 121 | 161 | 161 | 201 | 242 | 22.81 | 22.81 | 33.45 | 33.45 | 59.41 | 80.87 |
| 200 | 138 | 138 | 174 | 190 | 234 | 274 | 32.31 | 34.14 | 49.82 | 61.60 | 99.20 | 133.34 |
| 250 | 150 | 154 | 190 | 224 | 264 | 328 | 44.55 | 49.99 | 69.74 | 94.46 | 129.77 | 205.37 |
| 300 | 150 | 170 | 198 | 244 | 294 | 354 | 51.89 | 63.43 | 92.45 | 131.41 | 158.71 | 305.50 |
| 350 | 150 | 178 | 214 | 264 | 314 | 392 | 70.54 | 90.79 | 135.25 | 185.02 | 253.54 | 437.85 |
| 400 | 162 | 188 | 238 | 288 | 338 | - | 97.44 | 124.85 | 185.31 | 267.77 | 342.15 | - |
| 450 | 162 | 184 | 238 | 288 | - | - | 116.31 | 130.37 | 225.39 | 296.43 | - | - |
| 500 | 168 | 186 | 268 | 298 | - | - | 133.52 | 195.46 | 285.35 | 366.21 | - | - |
| 600 | 184 | 196 | 270 | 320 | - | - | 186.72 | 291.41 | 358.13 | 597.52 | - | - |

Example: Orifice Flange Union (DIN EN 1092-1 flanges, corner tapping, with accessories), compact version, prepared for assembly with DP Transmitter

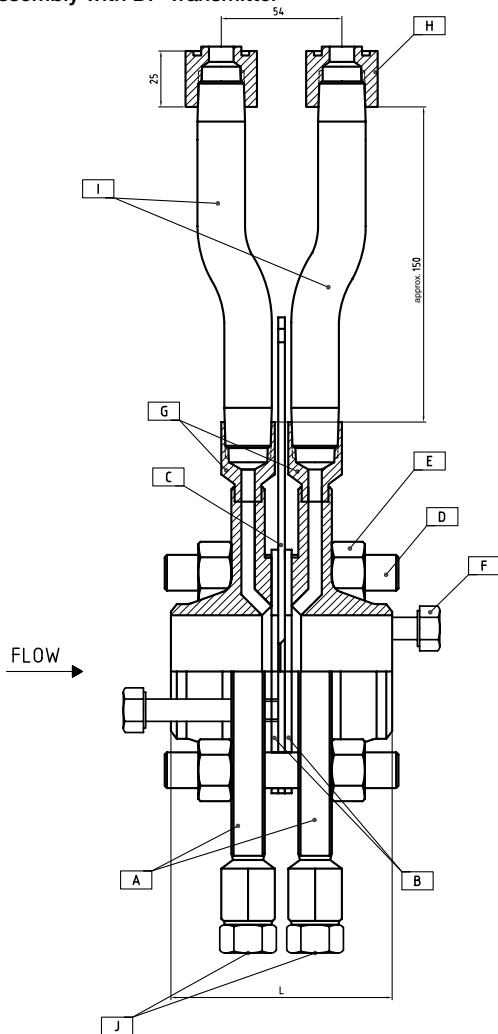

| Position | Description | Material |
|----------|---------------------------------------|---------------------------|
| A | Flange DIN EN-1092-1 Type 11 Form B 1 | carbon steel or st. steel |
| B | Gasket spirometalic | spirometalic |
| C | Orifice plate | 1.4404 |
| D | Screw | carbon steel/1.4404 |
| E | Nuts | carbon steel/1.4404 |
| F | Extractor screw | carbon steel/1.4404 |
| G | Pressure Taps x 2 at 180° for flange | 1.4404 |
| H | Oval flange | 1.4401 |
| I | Nipple | 1.4404 |
| J | Plug | carbon steel or st. steel |

Example: Orifice Flange Union (DIN EN 1092-1 flanges, corner tapping, with accessories), remote version

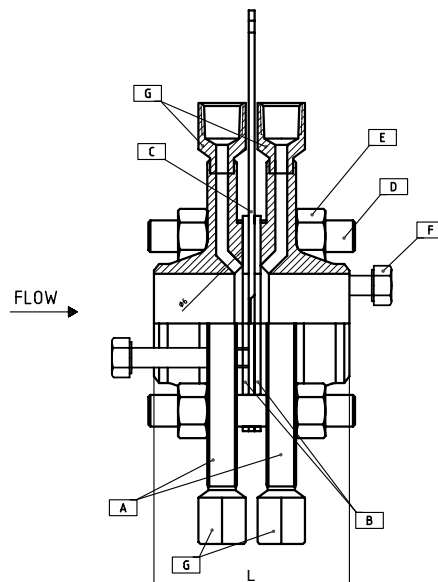

**Orifice Flange Union
(ASME B16.36 flanges, flange tapping)**



Pressure tap connections: 2 x 1/2" NPT and 180° apart tapings in each flange are provided as standard, one with a plug. The tap hole diameter is 1/4" for 2" and 2 1/2" size, 3/8" for 3" size, 1/2" for 4" and larger sizes.

Pressure taps location: 0° (standard). Angle taps according to DINEN ISO 5167-2 on request.

Sealing surface: smooth according to DINEN ISO 5167-2 (orifice plate)

Construction: ASME B 16.36: Orifice plate acc. to DINEN ISO 5167-2 (standard) completely assembled with flanges, screws, gaskets and extractor screws/locking plugs. Sealing type smooth (RF). Each flange with 2 x outlet taps 180° displaced, weld neck. Orifice calculation according to API (AGA-3) on request.

Example: Orifice Flange Union (ASME B16.36 flanges, flange tapping), remote version

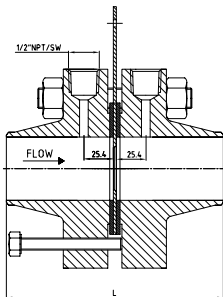

Example: Orifice Flange Union (ASME B16.36 flanges, flange tapping), compact version, prepared for assembly with DP Transmitter

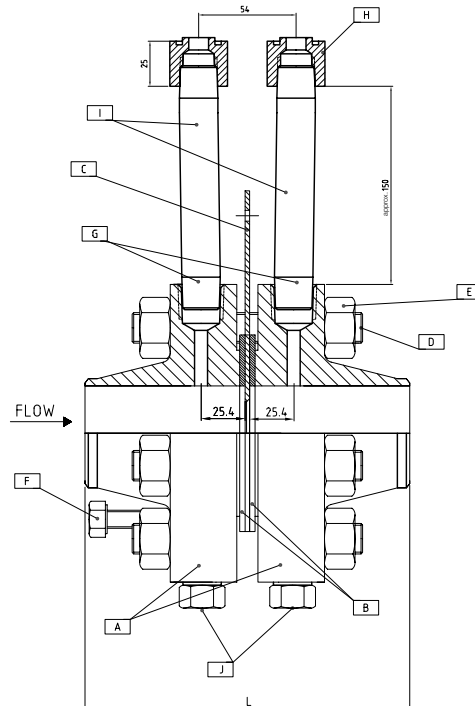

| Position | Description | Material |
|----------|--|---------------------------|
| A | Flange ANSI B16.36 WN RF Ra 125-250 | Carbon steel or st. steel |
| B | Gasket spirometalic | spirometalic |
| C | Orifice plate | 1.4404 |
| D | Screw | Carbon steel or st. steel |
| E | Nuts | Carbon steel or st. steel |
| F | Extractor screw | Carbon steel or st. steel |
| G | Pressure Taps x 2 at 180° for flange | 1.4404 |
| H | Oval flange | 1.4401 |
| I | Nipple | 1.4404 |
| J | Plug | Carbon steel or st. steel |



Orifice Plate and Orifice Flange Model KPL

| D [inch] | Flanges according to ANSI B16.36 L [mm (inch)] (approx.) | | | | | Approx. Weight [kg (lbs)] | | | | |
|-------------|---|-----------------|-----------------|-----------------|-----------------|------------------------------|-------------------|--------------------|--------------------|--------------------|
| | Cl. 300 | Cl. 600 | Cl. 900 | Cl. 1500 | Cl. 2500 | Cl. 300 | Cl. 600 | Cl. 900 | Cl. 1500 | Cl. 2500 |
| 2" | 182.7 (7.2) | 182.7 (7.2) | 226.9 (8.9) | 226.9 (8.9) | 277.7 (10.9) | 18.1 (39.9) | 18.1 (39.9) | 35 (77) | 35 (77) | 59.6 (131.1) |
| 2½" | 188.8 (7.2) | 188.8 (7.2) | 233 (9.2) | 233 (9.2) | 309.2 (12.1) | 24.2 (53.2) | 24.2 (53.2) | 50 (110) | 50 (110) | 74.9 (164.9) |
| 3" | 188.8 (7.4) | 188.8 (7.4) | 226.9 (8.9) | 258.4 (10.2) | 360 (14.2) | 26.7 (58.6) | 28.5 (62.8) | 40.7 (89.6) | 67.2 (147.9) | 129.6 (285.2) |
| 4" | 194.9 (7.7) | 226.9 (8.9) | 252.3 (9.9) | 271.6 (10.7) | 404.7 (15.9) | 36.3 (79.9) | 51.3 (112.8) | 69.1 (152.1) | 99.6 (219.1) | 203.2 (447.1) |
| 5" | 214.2 (8.4) | 243.4 (9.6) | 277.8 (10.9) | 335 (13.2) | - | 41.1 (90.5) | 80.4 (176.8) | 110.5 (243) | 175.2 (385.3) | - |
| 6" | 211.2 (8.3) | 258.4 (10.2) | 303.1 (11.9) | 366.6 (14.4) | 569.8 (22.4) | 54.7 (120.4) | 104.7 (130.3) | 140.3 (308.7) | 187.6 (412.7) | 523 (1150.7) |
| 8" | 236.5 (9.3) | 293.4 (11.6) | 350.8 (13.8) | 452.4 (17.8) | 661.7 (26.1) | 83.2 (183.1) | 153.1 (336.8) | 229 (503.8) | 348.8 (767.3) | 802 (1764.5) |
| 10" | 248.7 (9.8) | 331.5 (13.1) | 395 (15.6) | 534.7 (21.1) | 864.9 (34.1) | 124.7 (274.3) | 245.1 (539.3) | 329.1 (723.9) | 592.9 (1304.4) | 1473 (3240.6) |
| 12" | 274.1 (10.8) | 337.6 (13.3) | 427 (16.8) | 591.6 (23.3) | 953.8 (37.6) | 183.4 (403.4) | 297.7 (654.9) | 414.1 (911) | 923.4 (2031.4) | 2206.9 (4855.1) |
| 14" | 299.8 (11.8) | 356.9 (14.1) | 452.4 (17.8) | 623.6 (24.6) | - | 235.7 (518.5) | 438 (963.5) | 450.2 (990.4) | 1071.1 (2356.5) | - |
| 16" | 310.2 (12.2) | 386.3 (15.2) | 462.5 (18.2) | 653 (25.7) | - | 331.7 (729.7) | 601.3 (1322.9) | 569.8 (1253.7) | 1437 (3161.3) | - |
| 18" | 355.6 (13.2) | 399 (15.7) | 487.9 (19.2) | 685 (27) | - | 419.9 (923.9) | 713.6 (1569.9) | 787.8 (1733.2) | 1863.8 (4100.4) | - |
| 20" | 342.1 (13.5) | 411.7 (16.2) | 526 (20.7) | 741.9 (29.2) | - | 499.3 (1098.4) | 886.1 (1949.4) | 967.4 (2128.2) | 2386.9 (5251.1) | - |
| 24" | 356.6 (14) | 439.1 (17.3) | 616.9 (24.3) | 845.5 (33.3) | - | 708.1 (1557.8) | 932.1 (2050.6) | 1733.5 (3813.7) | 3824.9 (8414.8) | - |



Technical Details

Nominal size: DN50...DN600 or 2" ...24"
 Max. Temperature:
 Compact version: +200 °C (liquids/gases)
 +300 °C (steam)
 Remote version: +500 °C
 Max. Pressure: PN420
 Sustained pressure loss: function of orifice ratio d/D
 approx. 20...70% of differential pressure head
 Orifice diameter 'd': is calculated using the operating data

Materials

Orifice plate: stainless steel 1.4404 (316L)
 other materials and coatings on request
 Flange: Carbon steel (A105)
 stainless steel 1.4404 (316L)
 Screws/Nuts/Taps: Carbon steel or
 Stainless steel (see table)
 Plate Roughness: Ra < 0.8 µm
 Installation position: concentric with pipe
 Marking: see descripton KPL-B

Materials and Temperature Limits

| Part | Material | Temperature Limit |
|-------------------------------------|--|--|
| Orifice Plate | St. steel 1.4404 (316L) | -198 °C...+538 °C (-325 °F... 1000 °F) |
| Flanges | Carbon Steel (A105) | -28 °C...+538 °C (-20 °F... 1000 °F) |
| Flanges | St. steel 1.4404 (316L) | -198 °C...+538 °C (-325 °F... 1000 °F) |
| Gasket Spiral Wound Type (standard) | Carbon steel flanges: Carbon Steel outer, Stainless Steel inner, 316L windings with graphite filler Stainless steel flanges: Stainless steel outer, Stainless steel inner, 316L windings with graphite filler | -210 °C...+538 °C (-350 °F... 1000 °F) |
| Gasket (optional) | Klinger Sil® | -73 °C...+371 °C (-100 °F... 700 °F) |
| Screws | Carbon steel flanges: Carbon Steel, A193 Grade B7M Stainless steel flanges:Stainless steel 316, A193 Grade B8M | - |
| Nuts | Carbon steel flanges: Carbon Steel, A194 Gr 2H Stainless steel flanges:Stainless steel 316, A194 Grade 8M | - |

* The temperature limits depend on the pressure and the medium.

Measuring ranges

The calculations for the orifice diameter and the different orifice shapes are part of the delivery scope, and are based on DIN EN ISO 5167-2 regulations. Calculations according to API (AGA-3) are available on request.

The Reynolds number, the roughness, and the temperature expansion of the plate and pipeline are used in the calculations for the orifice coefficient and the expansibility factor.

Extensive calculation programs are available for the orifice plate model shapes. A summary of the design data, including the expected pressure loss, are contained on a calculation sheet accompanying every plate supplied.

We require detailed technical data when designing the orifice plate and orifice flange. Kindly fill out the Application Data Sheet (ADS) at the end of this data sheet to inquire.

Design example (for water, 5 °C, d = 0.6xD, measuring range factor 5:1 and flange tapping of differential pressure)

| Nominal size | Flow rate [m³/h] | Differential pressure [mbar] | Sustained pressure loss [mbar] | Nominal size | Flow rate [m³/h] | Differential pressure [mbar] | Sustained pressure loss [mbar] |
|--------------|------------------|------------------------------|--------------------------------|--------------|------------------|------------------------------|--------------------------------|
| DN50 | 1-5 | 1.7-44.6 | 0.7-19.4 | DN300 | 80-400 | 9.0-226.7 | 3.9-99.7 |
| | 2-10 | 7.0-180.3 | 3.0-78.6 | | 100-500 | 14.0-354.4 | 6.1-155.9 |
| | 5-25 | 44.6-1134.3 | 19.4-496.2 | | 170-850 | 40.8-1025.3 | 17.9-451.3 |
| DN80 | 5-25 | 6.7-173.2 | 2.9-75.8 | DN350 | 100-500 | 7.8-191.3 | 3.3-84.1 |
| | 8-40 | 17.5-444.7 | 7.8-194.9 | | 150-750 | 17.1-430.8 | 7.5-189.6 |
| | 12-60 | 39.6-1002.5 | 17.2-439.6 | | 220-1100 | 36.9-927.2 | 16.2-408.2 |
| DN100 | 9-45 | 9.0-230.7 | 3.9-101.1 | DN400 | 150-750 | 10.0-252.5 | 4.4-111.1 |
| | 12-60 | 16.2-410.7 | 7.0-180.1 | | 200-1000 | 17.8-449.1 | 7.8-197.7 |
| | 18-90 | 36.6-925.6 | 16.0-406.3 | | 300-1500 | 40.3-1011.1 | 17.7-445.2 |
| DN150 | 20-100 | 8.9-225.8 | 3.8-99.1 | DN500 | 230-1150 | 9.6-243.3 | 4.2-107.1 |
| | 25-125 | 13.9-353.2 | 6.1-155.1 | | 300-1500 | 16.4-414.6 | 7.2-182.3 |
| | 40-200 | 35.9-905.5 | 16.0-406.3 | | 460-2300 | 38.8-974.2 | 17.0-429.0 |
| DN200 | 35-175 | 8.6-219.2 | 3.7-96.3 | DN600 | 300-1500 | 7.9-199.7 | 3.4-87.9 |
| | 50-250 | 17.7-447.9 | 7.7-7196.9 | | 400-2000 | 14.1-355.1 | 6.2-156.4 |
| | 70-350 | 34.9-878.7 | 15.3-386.4 | | 700-3500 | 43.4-1088.3 | 19.1-479.3 |
| DN250 | 50-250 | 7.2-183.4 | 3.1-80.6 | | | | |
| | 80-400 | 18.6-470.2 | 8.1-206.8 | | | | |
| | 120-600 | 42.1-1058.8 | 18.5-465.9 | | | | |

Mounting positions

| Medium | Mounting | Flow Pipe arrangement | Flow direction | Possible mounting position |
|---------|----------|-----------------------|--------------------|----------------------------|
| Liquids | Compact | Horizontal | from left | # L1* |
| | | | from right | # L2* |
| | | Vertical | up | # L3* |
| | | | down | # L4* |
| | Remote | Horizontal | from left or right | # L5* 0° taps |
| | | | | # L6* angle taps |
| | | Vertical | up or down | # L7* 0° taps |
| | | | | # L8* 90° taps |

* Ordering of optional multi-planar flange necessary

Mounting positions (continuation)

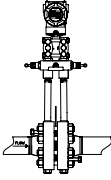
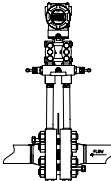
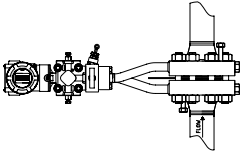
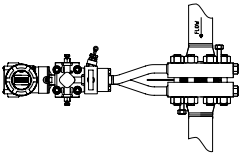
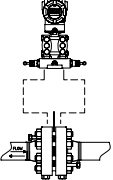
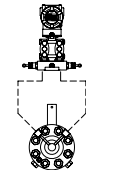
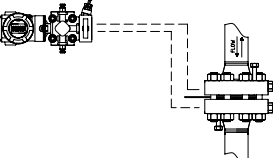
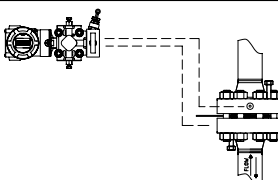
| Medium | Mounting | Flow Pipe arrangement | Flow direction | Possible mounting position |
|--------|----------|-----------------------|--------------------|---|
| Gas | Compact | Horizontal | from left | # G1*  |
| | | | from right | # G2*  |
| | | Vertical | up | # G3*  |
| | | | down | # G4*  |
| | Remote | Horizontal | from left or right | # G5* 0° taps  |
| | | | | # G6* angle taps  |
| | | Vertical | up or down | # G7* 0° taps  |
| | | | | # G8* 90° taps  |

* Ordering of optional multi-planar flange necessary

Mounting positions (continuation)

| Medium | Mounting | Flow Pipe arrangement | Flow direction | Possible mounting position | | |
|--------|----------|-----------------------|--|----------------------------|--------------------|--|
| Steam | Compact | Horizontal | from left or right PAD away from pipe | # S1 from left | # S2 from right | |
| | | | from left or right PAD towards pipe | # S3 from right | # S4 from left | |
| | | Vertical | up | # S5 | | |
| | | | down | # S6 | | |
| | | Remote | Horizontal | from left or right | # S7* 180° taps | |
| | | | | | # S8 0° taps | |
| | Vertical | | up or down | # S9 0° taps | | |
| | | | | # S0* 90° taps | | |

* Ordering of optional multi-planar flange necessary

Mounting positions

Liquids

Position L1

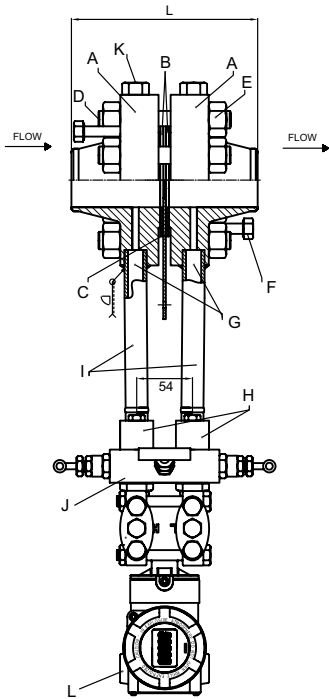

Position L2

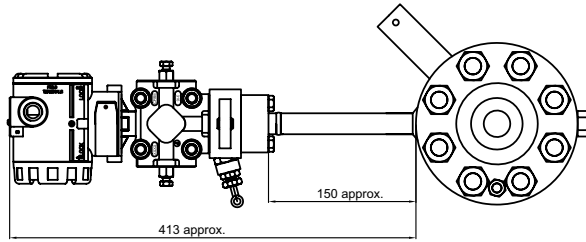
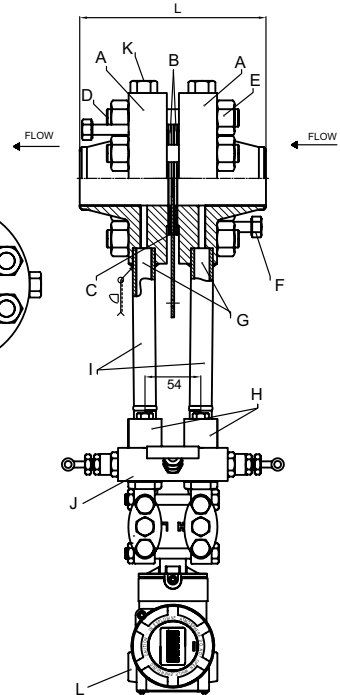

| Pos. | Description |
|------|---------------------------------------|
| A | Flange |
| B | Gaskets |
| C | Orifice Plate |
| D | Screw |
| E | Nuts |
| F | Extractor screw |
| G | Pressure taps x 2 ... 180° for flange |
| H | Oval flange for connection manifold |
| I | Nipples |
| J | Manifold, machined |
| K | Plugs |
| L | Differential pressure transmitter PAD |

Position L3

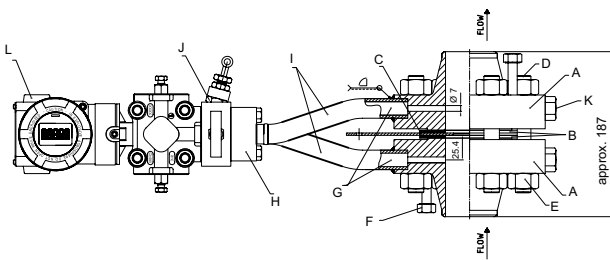

Position L4

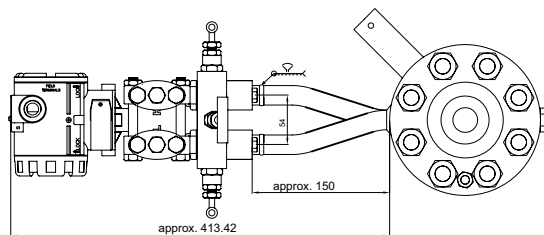
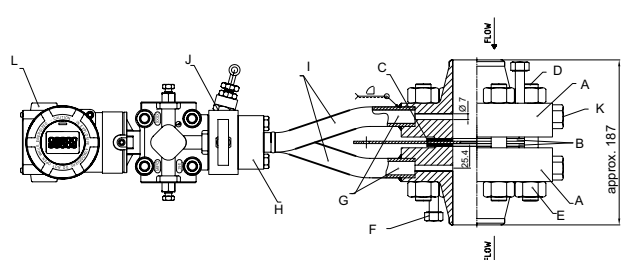

Mounting positions (continuation)

Liquids

Position L5

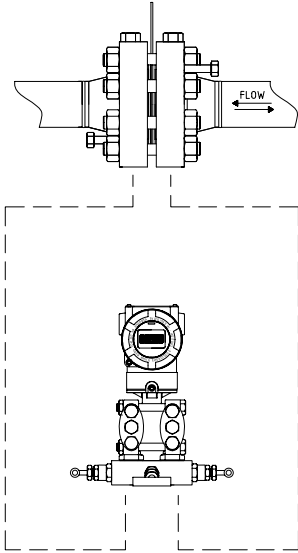

Position L6

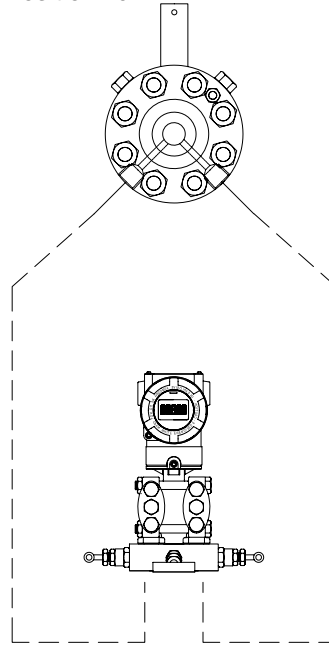

Position L7

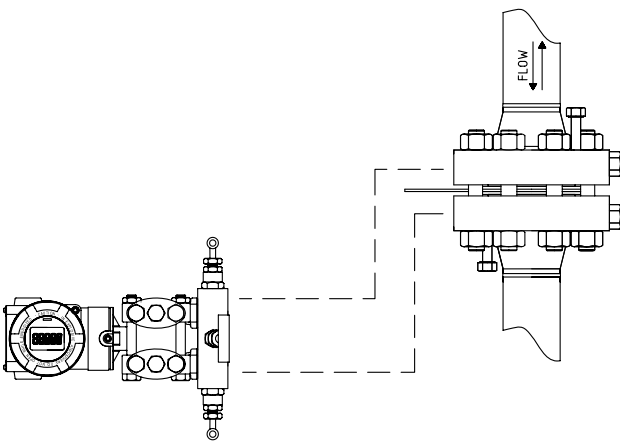

Position L8

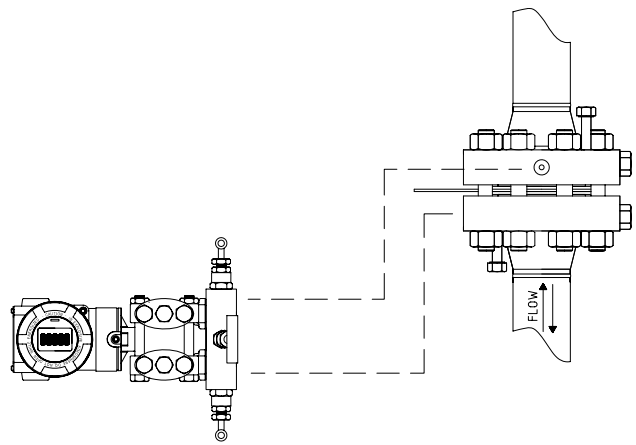

Mounting positions (continuation)

Position G1

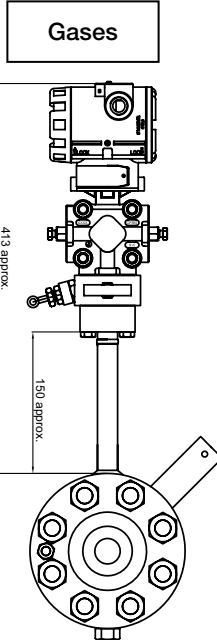
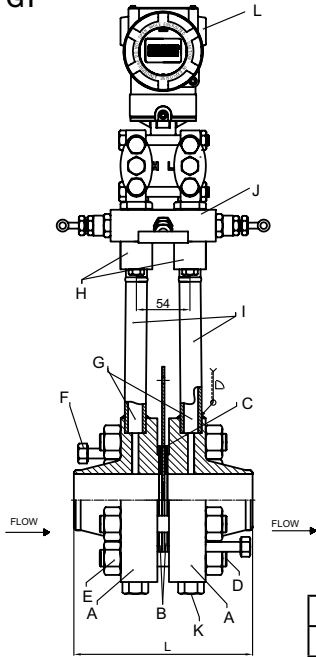

Position G2

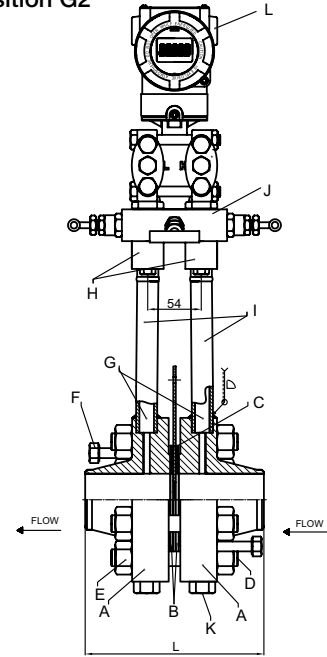

| Pos. | Description |
|------|---------------------------------------|
| A | Flange |
| B | Gaskets |
| C | Orifice Plate |
| D | Screw |
| E | Nuts |
| F | Extractor screw |
| G | Pressure taps x 2 ... 180° for flange |
| H | Oval flange for connection manifold |
| I | Nipples |
| J | Manifold, machined |
| K | Plugs |
| L | Differential pressure transmitter PAD |

Position G3

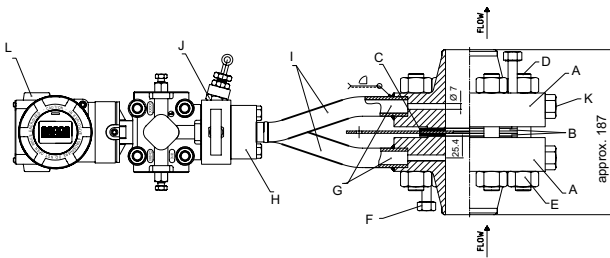

Position G4

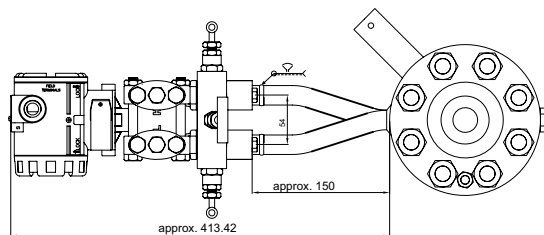
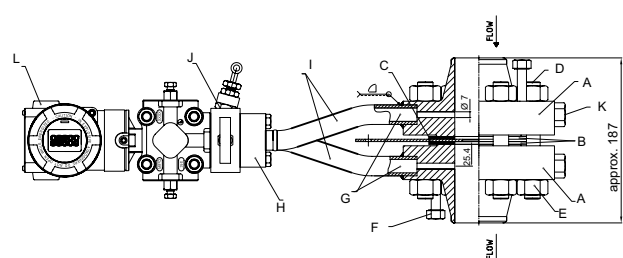

Mounting positions (continuation)

Gases

Position G5

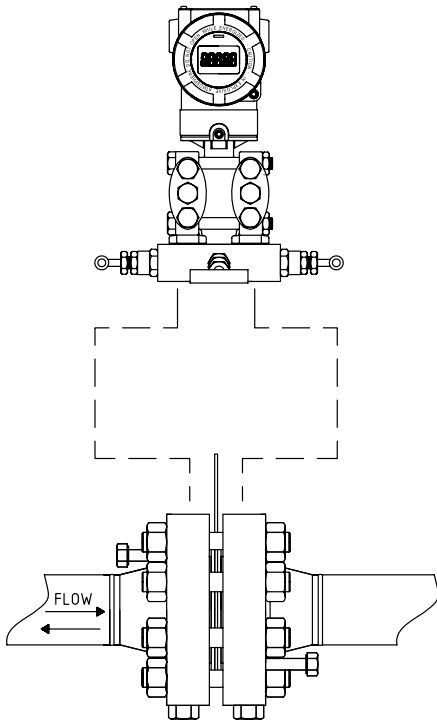

Position G6

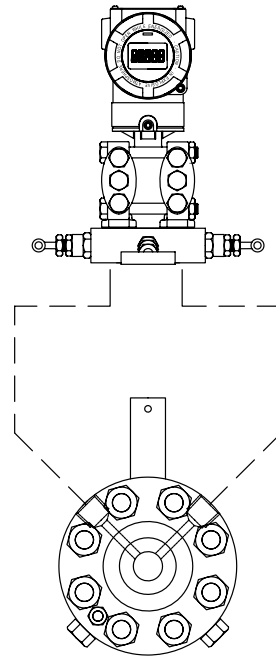

Position G7

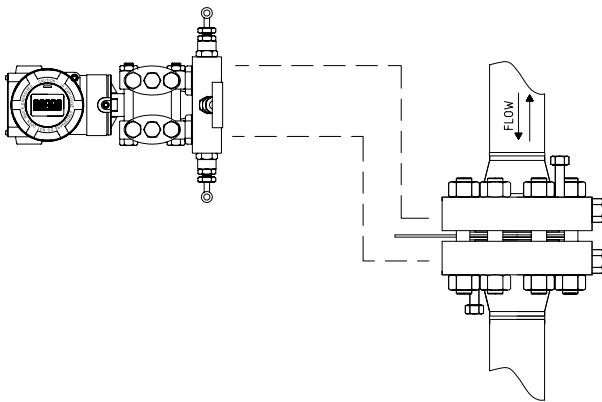

Position G8

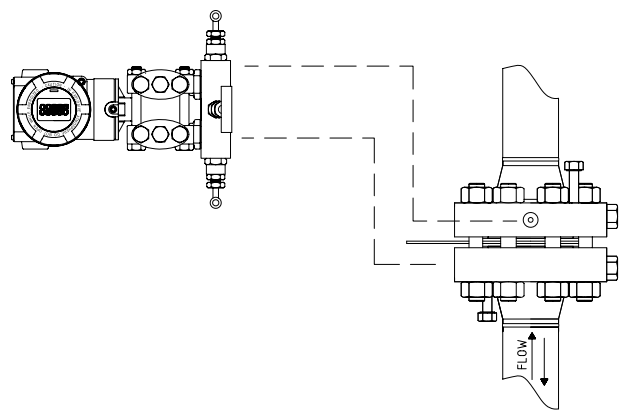

Mounting positions (continuation)

Steam

Position S1

Side View

Top View

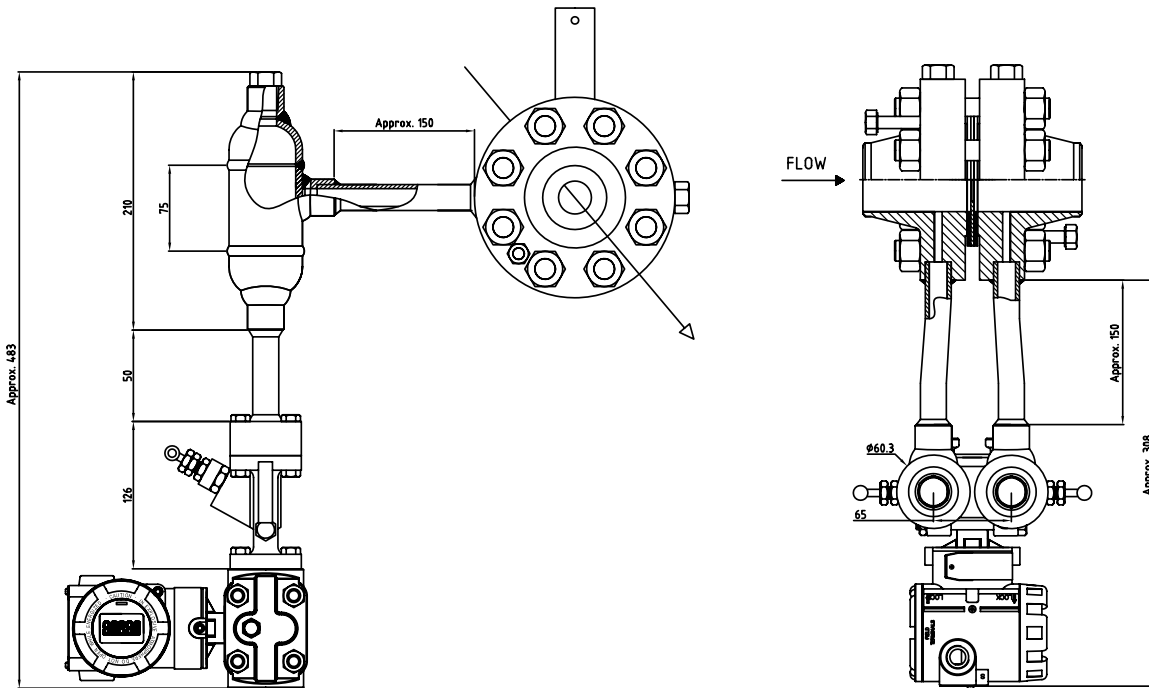

Position S2

Side View

Top View

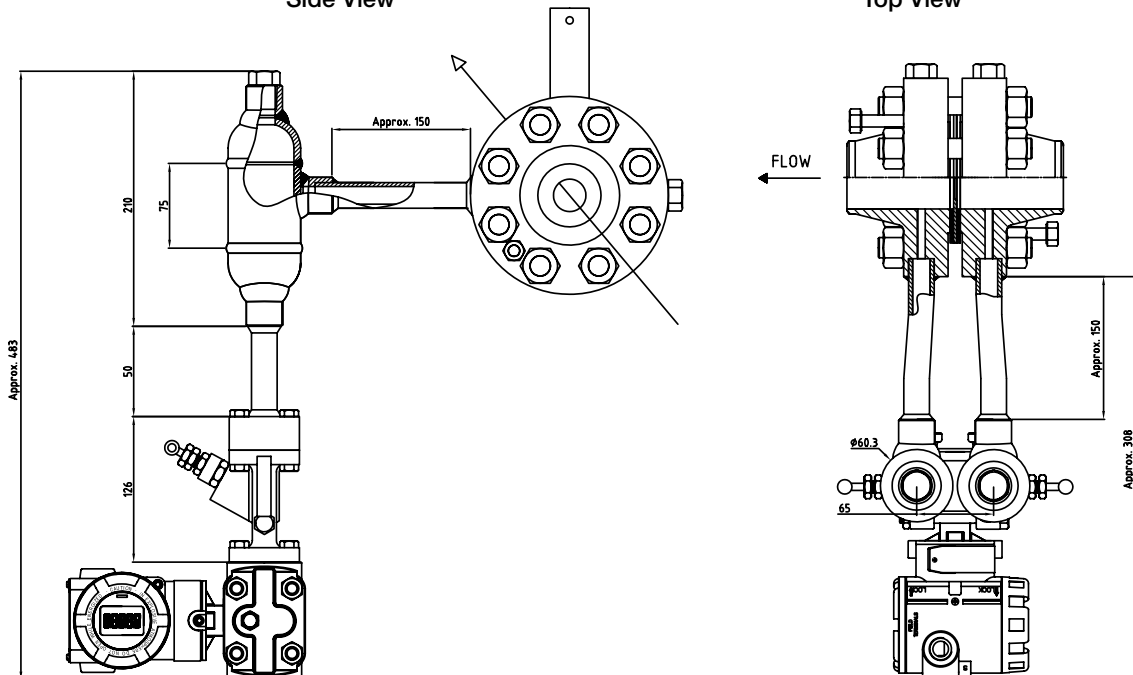

Mounting positions (continuation)

Steam

Position S3

Side View

Top View

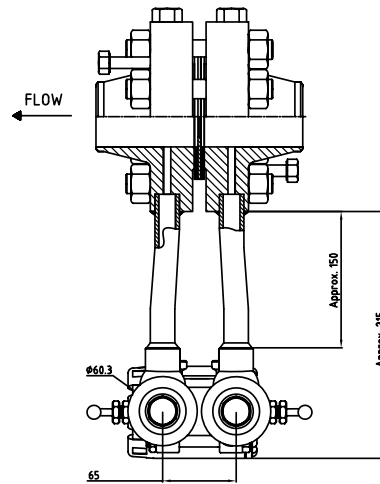
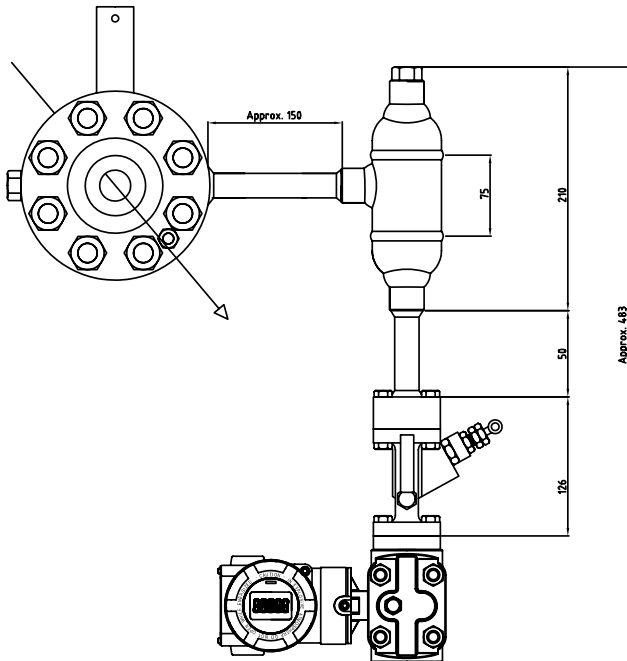

Position S4

Side View

Top View

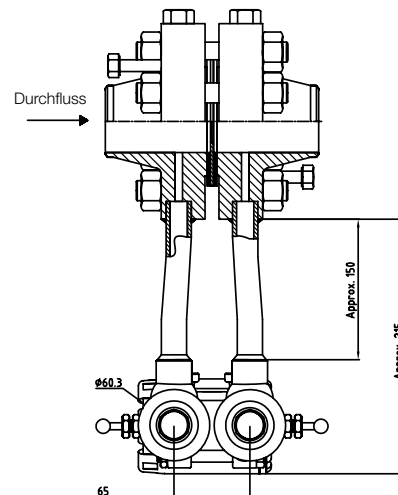
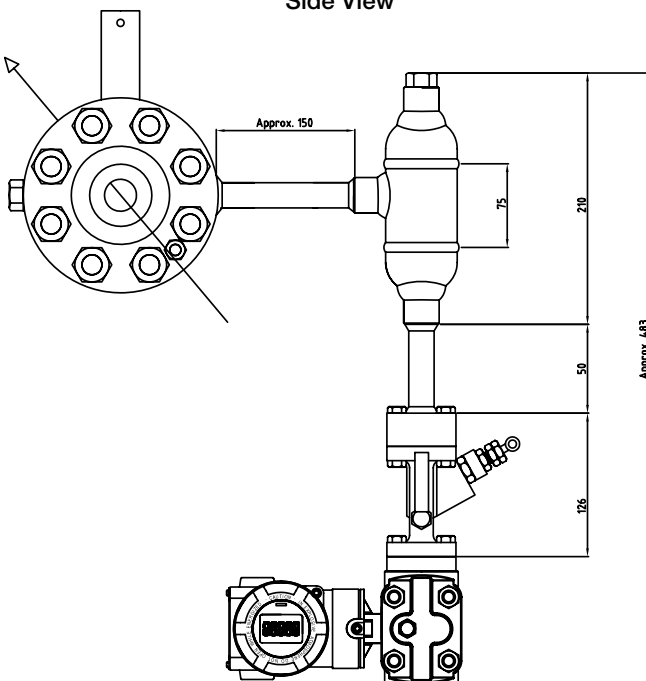

Mounting positions (continuation)

Position S5
Front View

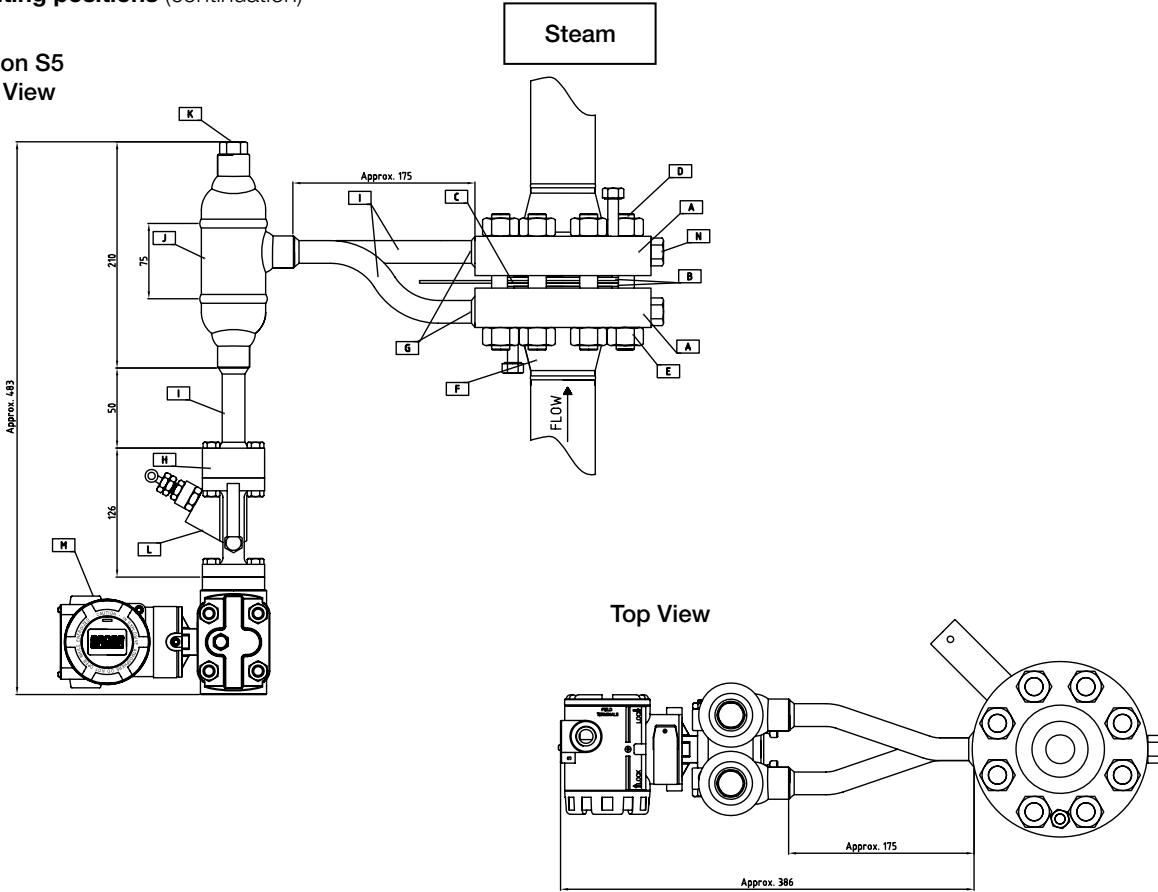

Position S6
Front View

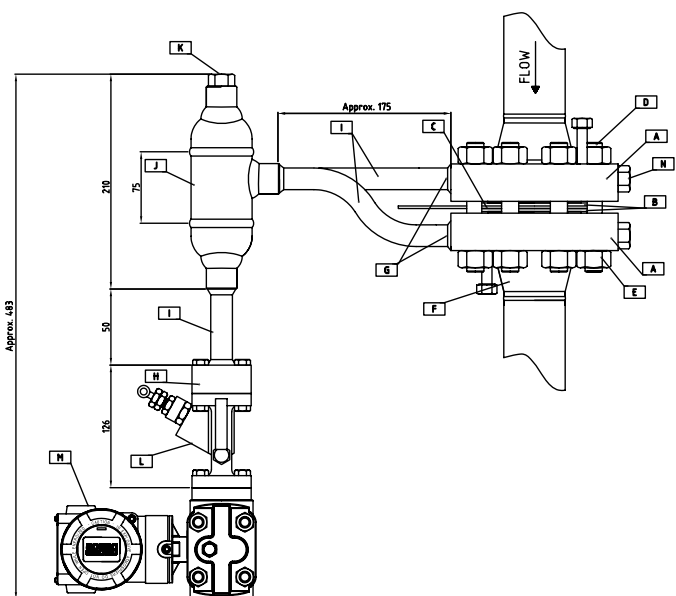

| Pos. | Description |
|------|---------------------------------------|
| A | Flange |
| B | Gaskets |
| C | Orifice Plate |
| D | Screw |
| E | Nuts |
| F | Extractor screw |
| G | Pressure taps x 2 ... 180° for flange |
| H | Oval flange for connection manifold |
| I | Nipples |
| J | Condensate pot |
| K | Taps |
| L | Manifold, forged |
| M | Differential pressure transmitter PAD |
| N | Taps |

Mounting positions (continuation)

Steam

Position S7

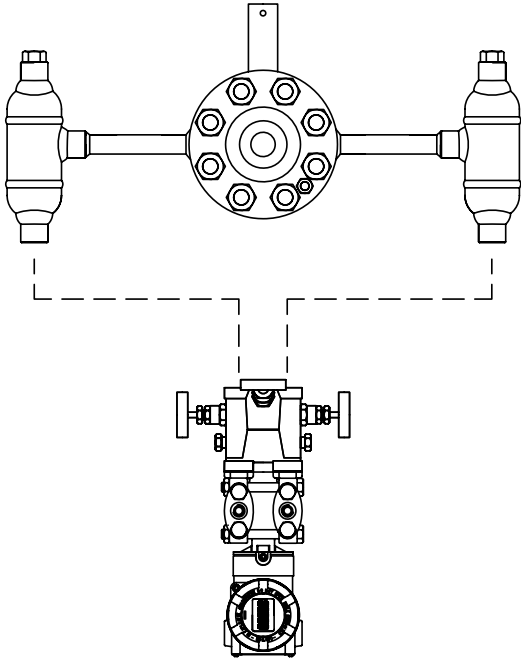

Position S8

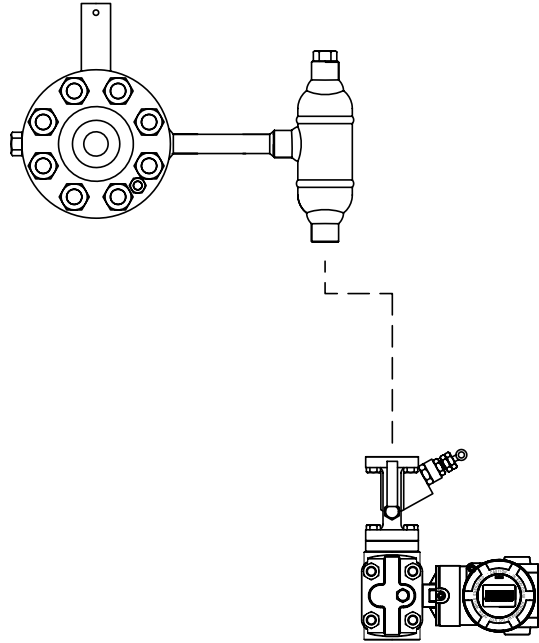

Position S9

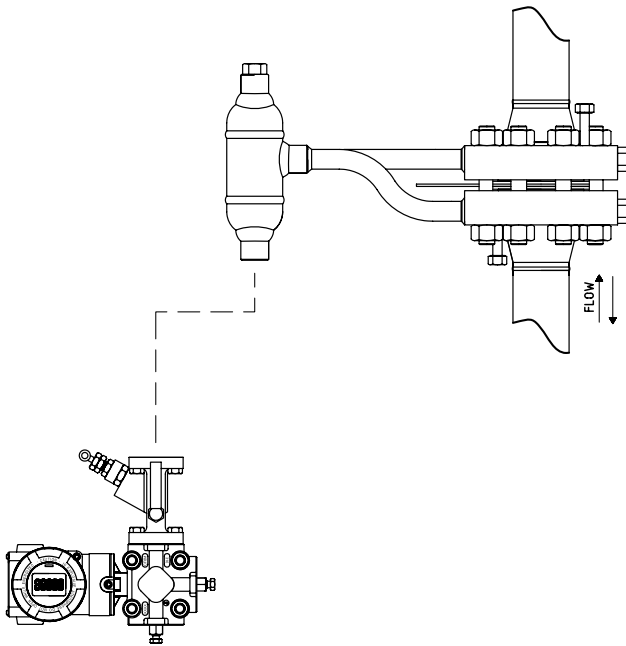

Position S0

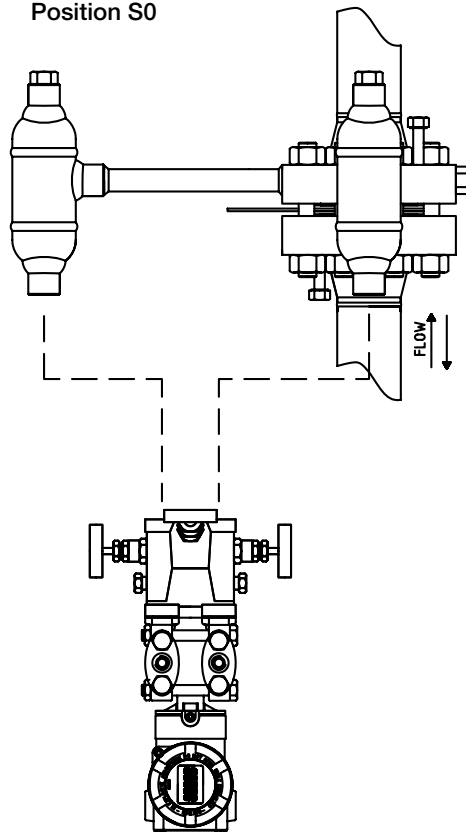



Dimensions in inches

(Weld Neck flange, slip-on and Threaded Orifice Flanges¹⁾²⁾ according to ASME B16.36-1996 Class 300)

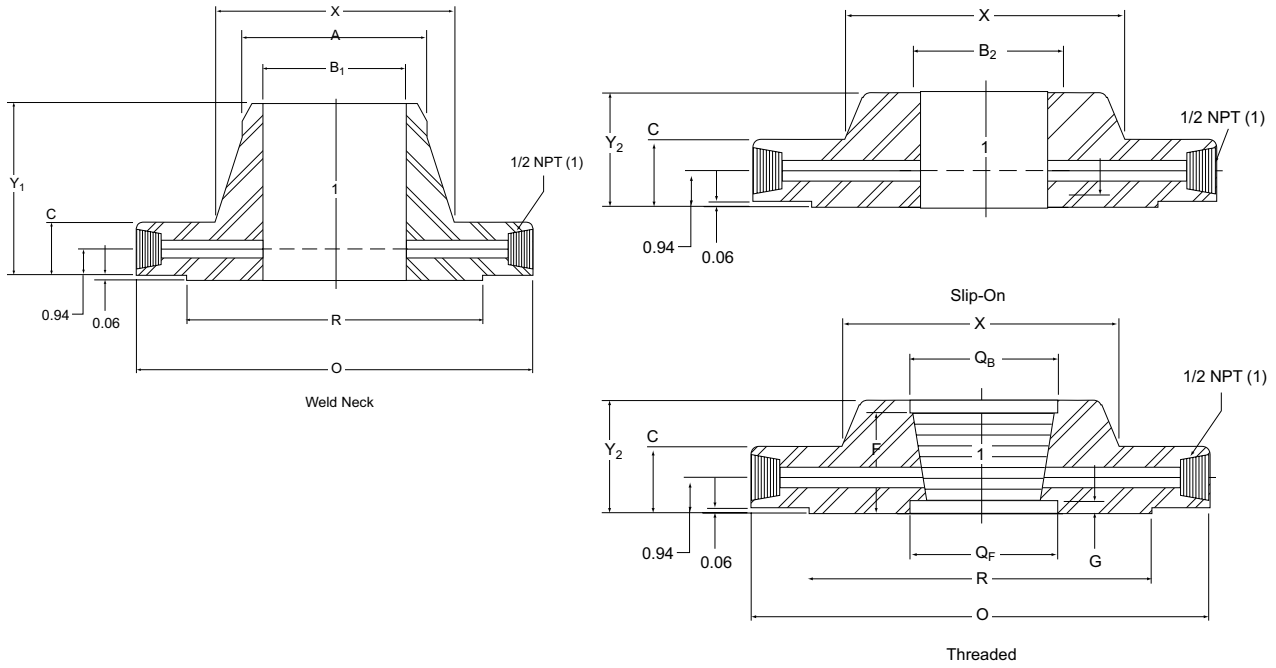

| Nominal Pipe Size [inch] | Outside Ø of raised face R | Outside Ø of flange O | Thickness of flange, min. C | Length through Hub | | Ø of Hub X | Hub Ø beginning of Chamfer (W.N.) A | Ø of counterbore | | Counterbore depth (from face) | | Bore | |
|--------------------------|----------------------------|-----------------------|-----------------------------|-------------------------------------|--------------------------|------------|-------------------------------------|--|---------------------|-------------------------------|------|------------------------|--|
| | | | | Slip-On and threaded Y ₂ | Weld Neck Y ₁ | | | Back Q _B | Face Q _F | F | G | Slip-On B ₂ | Weld Neck B ₁ |
| 1 | 2.00 | 4.88 | 1.50 | 1.88 | 3.25 | 2.12 | 1.32 | 1.41 | 1.30 | 1.44 | 0.75 | 1.36 | Threaded flanges are furnished in NPS 1-8 only |
| 1½ | 2.88 | 6.12 | 1.50 | 1.88 | 3.38 | 2.75 | 1.90 | 1.99 | 1.89 | 1.47 | 0.72 | 1.95 | |
| 2 | 3.62 | 6.50 | 1.50 | 1.94 | 3.38 | 3.31 | 2.38 | 2.50 | 2.36 | 1.50 | 0.69 | 2.44 | |
| 2½ | 4.12 | 7.50 | 1.50 | 2.00 | 3.50 | 3.94 | 2.88 | 3.00 | 2.84 | 1.75 | 0.56 | 2.94 | |
| 3 | 5.00 | 8.25 | 1.50 | 2.06 | 3.50 | 4.62 | 3.50 | 3.63 | 3.46 | 1.81 | 0.56 | 3.57 | |
| 4 | 6.19 | 10.00 | 1.50 | 2.12 | 3.62 | 5.75 | 4.50 | 4.63 | 4.45 | 1.88 | 0.56 | 4.57 | |
| 6 | 8.50 | 12.50 | 1.50 | 2.12 | 3.94 | 8.12 | 6.63 | 6.75 | 6.57 | 1.88 | 0.31 | 6.72 | |
| 8 | 10.62 | 15.00 | 1.62 | 2.44 | 4.38 | 10.25 | 8.63 | 8.75 | 8.55 | 2.19 | 0.44 | 8.72 | |
| 10 | 12.75 | 17.50 | 1.88 | 2.62 | 4.62 | 12.62 | 10.75 | Bore diameter of weld neck flanges is to be specified by the purchaser | | | | 10.88 | |
| 12 | 15.00 | 20.50 | 2.00 | 2.88 | 5.12 | 14.75 | 12.75 | | | | | 12.88 | |
| 14 | 16.25 | 23.00 | 2.12 | 3.00 | 5.62 | 16.75 | 14.00 | | | | | 14.14 | |
| 16 | 18.50 | 25.50 | 2.25 | 3.25 | 5.75 | 19.00 | 16.00 | | | | | 16.16 | |
| 18 | 21.00 | 28.00 | 2.38 | 3.50 | 6.25 | 21.00 | 18.00 | | | | | 18.18 | |
| 20 | 23.00 | 30.50 | 2.50 | 3.75 | 6.38 | 23.12 | 20.00 | | | | | 20.20 | |
| 24 | 27.25 | 36.00 | 2.75 | 4.19 | 6.62 | 27.62 | 24.00 | | | | | 24.25 | |



Orifice Plate and Orifice Flange Model KPL

| Nominal Pipe Size [inch] ¹⁾²⁾ | Ø of Pressure Connection TT | Drilling Template | | | | Bolt Length ³⁾⁴⁾ | |
|--|-----------------------------|-------------------|-----------------|------------|------------|-----------------------------|------------|
| | | Bolt Circle | Number of Holes | Ø of Holes | Ø of Bolts | Machine Bolts | Stud Bolts |
| 1 | ¼ | 3.50 | 4 | 0.69 | ⅝ | 4.50 | 5.00 |
| 1 ½ | ¼ | 4.50 | 4 | 0.81 | ¾ | 4.75 | 5.25 |
| 2 | ¼ | 5.00 | 8 | 0.69 | ¾ | 4.50 | 5.00 |
| 2 ½ | ¼ | 5.88 | 8 | 0.81 | ¾ | 4.75 | 5.25 |
| 3 | ⅝ | 6.62 | 8 | 0.81 | ¾ | 4.75 | 5.25 |
| 4 | ½ | 7.88 | 8 | 0.81 | ¾ | 4.75 | 5.25 |
| 6 | ½ | 10.62 | 12 | 0.88 | ¾ | 4.75 | 5.25 |
| 8 | ½ | 13.00 | 12 | 1.00 | ⅞ | 5.00 | 5.75 |
| 10 | ½ | 15.25 | 16 | 1.12 | 1 | 5.75 | 6.50 |
| 12 | ½ | 17.75 | 16 | 1.25 | 1 ⅛ | 6.25 | 7.00 |
| 14 | ½ | 20.25 | 20 | 1.25 | 1 ⅛ | 6.50 | 7.25 |
| 16 | ½ | 22.50 | 20 | 1.38 | 1 ¼ | 7.00 | 7.75 |
| 18 | ½ | 24.75 | 24 | 1.38 | 1 ¼ | 7.25 | 8.00 |
| 20 | ½ | 27.00 | 24 | 1.38 | 1 ¼ | 7.50 | 8.50 |
| 24 | ½ | 32.00 | 24 | 1.62 | 1 ½ | 8.25 | 9.50 |

¹⁾ Weld neck flanges NPS 3 and smaller are identical to Class 600 flanges and may be so marked.

²⁾ All other dimensions are in accordance with ASME B16.5.

³⁾ Bolt lengths include allowance for orifice and gasket thickness of 0.25 inch for NPS 1 ... 12 and 0.38 inch for NPS 14 ... 24.

⁴⁾ In conformance with ASME B16.5, stud bolt lengths do not include point heights.



Dimensions in inches
(Weld Neck Orifice Flanges¹⁾²⁾ according to ASME B16.36-1996 Class 600)

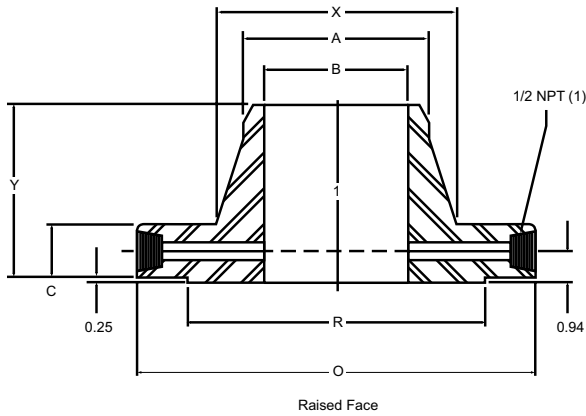

Raised Face

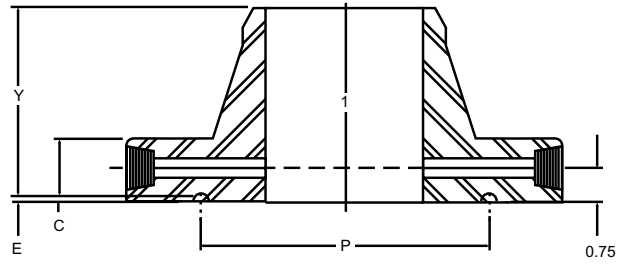

Ring Type Joint

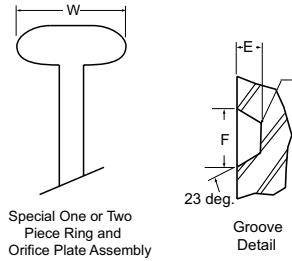

Special One or Two Piece Ring and Orifice Plate Assembly

Groove Detail

| Nominal Pipe Size [inch] | Outside Ø of raised face R | Outside Ø of flange O | Thickness of flange, min. C | Length through Hub Y | Height of Raised Face H | Ring Type Joint | | | | | Special Oval Ring Height W | Ø of Hub X | Hub Ø Beginning of Chamfer A |
|--------------------------|----------------------------|-----------------------|-----------------------------|----------------------|-------------------------|-----------------|------------------|----------------|----------------|-----------------------------------|----------------------------|------------|------------------------------|
| | | | | | | Groove Number | Pitch Diameter P | Groove Depth E | Groove Width F | Radius at Bottom r _{max} | | | |
| 1 | 2.00 | 4.88 | 1.44 | 3.19 | 0.06 | R16 | 2.000 | 0.250 | 0.344 | 0.03 | 1.00 | 2.12 | 1.32 |
| 1½ | 2.88 | 6.12 | 1.44 | 3.32 | 0.06 | R20 | 2.688 | 0.688 | 0.344 | 0.03 | 1.00 | 2.75 | 1.90 |
| 2 | 3.62 | 6.50 | 1.44 | 3.32 | 0.06 | R23 | 3.250 | 0.312 | 0.469 | 0.03 | 1.06 | 3.31 | 2.38 |
| 2½ | 4.12 | 7.50 | 1.44 | 3.44 | 0.06 | R26 | 4.000 | 0.312 | 0.469 | 0.03 | 1.06 | 3.94 | 2.88 |
| 3 | 5.00 | 8.25 | 1.44 | 3.44 | 0.06 | R31 | 4.875 | 0.312 | 0.469 | 0.03 | 1.06 | 4.62 | 3.50 |
| 4 | 6.19 | 10.75 | 1.50 | 4.00 | 0.25 | R37 | 5.875 | 0.312 | 0.469 | 0.03 | 1.06 | 6.00 | 4.50 |
| 6 | 8.50 | 14.00 | 1.88 | 4.62 | 0.25 | R45 | 8.312 | 0.312 | 0.469 | 0.03 | 1.06 | 8.75 | 6.63 |
| 8 | 10.62 | 16.50 | 2.19 | 5.25 | 0.25 | R49 | 10.625 | 0.312 | 0.469 | 0.03 | 1.06 | 10.75 | 8.63 |
| 10 | 12.75 | 20.00 | 2.50 | 6.00 | 0.25 | R53 | 12.750 | 0.312 | 0.469 | 0.03 | 1.06 | 13.50 | 10.75 |
| 12 | 15.00 | 22.00 | 2.62 | 6.12 | 0.25 | R57 | 15.000 | 0.312 | 0.469 | 0.03 | 1.06 | 15.75 | 12.75 |
| 14 | 16.25 | 23.75 | 2.75 | 6.50 | 0.25 | R61 | 16.500 | 0.312 | 0.469 | 0.03 | 1.06 | 17.00 | 14.00 |
| 16 | 18.50 | 27.00 | 3.00 | 7.00 | 0.25 | R65 | 18.500 | 0.312 | 0.469 | 0.03 | 1.19 | 19.50 | 16.00 |
| 18 | 21.00 | 29.25 | 3.25 | 7.25 | 0.25 | R69 | 21.000 | 0.312 | 0.469 | 0.03 | 1.19 | 21.50 | 18.00 |
| 20 | 23.00 | 32.00 | 3.50 | 7.50 | 0.25 | R73 | 23.000 | 0.375 | 0.531 | 0.06 | 1.25 | 24.00 | 20.00 |
| 24 | 27.25 | 37.00 | 4.00 | 8.00 | 0.25 | R77 | 27.250 | 0.438 | 0.656 | 0.06 | 1.44 | 28.25 | 24.00 |



| Nominal Pipe Size [inch] ¹⁾²⁾ | Diameter of Pressure Connection TT | Drilling Template | | | | Bolt Length ³⁾⁴⁾ | |
|--|------------------------------------|-------------------|-----------------|------------|------------|-----------------------------|------------|
| | | Bolt Circle | Number of Holes | Ø of Holes | Ø of Bolts | Machine Bolts | Stud Bolts |
| 1 | ¼ | 3.50 | 4 | 0.69 | 5/8 | 4.50 | 5.00 |
| 1 ½ | ¼ | 4.50 | 4 | 0.81 | ¾ | 4.75 | 5.25 |
| 2 | ¼ | 5.00 | 8 | 0.69 | ¾ | 4.50 | 5.00 |
| 2 ½ | ¼ | 5.88 | 8 | 0.81 | ¾ | 4.75 | 5.25 |
| 3 | ⅙ | 6.62 | 8 | 0.81 | ¾ | 4.75 | 5.25 |
| 4 | ½ | 7.88 | 8 | 0.81 | ¾ | 4.75 | 5.25 |
| 6 | ½ | 10.62 | 12 | 0.88 | ¾ | 4.75 | 5.25 |
| 8 | ½ | 13.00 | 12 | 1.00 | 7/8 | 5.00 | 5.75 |
| 10 | ½ | 15.25 | 16 | 1.12 | 1 | 5.75 | 6.50 |
| 12 | ½ | 17.75 | 16 | 1.25 | 1 ⅙ | 6.25 | 7.00 |
| 14 | ½ | 20.25 | 20 | 1.25 | 1 ⅙ | 6.50 | 7.25 |
| 16 | ½ | 22.50 | 20 | 1.38 | 1 ¼ | 7.00 | 7.75 |
| 18 | ½ | 24.75 | 24 | 1.38 | 1 ¼ | 7.25 | 8.00 |
| 20 | ½ | 27.00 | 24 | 1.38 | 1 ¼ | 7.50 | 8.50 |
| 24 | ½ | 32.00 | 24 | 1.62 | 1 ½ | 8.25 | 9.50 |

¹⁾ Weld neck flanges NPS 3 and smaller are identical to Class 600 flanges and may be so marked.

²⁾ All other dimensions are in accordance with ASME B16.5.

³⁾ Bolt lengths include allowance for orifice and gasket thickness of 0.25 inch for NPS 1 ... 12 and 0.38 inch for NPS 14 ... 24.

⁴⁾ In conformance with ASME B16.5, stud bolt lengths do not include point heights.

Note:

Dimensions of Weld Neck Orifice Flanges according to ASME B16.36-1996 Class 900, Class 1500 and Class 2500 on request.

Dimensions of Pipe Inner Diameter (Info.)

| Nominal Pipe size [inch] | Schedule (Standard) [inch] |
|--------------------------|----------------------------|
| 2 | 2.067 |
| 2 ½ | 2.469 |
| 3 | 3.068 |
| 4 | 4.026 |
| 6 | 6.065 |
| 8 | 7.981 |
| 10 | 10.20 |
| 12 | 12.00 |
| 14 | 13.250 |
| 16 | 15.250 |
| 18 | 17.250 |
| 20 | 19.252 |
| 24 | 23.250 |



Order Details Orifice Plate (Example: **KPL-B C 50 1 E FN 00**)
 (Application Data Sheet should be filled out while ordering)



| Model | Type | Bore Type | Line Size ²⁾ | Flange Rating ¹⁾²⁾ |
|-------|-------------------|--|---|---|
| KPL- | B = Orifice plate | C = Concentric (Standard) K = Conical Entrance Q = Quarter Circle Nozzle S = Segmental B = Bidirectional | 50 = DN 50 (2") 65 = DN 65 (2 1/2") 80 = DN 80 (3") 1H = DN 100 (4") 1F = DN 150 (6") 2H = DN 200 (8") 2F = DN 250 (10") 3H = DN 300 (12") 3F = DN 350 (14") 4H = DN 400 (16") 4F = DN 450 (18") 5H = DN 500 (20") 6H = DN 600 (24") XX = special version, to be specified | A = ANSI Class 300 RF B = ANSI Class 600 RF C = ANSI Class 900 RF D = ANSI Class 1500 RF E = ANSI Class 2500 RF F = ANSI Class 300 RTJ G = ANSI Class 600 RTJ H = ANSI Class 900 RTJ I = ANSI Class 1500 RTJ K = ANSI Class 2500 RTJ 1 = DN PN16 2 = DN PN25 3 = DN PN40 4 = DN PN63 5 = DN PN100 Y = special version, to be specified |

| Orifice Material | Pressure Tapping Drain / Vent Hole | Options |
|--|---|---|
| E = stainless steel 1.4404 (316L) Y = other material, to be specified | Information regarding tapping needed for orifice plate calculation FN = Orifice flange tapping FD = Orifice flange tapping, drain hole FV = Orifice flange tapping, vent hole CN = Orifice corner tapping CD = Orifice corner tapping, drain hole CV = Orifice corner tapping, vent hole DN = Orifice tapping D+D/2 DD = Orifice tapping D+D/2, drain hole DV = Orifice tapping D+D/2, vent hole YY = special version, to be specified | 00 = without Optional Certificates CF = Oil and fat free CO = Cleaning for oxygen SF = Silicone free MC = Material Certificate 3.1 according to EN 10204 NC = Material according to NACE MR-0175/ISO 15156 DG = Dimensional drawing YY = special option, to be specified |

¹⁾ Specify inner pipe diameter or alternatively nominal pipe size and pipe schedule

²⁾ Flange according to DIN EN 1092-1 and ANSI B 16.36

Note: Orifice plate calculation according to DIN EN ISO 5167-2 is standard.
 Orifice plate calculation according to API (AGA-3) available on request.



Orifice Plate and Orifice Flange Model KPL

Order Details Orifice Flange with /without Orifice Plate (Example: **KPL-F C 50 1 C FN C 00**)
 (Application Data Sheet should be filled out while ordering)



| Model ¹⁾ | Type | Bore Type | Line Size ²⁾ | Flange Rating ²⁾³⁾ | Flange material ⁴⁾ |
|---------------------|---|---|--|---|---|
| KPL- | N = Orifice flange Union (Weld neck flange) without orifice plate | N = not applicable (no orifice plate) | 50 = DN50 (2") 65 = DN65 (2 1/2") 80 = DN80 (3") 1H = DN100 (4") 1F = DN150 (6") 2H = DN200 (8") | A = ANSI Class 300 RF B = ANSI Class 600 RF C = ANSI Class 900 RF D = ANSI Class 1500 RF E = ANSI Class 2500 RF F = ANSI Class 300 RTJ G = ANSI Class 600 RTJ H = ANSI Class 900 RTJ I = ANSI Class 1500 RTJ K = ANSI Class 2500 RTJ | C = carbon steel (A105) E = stainless steel (316L) |
| | F = Orifice flange Union (Weld neck flange) with orifice plate Y = Others (Slip-on flange or threaded orifice flange on request, to be specified in clear text) | Orifice Plates C = Concentric (Standard) K = Conical Entrance Q = Quarter Circle Nozzle S = Segmental B = Bidirectional | 2F = DN250 (10") 3H = DN300 (12") 3F = DN350 (14") 4H = DN400 (16") 4F = DN450 (18") 5H = DN500 (20") 6H = DN600 (24") | 1 = DN PN16 2 = DN PN25 3 = DN PN40 4 = DN PN63 5 = DN PN100 Y = special version, to be specified | Y = special version, to be specified |

| Pressure Tapping Drain / Vent Hole | Version ⁵⁾ / Taps | Options |
|--|--|---|
| FN = Flange tapping FD = Flange tapping, drain hole FV = Flange tapping, vent hole CN = Corner tapping CD = Corner tapping, drain hole CV = Corner tapping, vent hole DN = Orifice tapping D+D/2 DD = Orifice tapping D+D/2, drain hole DV = Orifice tapping D+D/2, vent hole YY = special version, to be specified | C ⁶⁾ = Compact version / 0° and 180° taps (2x flange) 1/2" NPT female (standard) K ⁶⁾ = Compact version / 0° and 180° taps (2x flange) socket weld 1/2" (21.3 mm) R = Remote version / 0° and 180° taps (2x flange) 1/2" NPT female (standard) F = Remote version / 0° and 180° taps (2x flange) socket weld 1/2" (21.3 mm) Y = special version, to be specified | 00 = without Optional Certificates CF = Oil and fat free CO = Cleaning for oxygen SF = Silicone free MC = Material Certificate 3.1 according to EN 10204 NC = Material according to NACE MR-0175/ISO 15156 DG = Dimensional drawing YY = special option, to be specified |

¹⁾ Material orifice plate stainless steel 1.4404, others on request
²⁾ Flange according to DIN EN 1092-1 and ANSI B 16.36, raised face, weld neck as standard
³⁾ **Specify inner pipe diameter or alternatively nominal pipe size and pipe schedule**
⁴⁾ Bolts material is same as flange material
⁵⁾ Please consider applicable mounting positions as per your application, and specify the code (see sketch codes on previous pages under caption "Mounting positions").
⁶⁾ Compact versions are delivered with the primary element (KPL) mounted together with DP Transmitter, manifold and condensate chambers (when applicable). Please use separate model codes (available at the end of this data sheet) to order these accessories **in addition** to model KPL.

● **Accessories**

Flow straightener

A flow straightener is a device which removes or significantly reduces swirl but may not simultaneously produce the acceptable flow conditions. The 19-tube bundle flow straightener according to DIN EN ISO 5167-2 consists of 19 tubes (marked as "B", see related figure) arranged in a cylindrical pattern.

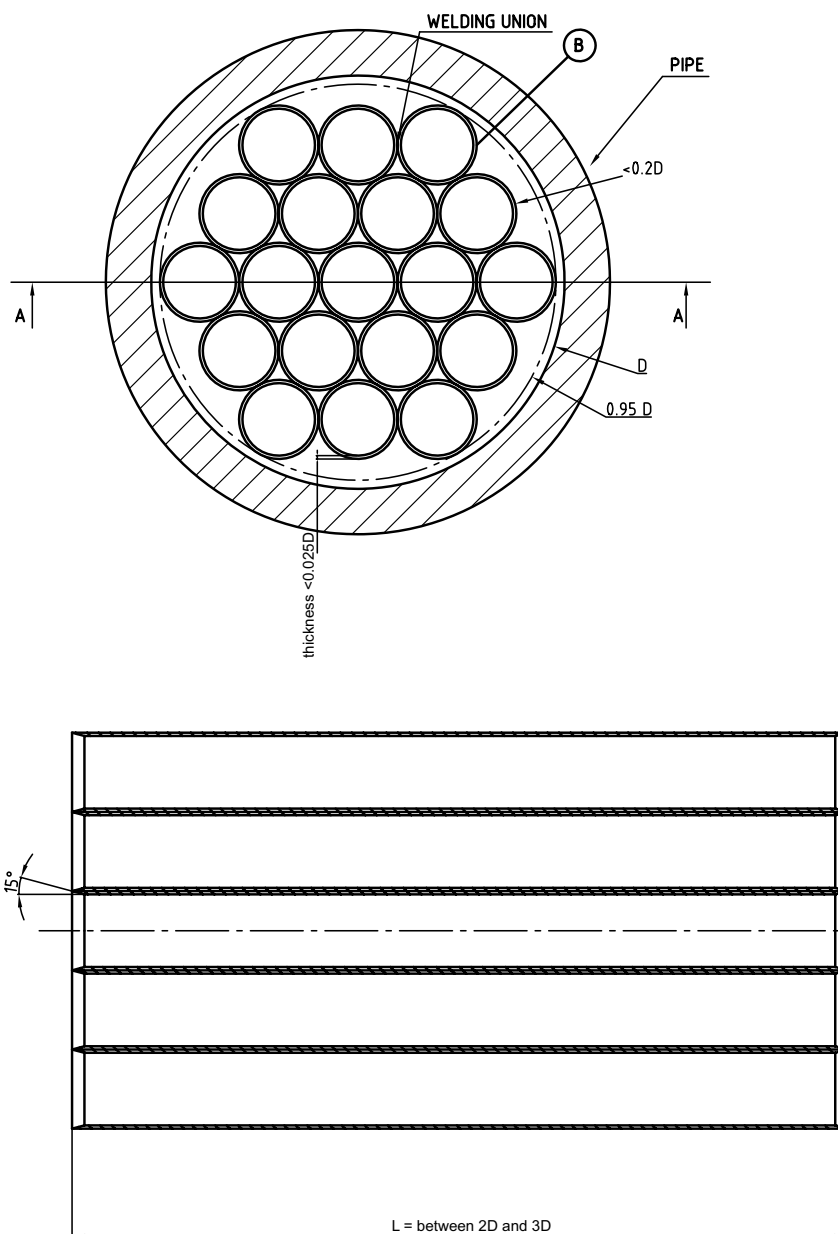

Flow conditioner

A flow conditioner is a device which, in addition to meeting the requirements of removing or significantly reducing swirl, is designed to redistributing the velocity profile to produce acceptable flow conditions. The flow conditioner can be used to reduce upstream straight lengths. The ZANKER flow conditioner according to DIN EN ISO 5167-2 plate can be used for $\beta \leq 0.67$ and consists of 32 bored holes arranged in asymmetrical circular pattern.

The approx. dimensions of the holes are a function of the pipe inside diameter 'D' and shall be as follows:

- a) a ring of 4 central holes of diameter 0.141 D on a pitch circle diameter of 0.25 D;
- b) a ring of 8 holes of diameter 0.139 D on a pitch circle diameter of 0.56 D;
- c) a ring of 4 holes of diameter 0.1365 D on a pitch circle diameter of 0.75 D;
- d) a ring of 8 holes of diameter 0.110 D on a pitch circle diameter of 0.85 D;
- e) a ring of 8 holes of diameter 0.077 D on a pitch circle diameter of 0.90 D.

The perforated plate thickness is D/8. The flange thickness depends on the application; the outer diameter and flange face surfaces depend on the flange type and application.

Pressure loss across the ZANKER flow conditioner plate may

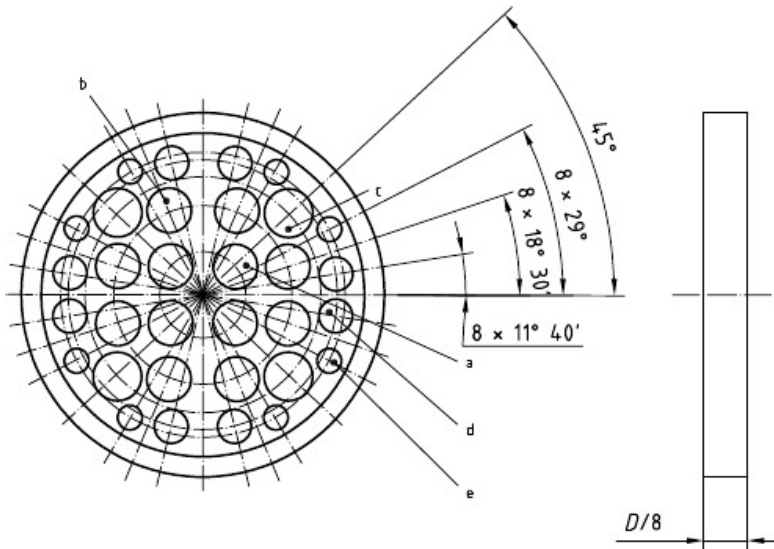

be calculated as:

$$\Delta p = 1,5\rho v^2$$

Whereas,

Δp : Pressure loss across the flow conditioner plate (Pa)

ρ : Density of the fluid [kg/m³]

v: Flow velocity [m/s]

upstream fitting, shall be at least equal to 17D. The ZANKER flow conditioner plate shall be installed so the distance between the downstream face of the conditioner plate and the orifice plate is at least 7.5D.

The distance between the orifice plate and the nearest

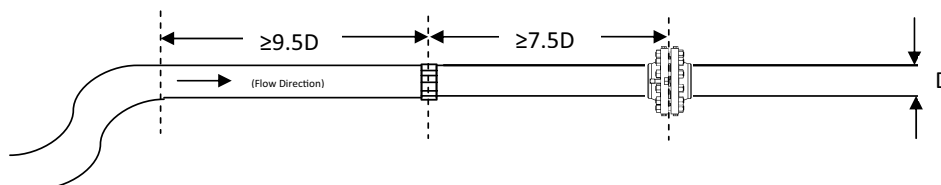



Order Details Flow Straightener/Flow Conditioning Plate (Example: ZUB-FCZ 50 AS MC)

| Model | Line Size | Flange Rating, Material | Options |
|--|--|--------------------------------------|---|
| ZUB-FSB... (Flow straightener) ZUB-FCZ... (Flow Conditioning Plate) | 50 = DN50 (2") | SS = ANSI Class 150 RF, 316L | MC = Material Certificate 3.1 according to EN 10204 NC = Material according to NACE MR-0175/ISO 15156 YY = special option, to be specified |
| | 65 = DN65 (2 ½") | AS = ANSI Class 300 RF, 316L | |
| | 80 = DN80 (3") | BS = ANSI Class 600 RF, 316L | |
| | 1H = DN100 (4") | CS = ANSI Class 900 RF, 316L | |
| | 1F = DN150 (6") | DS = ANSI Class 1500 RF, 316L | |
| | 2H = DN200 (8") | ES = ANSI Class 2500 RF, 316L | |
| | 2F = DN250 (10") | 1S = DN PN16, 316L | |
| | 3H = DN300 (12") | 2S = DN PN25, 316L | |
| | 3F = DN350 (14") | 3S = DN PN40, 316L | |
| | 4H = DN400 (16") | 4S = DN PN63, 316L | |
| | 4F = DN450 (18") | 5S = DN PN100, 316L | |
| | 5H = DN500 (20") | FS = ANSI Class 300 RTJ, 316L | |
| | 6H = DN600 (24") | GS = ANSI Class 600 RTJ, 316L | |
| | | HS = ANSI Class 900 RTJ, 316L | |
| | IS = ANSI Class 1500 RTJ, 316L | | |
| | KS = ANSI Class 2500 RTJ, 316L | | |
| | XX = special version, to be specified | | |



Manifold valves (remote type, machined)

Technical Details

Material: 316SS
 Connection and Size: 1/2" NPT (F)
 Pressure rating: 6000 psig at 38 °C (≈410 bar)
 Temperature range: -54 °C ... +232 °C

3-way Manifold valve

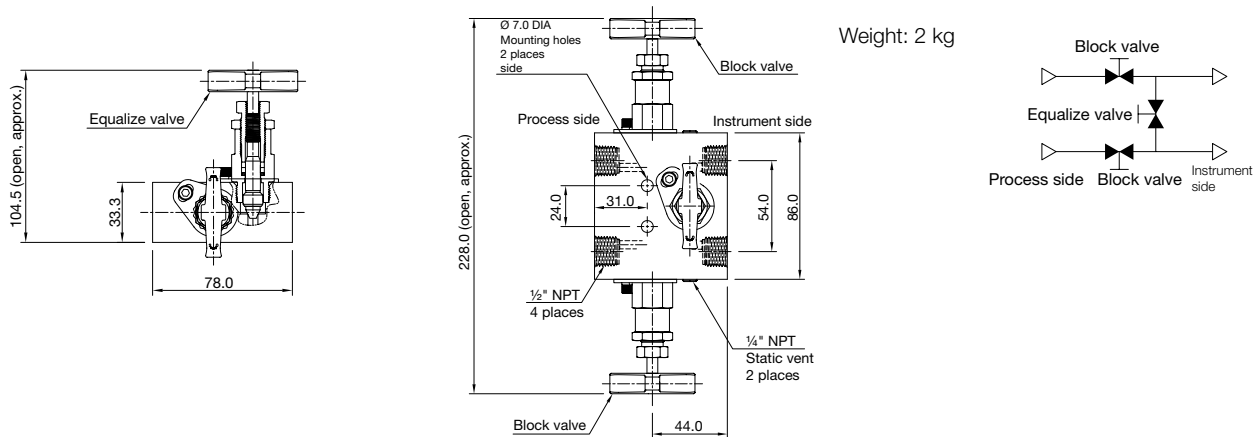

5-way Manifold valve

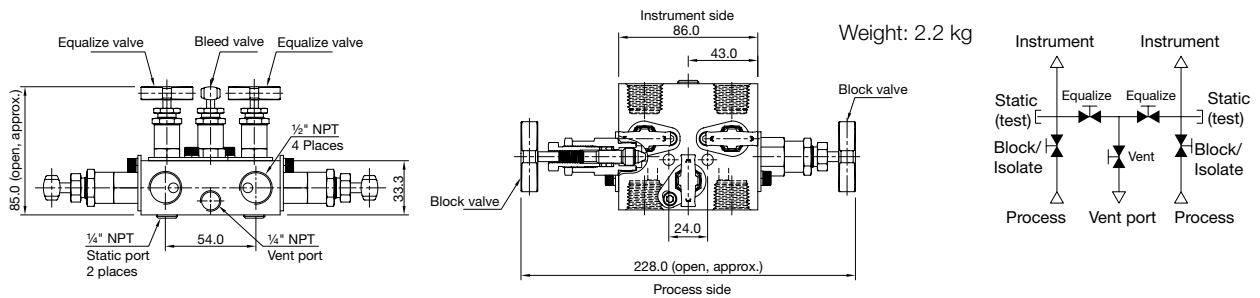

Order Details

| Description | Order number |
|--|--------------|
| 3-way manifold valve, remote mount, machined | ZUB-PAD-3WMR |
| 5-way manifold valve, remote mount, machined | ZUB-PAD-5WMR |



Manifold valves (Direct mount, machined)

Technical Details

Material: 316SS with PTFE packing
 Connection and Size: 1/2" NPT (F) to flange
 Pressure rating: 3000 psig at 232 °C (~210 bar)
 Temperature range: -54 °C ... +232 °C

3-way Manifold valve

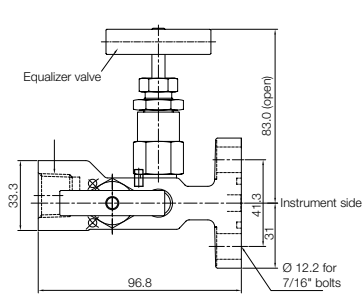
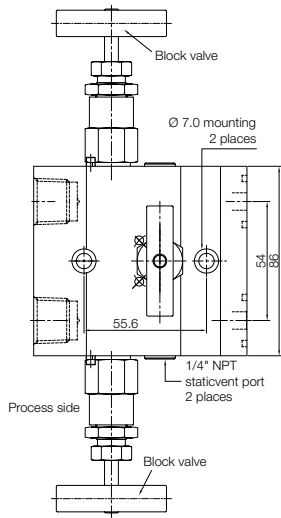

Weight: 1.64 kg

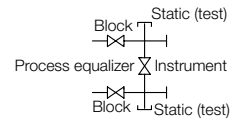

5-way Manifold valve

Weight: 3.1 kg

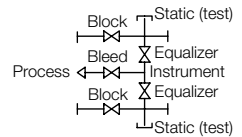
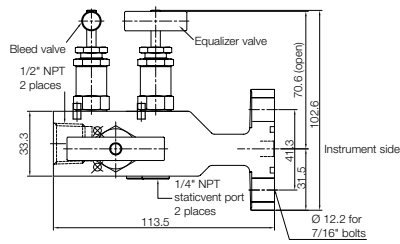
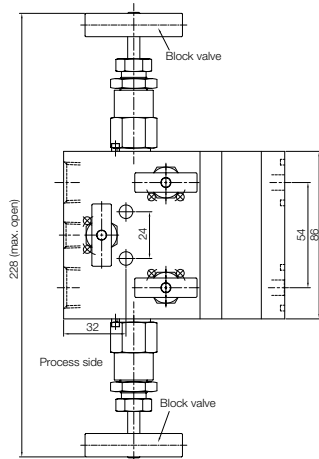

Order Details

| Description | Order number |
|--|---------------------|
| 3-way manifold valve, direct mount, machined | ZUB-PAD-3WMD |
| 5-way manifold valve, direct mount, machined | ZUB-PAD-5WMD |



Manifolds (montage direct, acier usiné)

Technical Details

Material: AISI 316L

Pressure rating: 6000 psi

Temperature range: -73°C... +210°C (PTFE packing), standard

-54°C... +510°C (GRAFOIL® packing), on request

Weight: 2.17 kg

3-way Manifold valve

(inlet: flanged/outlet: flanged according to IEC 61518 Type A)

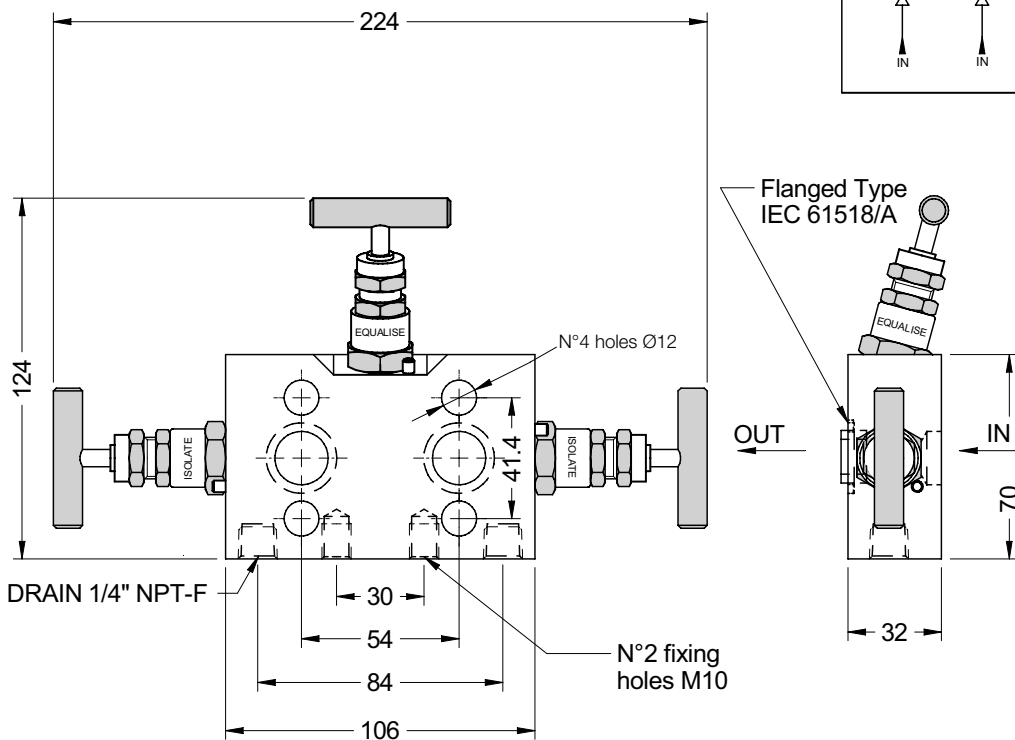
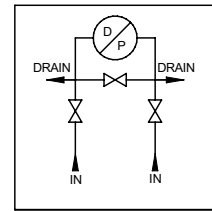

Included accessories:

4 carbon steel screws (stainless steel on request)

2 plugs

2 PTFE gaskets

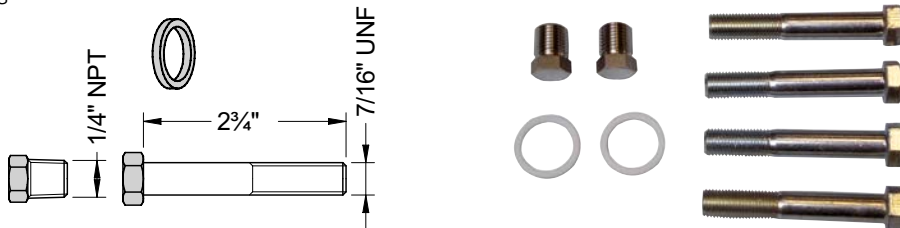

Order Code: 3151CHHHIBAA (PTFE packing)

GRAFOIL® is a registered trademark of Graftech International Holdings Inc.



Manifold valves (Direct mount, machined)

Technical Details

Material: AISI 316L

Pressure rating: 6000 psi

Temperature range: -73°C...+210°C (PTFE packing), standard

-54°C...+510°C (GRAFOIL® packing), on request

Weight: 2.80 kg

5-way Manifold valve

(inlet: 1/2" NPT/outlet: flanged according to IEC 61518 Type A)

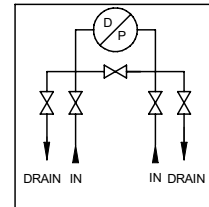
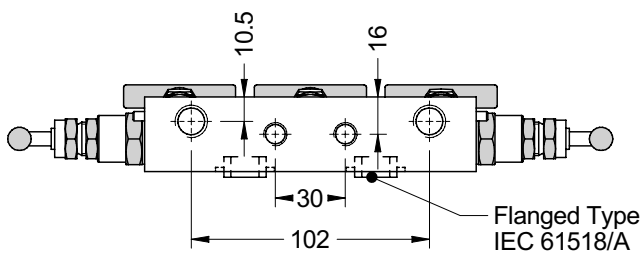
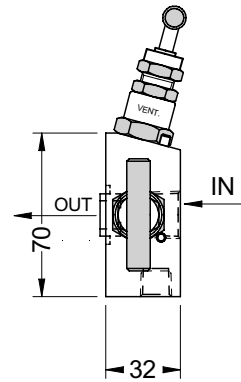
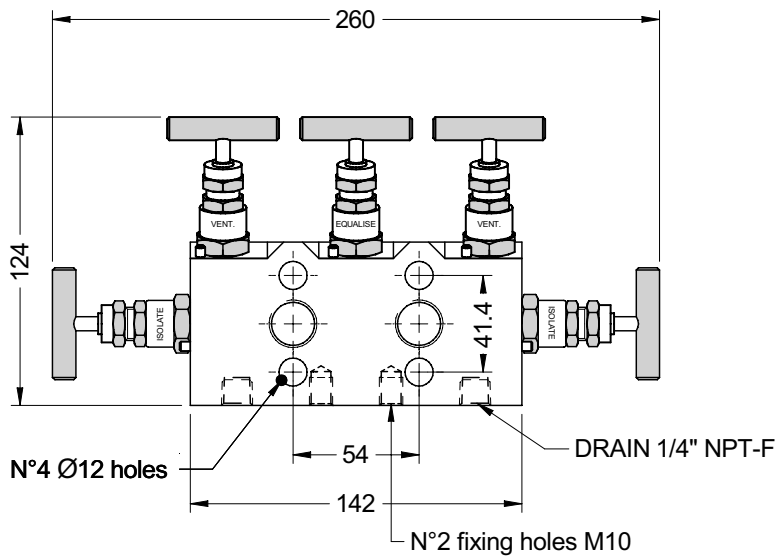

Included accessories:

4 carbon steel screws (stainless steel on request)

2 plugs

2 PTFE gaskets

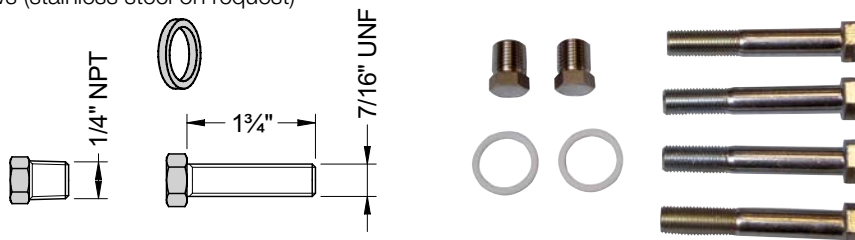

Order Code: 5050CDAHIBAA (PTFE packing)

GRAFOIL® is a registered trademark of Graftech International Holdings Inc.

No responsibility taken for errors; subject to change without prior notice.



Manifold valves (Direct mount, forged)

Technical Details

Material: stainless steel 316L

Pressure rating: 6000 psi

Temperature range: -73°C ... +210°C (PTFE packing), standard

-54°C ... +510°C (GRAFOIL® packing), on request

Weight: 2.25 kg

3-way Manifold valve

(inlet: flanged oval/outlet: flanged according to IEC 61518 Type B)

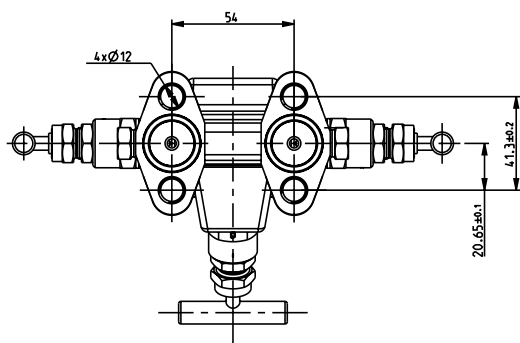
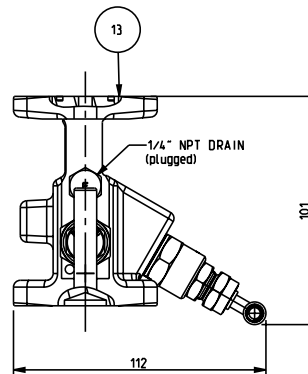
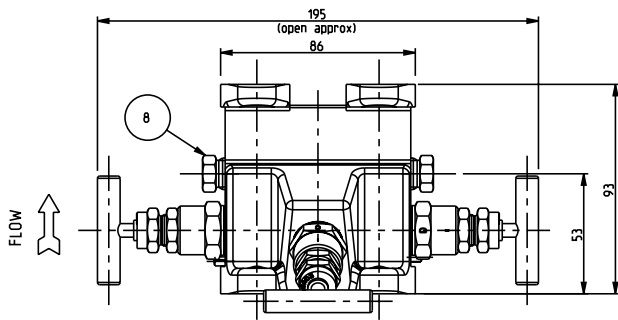
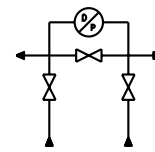
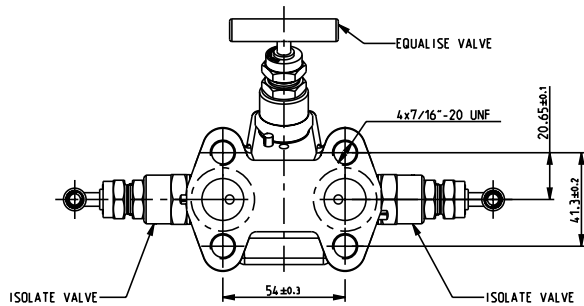

Included accessories:

4 carbon steel screws (stainless steel on request)

2 PTFE gaskets



Order Code: 3454CHHHHBAA (PTFE packing)

GRAFOIL® is a registered trademark of Grafftech International Holdings Inc.

Order Details Mounting brackets

| Description | Order number |
|---|---------------|
| Angle type bracket for PAD/PAS vertical pipe mounting for PAS vertical pipe mounting for PAD incl. U-Clamp for 2" pipe mounting bracket and 2 x mounting nuts/ washers incl. 4 x mounting screws for PAS incl. 4 x mounting screws for PAD | ZUB-PAD/PAS-K |
| Flat type bracket for PAD/PAS horizontal pipe mounting for PAS vertical pipe mounting for PAD incl. U-Clamp for 2" pipe mounting bracket and mounting nuts/ washers incl. 4 x mounting bolts and washers for PAS incl. 4 x mounting bolts for PAD | ZUB-PAD/PAS-L |

Oval Flange (Compact Version)

Dimensions in [mm]

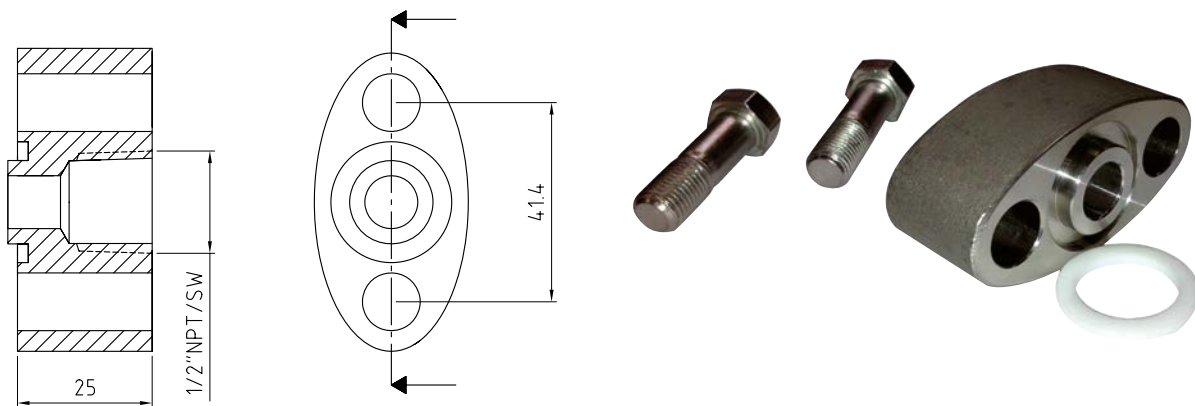

Technical Details

Material: 1.4401 (316 Stainless steel)

Seal: PTFE

Bolts: 2 x mounting screws UNF7/16-20

Order Code: ZUB-PAD-OVF



Condensate Pot (accessory)

Description

The condensate pots prevent direct contact of hot steam with DP transmitter and ensure that the impulse tubing are always full. Both condensate pots are always at the same level to prevent inaccurate readings. The condensate pots are filled with water before commissioning whereas the water level in the pots is maintained by condensing steam in the process.

Technical Details

Material: steel A105 or stainless steel AISI 316L

Volume: 316 cm³

Weight: approx. 1.7 kg



Dimension

ASTM A-105/ASTM AISI 316L

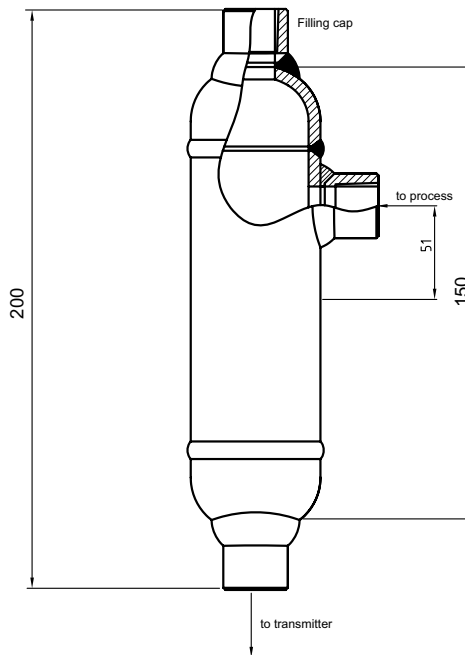

Order Details (Example: ZUB-CP W 1 C VT)

| Model | Connection input/output | Filling cap | Material / PN | Options |
|----------|--|--|---|---|
| ZUB-CP.. | <p>W = welding connection 21.3 mm</p> <p>Y = other (specify in clear text)</p> | <p>1 = 1/2" NPT female with closed plug</p> <p>Y = other (specify in clear text)</p> | <p>C = steel A105; PN100</p> <p>E = stainless steel 316L; PN100</p> <p>R = steel A105; PN250</p> <p>L = stainless steel 316L; PN250</p> | <p>VT = Visual inspection</p> <p>LP = Liquid penetration test</p> <p>PT = Pressure test</p> <p>RT = Radiographic welding test</p> <p>UT = Ultrasonic test</p> <p>HT = hardness test</p> <p>PW* = Post weld heat treatment</p> <p>MT = Magnetic particle test</p> <p>IT = Impact test (Resilience)</p> <p>NC = Material according to NACE MR-0175/ISO15156</p> <p>MC = Material certificate 3.1 according to EN10204</p> |

*not available for material stainless steel



Application Data Sheet (ADS)

| ORIFICE PLATE/ORIFICE FLANGE | |
|---|---|
| GENERAL DATA | |
| Customer: | |
| Project: | |
| Order confirmation No.: | |
| Customer P.O. No.: | |
| Calculation Date: | |
| Model No.: | |
| Tag No.: | |
| PRODUCT DESCRIPTION | |
| Orifice Plate Type: | Pressure Tapping Type: Flange tapping <input type="checkbox"/> D+D/2 tapping <input type="checkbox"/> Corner tapping <input type="checkbox"/> |
| Orifice Plate Material: 316L SS | Line Size: |
| Drain/Vent Diameter: | Wall thickness or Schedule: |
| Process Connection: | Pipe Outer Dia: |
| | Pipe Material: |
| INPUT DATA | |
| Medium name: | |
| Medium state: | Reference Pressure: |
| Gas <input type="checkbox"/> Liquid <input type="checkbox"/> Steam <input type="checkbox"/> | Reference Temperature: |
| Pipe Inner Diameter: | Reference Compressibility: |
| Operating pressure: | Reference Density: |
| Operating Temperature: | |
| Operating Viscosity: | |
| Isentropic Exponent (Cp/Cv): | |
| Compressibility at Flow | |
| Operating Density: | |
| Flow Values (Mention measuring units) | |
| Minimum: | |
| Normal: | |
| Maximum: | (This value is set as Upper Range Value) |
| CALCULATION DATA (Nominal conditions) | |
| Orifice Bore Size: | Bore Reynolds Number (Normal): |
| DP at Min. Flow: | Pipe Reynolds Number (Normal): |
| DP at Normal Flow: | Gas Expansion Factor: |
| DP at Max. Flow: | Permanent Pressure Loss |
| | at Normal Flow: |
| Drain/Vent Corr. Factor: | at Max Flow: |
| Beta: | Velocity at Max. Flow: |
| Discharge Coefficient: | Minimum Accurate Flow: |