



Temperature Sensors for Liquids and Gases



measuring
•
monitoring
•
analysing

TSA



- Measuring range: -40 ... +150 °C
- Measuring accuracy:
±2.5 °C or Pt100 according to IEC 751
- Connection:
G 1/4 ... G 1 female
- Materials: brass, stainless steel
- PTC or Pt100 sensor



T2

KOBOLD companies worldwide:

ARGENTINA, AUSTRIA, BELGIUM, BULGARIA, CANADA, CHILE, CHINA, COLOMBIA, CZECHIA, DOMINICAN REPUBLIC, EGYPT, FRANCE, GERMANY, GREAT BRITAIN, HUNGARY, INDIA, INDONESIA, ITALY, MALAYSIA, MEXICO, NETHERLANDS, PERU, POLAND, ROMANIA, SINGAPORE, SOUTH KOREA, SPAIN, SWITZERLAND, TAIWAN, THAILAND, TUNISIA, TURKEY, USA, VIETNAM

KOBOLD Messring GmbH
Nordring 22-24
D-65719 Hofheim/Ts.
Head Office:
+49(0)6192 299-0
+49(0)6192 23398
info.de@kobold.com
www.kobold.com

Description

The model TSA... temperature sensors respond quickly and operate between -40...+150 °C. A laser-trimmed electronic sensor serves as measuring element in a rugged housing made of brass or stainless steel that is suitable for rough service.

Due to the laser trimming, the output signal of the temperature sensor is strong, therefore no line compensation is required for a supply leads of less than 20 m.

This dependence is linear with a positive temperature coefficient. Control and indicating devices that enable universal service are used to evaluate the output signal.

The temperature sensors are delivered in a housing with internal thread from G 1/4 to G 1 and 1.5 m silicone-rubber-insulated cable.

Application

The model TSA sensors are suitable for service in all applications where temperature monitoring, detection or regulation of gases or liquids is required: for example heat exchangers, heating and ventilation systems, air conditioning and cooling plants, and so forth.

Technical Details

Werkstoff

Housing: brass or stainless steel 1.4301
 Seal: FPM
 Cable: 1.5 m silicone-rubber-insulated

Max. operating pressure: brass 16 bar
 stainless steel 25 bar

Medium temperature: -40... +150 °C

Max. supply current: 1 mA

Measuring accuracy

Model TSA-0...: at 20 °C: ± 0,7 °C over the entire measuring range: ± 2,5 °C

Model TSA-1...: category B according to IEC 751

See resistance thermometers for further details

Special Features

- No line compensation for supply leads < 20 m required
- Linear temperature sensitivity
- Good long-term stability
- Rugged housing for rough service

Dimensions

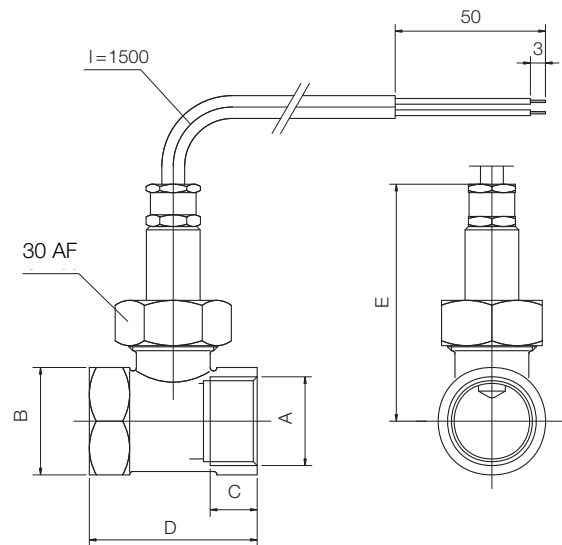

A	B	C	D	E max.
G 1/4	27 AF	10	50	77
G 3/8	27 AF	10	50	77
G 1/2	27 AF	10	50	77
G 3/4	32 AF	15	52	78
G 1	39 AF	15	56	81

Evaluating electronics for temperature sensors

A broad spectrum of transmitters is available for processing the output signal from our temperature sensors. These transmitters convert the signal to a proportional output current (0(4) - 20mA), an analogue or digital display or limit contacts.

Resistance values dependent on temperature

Model TSA-0...

(with 1 mA max. supply current)		(with 1 mA max. supply current)	
Temperature	Resistance (Ω)	Temperature	Resistance (Ω)
-40 °C	1584 ± 12 (1,9 °C)	+60 °C	2314 ± 9 (1,1 °C)
-30 °C	1649 ± 11 (1,7 °C)	+70 °C	2397 ± 10 (1,2 °C)
-20 °C	1715 ± 10 (1,5 °C)	+80 °C	2482 ± 12 (1,4 °C)
-10 °C	1784 ± 9 (1,3 °C)	+90 °C	2569 ± 14 (1,6 °C)
0 °C	1854 ± 8 (1,1 °C)	+100 °C	2658 ± 16 (1,8 °C)
+10 °C	1926 ± 6 (0,8 °C)	+110 °C	2748 ± 18 (2,0 °C)
+20 °C	2000 ± 5 (0,7 °C)	+120 °C	2840 ± 19 (2,0 °C)
+30 °C	2076 ± 5 (0,7 °C)	+130 °C	2934 ± 21 (2,2 °C)
+40 °C	2153 ± 6 (0,8 °C)	+140 °C	3030 ± 23 (2,4 °C)
+50 °C	2233 ± 7 (0,9 °C)	+150 °C	3128 ± 25 (2,5 °C)

Order Details (Example: TSA-0105)

Connection female	Order number (with PTC sensor)		Order number (with Pt100 sensor)	
	Brass	St. steel	Brass	St. steel
G 1/4	TSA-0105	TSA-0205	TSA-1105	TSA-1205
G 3/8	TSA-0110	TSA-0210	TSA-1110	TSA-1210
G 1/2	TSA-0115	TSA-0215	TSA-1115	TSA-1215
G 3/4	TSA-0120	TSA-0220	TSA-1120	TSA-1220
G 1	TSA-0125	TSA-0225	TSA-1125	TSA-1225
G 1 1/4	TSA-0132	TSA-0232	TSA-1132	TSA-1232
G 1 1/2	TSA-0140	TSA-0240	TSA-1140	TSA-1240