



Turbine Wheel Flow Meter for liquids



measuring
•
monitoring
•
analysing

DPE



- Measuring ranges:
5 - 30 ... 50 - 750 l/min water
- Measuring accuracy:
 $\pm 2.5\%$ of full scale
- p_{\max} : PN 40, t_{\max} : 80 °C
- Connection: G 1/2 ... G 3 female
1/2" ... 3" NPT female

Weld-on sleeves:
DN 25 ... DN 80

- Material:
brass, stainless steel
- Viscosity range:
low viscous
- Output:
pulses, 4 - 20 mA,
LED display, contacts



S4

KOBOLD companies worldwide:

ARGENTINA, AUSTRALIA, AUSTRIA, BELGIUM, BULGARIA, CANADA, CHILE, CHINA, COLOMBIA, CZECHIA, EGYPT, FRANCE, GERMANY, GREAT BRITAIN, HUNGARY, INDIA, INDONESIA, ITALY, MALAYSIA, MEXICO, NETHERLANDS, PERU, POLAND, REPUBLIC OF KOREA, ROMANIA, SINGAPORE, SPAIN, SWITZERLAND, TAIWAN, THAILAND, TUNISIA, TURKEY, USA, VIETNAM

KOBOLD Messring GmbH
Nordring 22-24
D-65719 Hofheim/Ts.
Head Office:
+49(0)6192 299-0
+49(0)6192 23398
info.de@kobold.com
www.kobold.com

Description

The KOBOLD flow meter model DPE is used for measuring and monitoring liquids. The device works according the well-known blade wheel principle. The six vane blade wheel is retained axially in a high quality sapphire bearing. The sensor is supplied ready-to-install with pipe fittings or with weld-on sleeves.

The blade wheel is set in motion by the flowing medium. Magnets are embedded hermetically sealed in the ends of the blade wheels. The magnets generate electrical pulses in a Hall-effect sensor mounted outside the flow area.



Fields of Application

- cooling water monitoring
- general mechanical engineering
- waste water treatment
- all heavy goods industry
- chemical industry

Technical Details

Measuring accuracy: ±2.5 % of full scale
 Process temperature: max. 80 °C
 Ambient temperature: max. 80 °C
 Max. operating pressure: PN40 / 20 °C
 Max. pressure loss: DPE-...05: 0.05 bar
 DPE-...10, ...15: 0.03 bar
 DPE-...20: 0.04 bar
 DPE-...25: 0.02 bar
 DPE-...30: 0.01 bar
 Protection: IP65

Materials

Housing: brass
 stainless steel 1.4581
 Seals: brass version: NBR
 Stainless steel version: FPM
 Turbine wheel: PVDF
 Axle: hard metal
 Bearing: sapphire

Electronics

- **Frequency output (..F300)**
 Power supply: 12-28 V_{DC}
 Power consumption: 10 mA
 Pulse output: PNP, open collector, max. 25 mA
 Electr. connection: plug connector M12x1
- **Frequency output with frequency divider**
 Power supply: 24 V_{DC} ± 20 %
 Power consumption: 15 mA
 Pulse output: PNP, open collector, max. 25 mA
 Electr. connection: plug connector M12x1
 Division ratio: 1...1/128, factory set
- **Analogue output (plug-on display option)**
 Power supply: 24 V_{DC} ± 20 %
 Output: 0-20 mA or 4-20 mA,
 2- or 3-wire
 Max. load: 500 Ω
 Electr. connection: plug connector M12x1 or DIN 43 650
 Option: plug-on display (with plug connector
 DIN 43 650 and 4-20 mA output only)

● **Compact electronics**

Display: 3-digit LED
 Analogue output: (0)4...20 mA adjustable, max. 500 Ω
 Switching outputs: 1 (2) semiconductor PNP or NPN, factory set
 Contact operation: N/C / N/O contact, frequency programmable with 2 buttons
 Setting: 24 V_{DC} ± 20 %, 3-wire, approx. 100 mA
 Supply: plug connector M12x1

● **Pointer indicator with analogue output**

Housing: aluminium
 Display: moving-coil instrument, 240° display
 Power supply: 24 V_{DC} ± 20 %
 Output: 0-20 mA or 4-20 mA, 3-wire
 Max. load: 250 Ω
 Electr. connection: plug connector M12x1

● **ADI electronics**

Display: bar graph and 5-digit digital display
 Analogue output: (0)4...20 mA, 0-10 V_{DC}
 2 switching outputs: relay /changeover contact, max. 250 V_{AC}/5 A resistive load, max. 30 V_{DC} / 5 A
 Setting: via 4 buttons
 Supply: 100...240 V_{AC} ± 10 % or 18...30 V_{AC} / 10...40 V_{DC}
 Electr. connection: pluggable terminal block via cable gland

● **DPE-...Exxx (Counter electronic)**

Display: LCD, 2 x 8 digit, illuminated total, part and flow quantities, units selectable
 Analogue output: 0(4)...20 mA adjustable
 Load: max. 500 Ω
 Switching outputs: 2 relays, max. 250 V/5 A/1000 VA
 Settings: via 4 buttons
 Functions: Reset, Min./Max. memory, flow monitor, monitoring for part and total quantity, language
 Supply: 24 V_{DC} ± 20 %, 3-wire
 Power consumption: approx. 170 mA
 Electr. connection: pluggable screw terminals via cable gland

● **DPE-...Gxxx (Dosing electronic)**

Display: LCD, 2 x 8 digit, illuminated total, part and flow quantities, units selectable
 Analogue output: 0(4)...20 mA adjustable
 Load: max. 500 Ω
 Switching outputs: 2 relays, max. 250 V/5 A/1000 VA
 Settings: via 4 buttons
 Functions: dosing (relay S2), start, stop, reset, fine dosing, correction amount, flow switch, total quantity, language
 Supply: 24 V_{DC} ± 20 %, 3-wire
 Power consumption: approx. 170 mA
 Electr. connection: pluggable screw terminals via cable gland

See data sheet ADI-1 for more technical details on ADI evaluating electronics.



Order Details (Example: DPE-1105 G4 F300)

With pipe fittings						Evaluating electronics				
Measuring range max. 3 m/s		Flow rate max. 10 m/s approx. [l/min water]	Model		Connection		Frequency output			
[l/min water]	approx. Frequenz [Hz] at FS		Material brass	Material st. steel	Standard female	Special female	..F300 = frequency output, plug connector M12 x 1 ..F320 = frequency divider 1: 2, plug connector M12 x 1 ..F340 = frequency divider 1: 4, plug connector M12 x 1 ..F390 = frequency divider 1... 1/128, plug connector M12x 1			
5-30	80	100	DPE-1105..	DPE-1205..	..G4.. = G 1/2	..N4.. = 1/2 NPT	Analogue output ..L303 = 0-20 mA output, 3-wire, M12 x 1 plug connector ..L342 = 4-20 mA output, 2-wire, M12 x 1 plug connector ..L343 = 4-20 mA output, 3-wire, M12 x 1 plug connector ..L442 = 4-20 mA output, 2-wire, plug connector DIN 43 650			
10-50	80	180	DPE-1110..	DPE-1210..	..G5.. = G 3/4	..N5.. = 3/4 NPT	Compact electronic* ..C30R = LED display, 2 x open collector, PNP, plug connector M12 x 1 ..C30M = LED display, 2 x open collector, NPN, plug connector M12 x 1 ..C34P = LED display, 4-20 mA, 1 x open collector PNP, plug connector M12 x 1 ..C34N = LED display, 4-20 mA, 1 x open collector NPN, plug connector M12 x 1			
20-80	65	230	DPE-1115..	DPE-1215..	..G6.. = G 1	..N6.. = 1 NPT	Pointer indication, 240°* ..Z300 = 240°-pointer indication, 0-20 mA, plug connector M12x1 ..Z340 = 240°-pointer indication, 4-20 mA, plug connector M12x1			
25-250	140	600	DPE-1120..	DPE-1220..	..G8.. = G 1 1/2	..N8.. = 1 1/2 NPT	Counter electronics ..E34R = LCD, 0(4)-20 mA, 2 x relays			
30-350	135	1000	DPE-1125..	DPE-1225..	..G9.. = G 2	..N9.. = 2 NPT	Dosing electronics ..G34R = LCD, 0(4)-20 mA, 2 x relays			
50-750	110	1600	DPE-1130..	DPE-1230..	..GB.. = G 3	..NB.. = 3 NPT				
With installation adapter not available with compact / ADI electronics						ADI electronics*				
Meas. range [m/s]	approx. frequency [Hz] at max. value	max. flow rate [m/s]	Material brass	Material st. steel	Connection for nominal pipe size		Display	Supply	Output	Contacts
0-3	65 (at DN 25) 140 (at DN 40) 135 (at DN 50) 110 (at DN 80)	10	-	DPE-1200..	..W6.. = DN 25 ..W8.. = DN 40/DN 50 ..WB.. = DN 80	..W6.. = DN 25 ..W8.. = DN 40/DN 50 ..WB.. = DN 80	K = bar graph/ digital display	0 = 100-230 V _{AC/DC} 3 = 18-30V _{AC} 10-40 V _{DC}	0 = without 4 = 0(4)-20 mA, 0-10 V	2 = 2 change-over contacts

* Please specify flow direction in writing.



Turbine Wheel Flow Meter Model DPE

Plug-on display

for model DPE...L442 (with 4-20 mA output and DIN connector)

Description	Order number
4-digit LED, connector DIN 43650, 2-wire, supply through analogue output	AUF-1000
as above however with additional open collector output	AUF-1001

Weights

Sensor

Electronics

Model	Weight	Model	Weight
1/2"	approx. 750 g	Frequency output	130 g
3/4"	approx. 1050 g	Analogue output	130 g
1"	approx. 900 g	Compact electronic	approx. 650 g
1 1/2"	approx. 1200 g	Pointer indication	550 g
2"	approx. 1500 g	ADI electronics	1400 g
3"	approx. 3000 g	E/G electronics	1400 g

Electrical connection

DPE-..F., DPE-..Z., DPE-..L3..3-wire

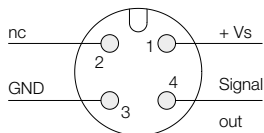

DPE-..L342 2-wire

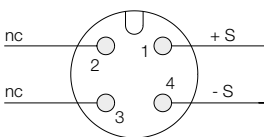

DPE-..C..

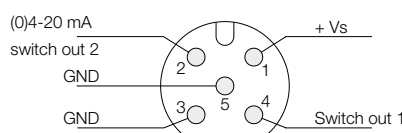

DPE-..L442

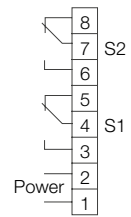
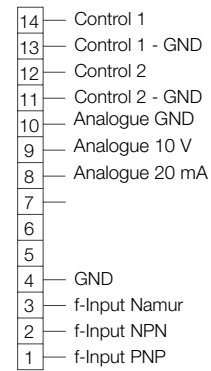
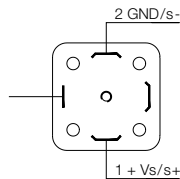

Analogue GND
Analogue 10 V
Analogue 20 mA

Dimensions

Model: DPE-..W.. (with weld-on sleeve)

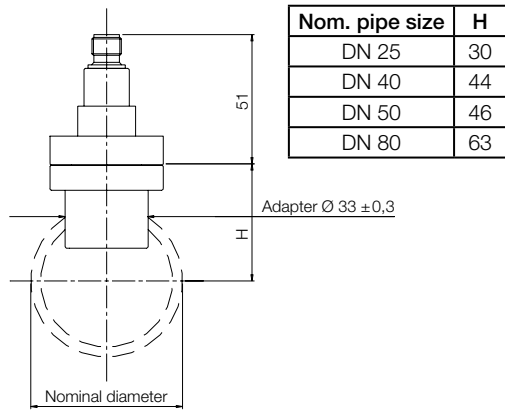

Model: DPE-...L3.. / DPE-..F.. (with analogue output)

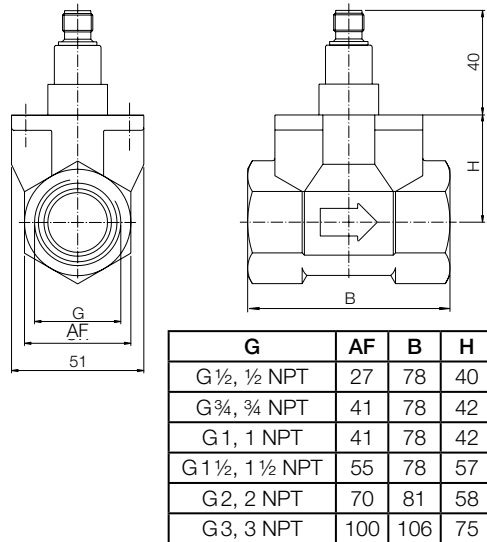

Model: DPE-..L4..

(with analogue output and plug-on display option)

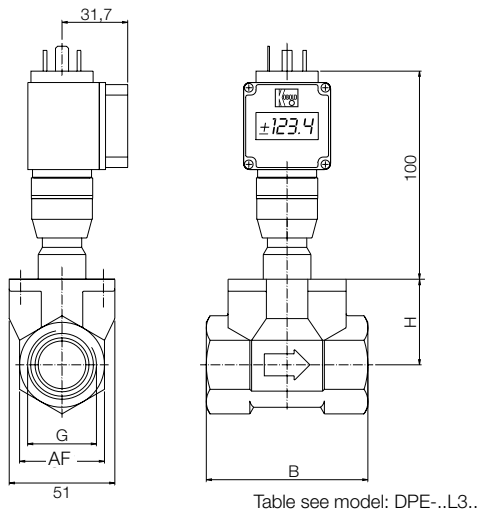

Model: DPE-...C.. (with compact electronic)

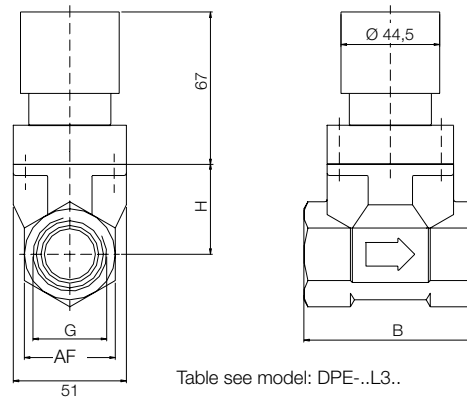

Model: DPE-..K.., ..G.., ..E..

(with ADI evaluating, counter or dosing electronic)

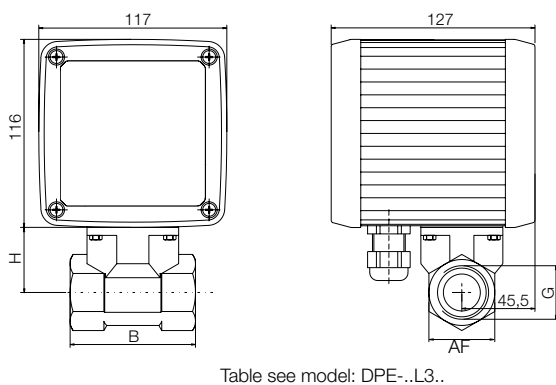

Model: DPE-..Z.. (with pointer indication)

