



Insertion Paddle Wheel Flow Meter/Monitor

for Low Viscous Liquids



measuring
•
monitoring
•
analysing

DOR



- Flow range:
0.25 ... 6300 l/s to 0.4 ... 49000 l/s
- Flow velocity range: 0.3 - 10 m/s
- Viscosity range: low viscous
- p_{\max} : 80 bar; t_{\max} : 150 °C
- Connection: R 1 ½, R 2 male,
1 ½" NPT, 2" NPT male
for pipe sizes: DN 40 ... DN 2500
- Linearity: $\pm 1.5\%$ with well established
flow profile
- Material: stainless steel
- Outputs: pulses, LCD display,
batching, totalising



S4

KOBOLD companies worldwide:

ARGENTINA, AUSTRALIA, AUSTRIA, BELGIUM, BULGARIA, CANADA, CHILE, CHINA, COLOMBIA, CZECHIA, EGYPT, FRANCE, GERMANY, GREAT BRITAIN, HUNGARY, INDIA, INDONESIA, ITALY, MALAYSIA, MEXICO, NETHERLANDS, PERU, POLAND, REPUBLIC OF KOREA, ROMANIA, SINGAPORE, SPAIN, SWITZERLAND, TAIWAN, THAILAND, TUNISIA, TURKEY, USA, VIETNAM

KOBOLD Messring GmbH
Nordring 22-24
D-65719 Hofheim/Ts.
Head Office:
+49(0)6192 299-0
Sales DE:
+49(0)6192 299-500
+49(0)6192 23398
info.de@kobold.com
www.kobold.com



Description

The DOR series insertion paddle wheel flow sensor is a very cost effective instrument for accurately measuring the flow of water or water-like liquids in large pipes.

The sensor is inserted into the process piping via a thread-olet or half nipple fitting. Liquid flow through the pipe results in rotation of the affixed paddle wheel. The rotational speed of the paddle is proportional to the flow velocity, and therefore, proportional to the flowrate in the pipe.

The insertion type design provides a measuring technique that is much less expensive than full bore flowmeters, especially in larger pipe sizes. Insertion paddle wheel sensors are a robust measuring technology that boasts exceptional tolerance to dirt and solids.

The DOR series features an all 316L stainless steel body. The rotor is made of PVDF or PEEK, with a long-life, graphite/PTFE self-lubricating bearing. The DOR has an integral, precision insertion mechanism that allows the installer to insert the rotor to the precise depth in the pipe for optimal readings.

Outputs include NPN open collector frequency, and/or reed contact frequency. Optional indicators include battery powered totalizers, loop powered ratemeter/totalizers and batch controllers.

The DOR-5 is suitable for "hot tap" installation. With its symmetrical design the DOR may be used for bi-directional flow measurement.

Applications

- HVAC: Hot and Chilled water, Fire system and thermal energy monitoring
- Municipal: Water distribution, water management and water treatment
- Irrigation: Water management
- Water treatment: Chlorination, de-salination and mechanical filtration plants, chemical injection systems
- Refineries: Primary flow additive injection, fire and cooling systems
- Power generation: Boiler feed water, steam condensate, process water and water balancing
- Chemical: Process and cooling tower water, chemical and water batching
- Others: Cement manufacturing, diesel fuel transferring, flow testing, fire truck and hydrant flow monitoring, food processing, pulp/paper, mining

Technical Details

Velocity measuring range (linear): 0.3 ... 10 m/s equates to approx. 0.25 ... 49 000 l/s in DN 40 to DN 2500 pipes; 0.15 ... 10 m/s when using the linearisation function of electronic type Z3

Linearity: ±1.5% with well est. flow profile
Repeatability: ±1% of f. s. at factory conditions and optimal straight runs
Max. pressure: 80 bar
Temperature range: -40 ... +100 °C standard, see max. allowable medium temperature table for other options and restrictions

Material

Body: stainless steel 1.4404 (316L)
Rotor: PVDF or PEEK (depending on model)
Rotor shaft: stainless steel 1.4404 (316L)
Bearing: graphite/PTFE
Seals: FPM (standard): -15 ... +200 °C
EPR (ethylene propylene rubber): -20 ... +120 °C, for ketones only
PTFE encapsulated FPM: -20 ... +200 °C
NBR (Nitril): -65 ... +125 °C

Electronics

Output frequency at max. velocity: 220 ... 240 Hz (hall effect and voltage output), 73 ... 80 Hz (reed switch output)
Supply voltage: see electrical output specifications and electronics comparison table
Electronic features: see electronics comparison table
Wiring (standard): 5 core, screened cable, length 3 meters
Transmission distance: 1000 meters maximum, without integrated electronics
Cable entry (terminal box): M20x1.5 (standard), 1/2" NPT adapter (optional)
Protection Class: IP68 (cable connection), IP66/67 (all other electrical connections)
ATEX-approval (option Z4):  II 2G EEx ia IIB T4 (-20 °C ≤ Ta ≤ +60 °C)
Straight piping requirement: Minimum: 10xd (upstream), 5xd (downstream)
Optimal: 25xd (upstream), 10xd (downstream)
Weight: (approx., without electronics): 1.6 kg (DOR-4), 2.5 kg (DOR-5)



Electrical Output Specifications

Hall Effect Sensor Output (FX, NX, QX)

The **Hall Effect Sensor** is a high resolution solid state 3 wire device providing an unsourced, open collector, NPN transistor output. The term "unsourced" means that no voltage is applied to the output from within the flowmeter. It must be pulled to a 'high' or 'on' state by between 5 - 24V_{DC} supplied from an external source, typically the receiving instrument. The pulse output between signal and -0V is a voltage square wave with the high level being the DC voltage available at the open collector and the low level being -0V.

The receiving instrument must incorporate a pull up resistor (typically greater than 10kΩ in most instruments) which ties the open collector to the available DC voltage level when the Hall sensor is not energized. When energized the open collector output is pulled to ground through the emitter (-0V).

Power supply: max. 5 - 24 V_{DC}, max. 20 mA

Voltage Pulse Output (FX)

A self generating 2 wire **voltage pulse output** with 1.5 V voltage spike of approximately 10 microseconds duration is generated with no dependence on rotor speed.

Reed Switch Pulse Output (RX)

The **reed switch** output is a two wire normally open SPST voltage free contact ideal for installations without power or for use in hazardous area locations (simple apparatus) when Intrinsically Safe (I.S.) philosophy is adopted.

Note: when using the reed switch output the liquid temperature must not change at a rate greater than 10°C per minute. In general the reed switch life will exceed 2 billion actuations when switching less than 5V_{DC} at 10mA.

Power supply: max. 30 V_{DC}, 200 mA

Quadrature Pulse Output (QX)

Two Hall Effect sensors arranged to give separate outputs out of phase with one another. The Quadrature output is typically suited to ensure output signal integrity or to measure bi-directional flow.

Power supply: max. 8 - 24 V_{DC}, max. 20 mA

NPN Inductive Pick-up (EX)

Inductive pick-up with non-magnetic rotor for applications with high ferrous content liquids.

Output is 3-wire NPN, 5-24 V_{DC}, 20 mA max.

Electronic with LCD display

Model	..Z1	..Z3	..Z5	..B1
Function	dual totalizer	rate totalizer	rate totalizer	batch controller
Power source				
battery-powered	yes	yes	yes	no
external (drives output, backlighting)	8 - 24 V _{DC}	8 - 24 V _{DC}	8 - 24 V _{DC}	12 - 24 V _{DC}
LCD display				
-line 1 / no. of digits	7.5 mm/5	9 mm/8	17 mm/6	9 mm/8
-line 2 / no. of digits	3.6 mm/8	-	7 mm/8	-
selectable units	yes	yes	yes	yes
decimal point	yes	yes	yes	yes
subscripts displayed	yes	yes	yes	yes
accumulative total	yes	yes	yes	yes
resettable total	yes	yes	yes	no
linearisation	no	yes	no	no
rate display	no	yes	yes	no
backlighting	no	no	yes	no
Input type				
un-powered sensors	see ZOD datasheet			
powered sensors	see ZOD datasheet			
Outputs				
4-20 mA (750 Ω)	no	yes	no	no
high/low flow alarm	no	NPN/PNP	NPN	no
batch end & control	no	no	no	NPN/PNP
pulse outputs	NPN/PNP	NPN/PNP	NPN	NPN/PNP
2 x SPDT relays	no	optional*	no	optional*
Installation				
IP 66/67	yes	yes	yes	yes
cable entries	1 x gland (meter mount) 2 x glands (remote)	3 x M 20	3 x M 16	3 x M 20
intrinsic safe (option)	no	yes	no	no
mounting	meter mount, wall, pipe or panel mounting			
temperature range	-20 ... +80 °C (Option: -20 ... +120 °C)			

*replaces solid state outputs



Insertion Paddle Wheel Flow Meter/Monitor Model DOR

Order Details (Example: **DOR-52 4 F R9 H5 00**)

Model/ Housing material	Rotor/shaft	Sealing Material	Mechanical Connection	Output/ Electrical Connection	Electronics	Special Options
DOR-42 (for pipe size 40...900 mm) stainless steel			DOR-42 R8 = R 1½ male R9 = R2 male N8 = 1½"NPT male N9 = 2" NPT male	F1 = NPN OC +1,5 V-Pulse + 3 m cable (standard) F2 = NPN OC + 1,5 V-Pulse + 10 m cable F3 = NPN OC + 1,5 V-Pulse + 20 m cable F4 = NPN OC + 1,5 V-Pulse + 50 m cable F5 = NPN OC + 1,5 V-Pulse + terminal box on stem kit F6 = NPN OC + 1,5 V-Pulse + integral electronic ZOD on stem kit N5¹⁾ = NPN OC + terminal box on stem kit + High Temp. Sensor (+150 °C) R1 = reed switch + 3 m cable R2 = reed switch + 10 m cable R3 = reed switch + 20 m cable R4 = reed switch + 50 m cable R5 = reed switch + terminal box on stem kit R6²⁾ = reed switch + integral I. S. electronic ZOD-Z3 + ATEX on stem kit Q1 = 2xNPN OC + 3 m cable Q2 = 2xNPN OC + 10 m cable Q3 = 2xNPN OC + 20 m cable Q4 = 2xNPN OC + 50 m cable Q5 = 2xNPN OC + terminal box on stem kit E1 = non magnetic rotor for ferrous media, NPN, 3 m cable E2 = non magnetic rotor for ferrous media, NPN, 10 m cable E3 = non magnetic rotor for ferrous media, NPN, 20 m cable E4 = non magnetic rotor for ferrous media, NPN, 50 m cable E5 = non magnetic rotor for ferrous media, NPN, terminal box on stem kit XX = special option (specified in clear text, consult factory)	00 = frequency output only Z1³⁾ = Electronic ZOD-Z1 Z3³⁾ = Electronic ZOD-Z3 Z4⁴⁾ = Elect- ronics "ZOD-Z3" + ATEX Z5³⁾ = Electronic ZOD-Z5 B1³⁾ = Electronic ZOD-B1 XX = special option (specified in clear text)	none = without Y = specified in clear text
DOR-52 (for pipe size 50...2500 mm) stainless steel	2 = PVDF/st. steel (max. 100 °C) 4 = PEEK/st. steel (max. 150 °C) X = special (on request)	F = FPM (standard) N = NBR P = PTFE encapsu- lated FPM E = EPR (for keto- nes only)	DOR-52 R9 = R2 male N9 = 2" NPT male			

¹⁾ only possible with PEEK rotor
²⁾ only possible with electronics option "Z4"
³⁾ only for output F6
⁴⁾ only for output R6



Process Temperature Limits with Rotor and Output Options*

Rotor	Max. medium temperature
PVDF	100 °C
PEEK	150 °C
Output/Pick-up type	
F1 -F4 R1 - R4 Q1 - Q4	100 °C
N5, Q5	150 °C
E1 - E4	85 °C
R5, R6, F5, F6, E5	125 °C

*choose PEEK rotor for all options > 100 °C, keep temperature limits of sealing materials also in mind while selecting different options.

Standard Installation

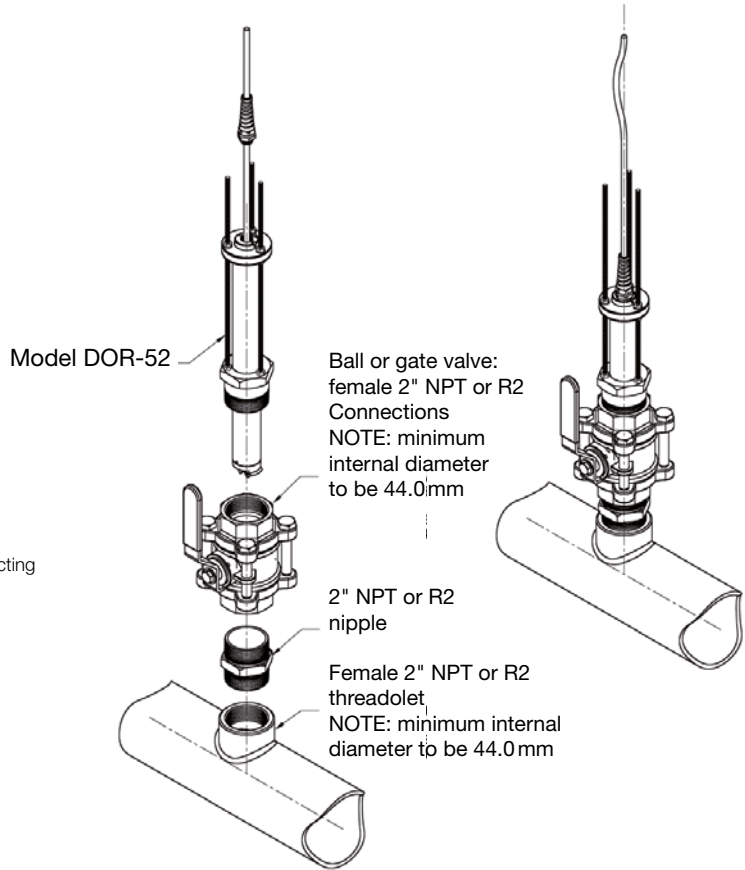
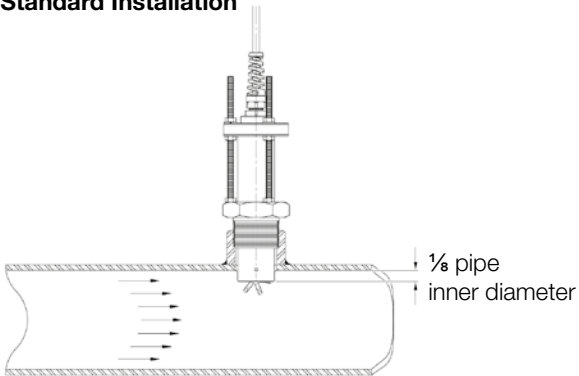

Installation Straight Piping Requirements

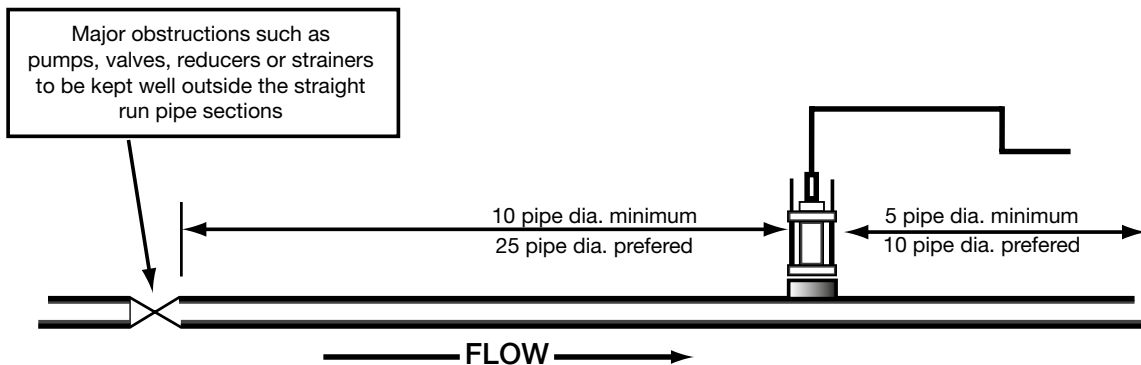



Insertion Paddle Wheel Flow Meter/Monitor Model DOR

Dimensions [mm]

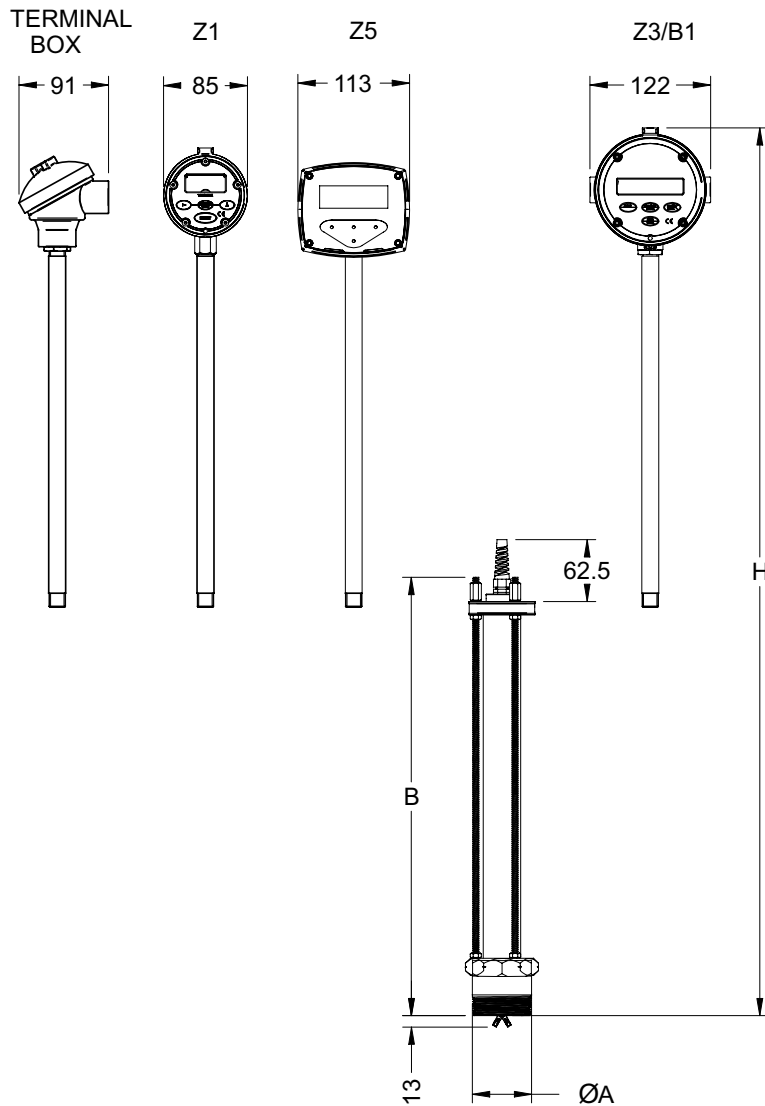

All dimensions in mm, ± 2 mm

	DOR-42	DOR-52
ØA	1 ½" or 2" NPT/R2	2" NPT/R2
B	198	444
Configuration	H	H
Terminal Box	385	869
Z1	394	880
Z3/B1	415	900
Z5	380	865