

(4) 3/4" [19.05] DIA BOLT HOLES LOCATED AS SHOWN ON 14.12 [358.6] B.C.D.

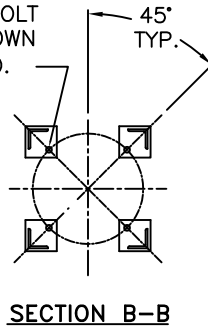

REVISIONS				
REV	DESCRIPTION	BY	ECO	DATE
H	UPDATE DRAWING NOTE 1	FJM	0121642	04/01/16

ITEM	PART NAME	MATERIAL
1	BODY	SA53 GR E/B
2	COVER	SA516 GR 70
3	O-RING P/N 2375035193	BUNA-N
4	PIN	SA193 B7 ZINC PL
5	SNAP RING	STEEL ZINC PL
6	BASKET RESTRAINER P/N L0001753	316 SS
7	FILTER BAG RETAINER	316 SS
8	EYE BOLT	SA193 B7 ZINC PL
9	HEX NUT	SA194 2H ZINC PL
10	WASHER	STEEL ZINC PL
11	SPRING ASSISTED MECHANISM	STAINLESS STEEL

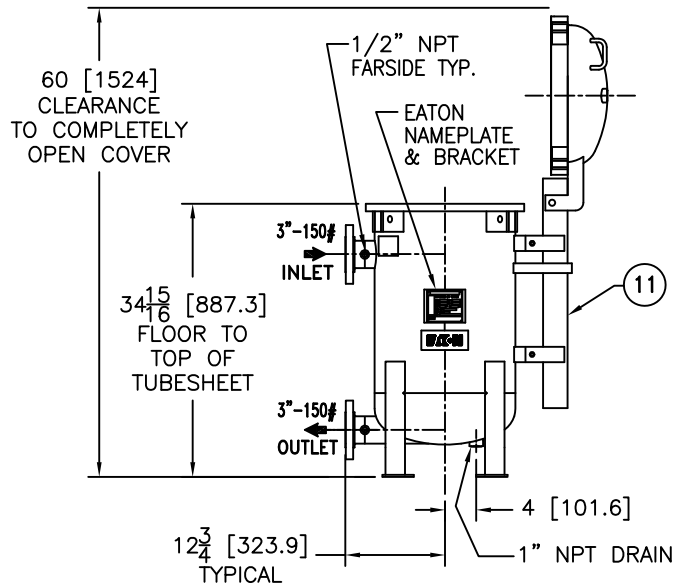
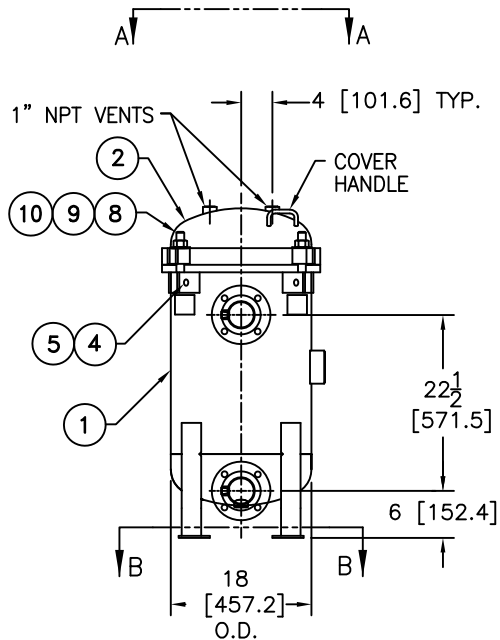

NOTES:

- UNITS ARE DESIGNED, FABRICATED AND "U" STAMPED IN ACCORDANCE WITH THE ASME BOILER & PRESSURE VESSEL CODE SECTION VIII, DIVISION 1, IN COMPLIANCE TO CURRENT MANDATORY EDITION.
- INLET / OUTLET FLANGE CONNECTIONS PER ANSI B 16.5.
- DESIGN PRESSURE: 150 PSI (MAWP)
DESIGN TEMPERATURE 250° F.
MDMT - -20° F @ 150 PSI.
- DIMENSIONS SHOWN IN [] ARE IN MILLIMETERS AND FOR REFERENCE ONLY. ACCEPTANCE OF THIS PART WILL BE BASED ON "INCH" UNITS & TOLERANCES ONLY.
- ALL BOLT HOLES ARE TO STRADDLE NATURAL CENTERLINES.
- APPROX. WEIGHT (DRY) 460 LBS (208 kgs)
- APPROX. SHIPPING WEIGHT 575 LBS (260kgs)
- PAINT PER EATON STANDARD ES-301.

TOLERANCES (UNLESS OTHERWISE SPECIFIED)	
DECIMAL:	.X ± .030 .XX ± .010 .XXX ± .005
FRACTIONAL:	± 1/16
NOZZLE Ø TO FLOOR:	1/8" < 4' > 1/4"
FACE TO FACE:	1/8" < 4' > 1/4"
ANGULAR:	± 1°
FLANGES (H/V):	± 1/2°
VESSEL OVERALL HT:	1"

BOLT HOLES MUST STRADDLE Ø MACHINED PARTS TO BE FREE OF BURRS FOR ADDITIONAL TOLERANCE DETAILS REF. ES-211, ES-222 AND ES-223

REVIEWED FOR CLASSIFICATION PER PR-4

CRITICAL SIGNIFICANT

CUSTOMER INFO	
NAME	
P.O. NO.	
S.O. NO.	
QUANTITY	
PART NO.	F3AV030002L

DRAWN BY	FJM
SCALE	AS DRAWN
RESTRICTION	RESTRICTED
SHEET	1 OF 1
PROJECTION	THIRD ANGLE

VESSEL CODE: MBF-0302-CS10-030A-UT-13HE-LOOP			
EATON		HYDRAULICS GROUP FILTRATION DIVISION GALESBURG, MICHIGAN, USA • TINTON FALLS, NEW JERSEY, USA	
TITLE MAXILINE MBF0302HE FILTER VESSEL 3" 150# RF INLET/TANGENTIAL OUTLET MATIERAL CARBON STEEL			
DATE	SIZE	DWG FILENAME	REV
06/13/03	A	HE0303TCL	H

EATON CORPORATION - CONFIDENTIAL AND PROPRIETARY NOTICE TO PERSONS RECEIVING THIS DRAWING AND/OR TECHNICAL INFORMATION
THIS DOCUMENT, INCLUDING THE DRAWING AND INFORMATION CONTAINED THEREIN IS CONFIDENTIAL AND IS THE EXCLUSIVE PROPERTY OF EATON AT ANY TIME. BY TAKING THE POSSESSION OF THIS DOCUMENT THE RECIPIENT ACKNOWLEDGES AND AGREES THAT THIS DOCUMENT CANNOT BE USED IN ANY MANNER ADVERSE TO THE INTEREST OF EATON AND THAT NO PORTION OF THIS DRAWING MAY BE COPIED OR OTHERWISE REPRODUCED WITHOUT THE PRIOR WRITTEN CONSENT OF EATON, IN THE CASE OF CONFLICTION CONTRACTUAL PROVISIONS, THIS NOTICE SHALL GOVERN THE STATUS OF THIS DOCUMENT.
2014 EATON CORPORATION - ALL RIGHTS RESERVED.