

Low profile, general purpose accelerometer

787BM8-M12



Key features

- Comes with industry popular M12 connector
- Corrosion resistant
- Hermetically sealed
- Case isolated
- ESD protection
- Rugged design

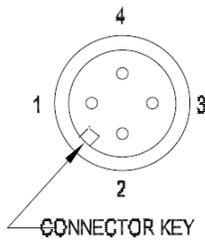
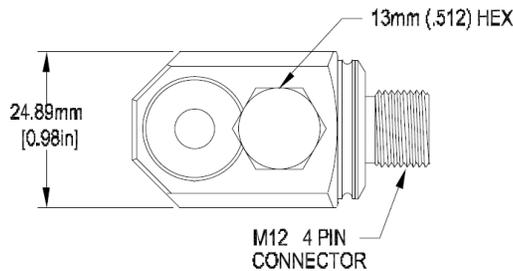

Connections	
Function	Connector pin
power / signal	1
common	2
N/C	3
N/C	4
ground	shell

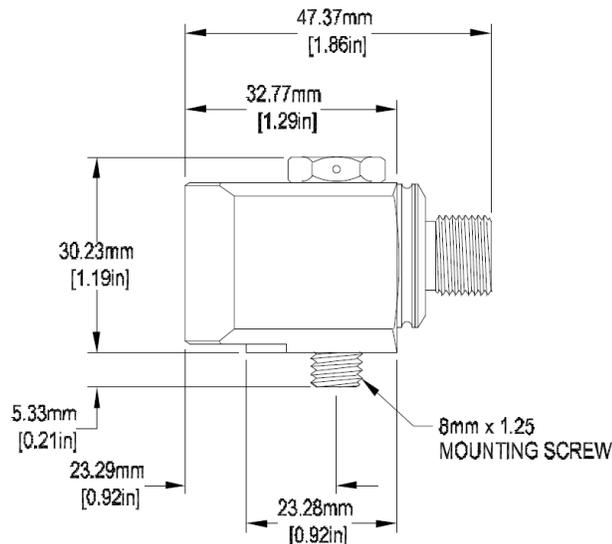

Certifications



Note: Due to continuous process improvement, specifications are subject to change without notice. This document is cleared for public release.

Wilcoxon Sensing Technologies
 20511 Seneca Meadows Parkway
 Germantown, MD 20876
 info@wilcoxon.com

Tel: (301) 330 8811
 Fax: (301) 330 8873
 www.wilcoxon.com

Wilcoxon Sensing Technologies
 An Amphenol Company

Low profile, general purpose accelerometer

787BM8-M12

SPECIFICATIONS

Sensitivity, ±10%, 25° C	100 mV/g
Acceleration range	80 g peak
Amplitude nonlinearity	1%
Frequency response:	1.0 - 5,000 Hz
± 10%	0.7 - 10,000 Hz
± 3 dB	
Resonance frequency	22 kHz
Transverse sensitivity, max	5% of axial
Temperature response:	-10%
-25° C	+10%
+120° C	
Voltage source	18 - 30 VDC
Current regulating diode	2 - 10 mA
Electrical noise, equiv. g:	
Broadband 2.5 Hz to 25 kHz	700 µg
Spectral 10 Hz	10 µg/√Hz
100 Hz	5 µg/√Hz
1000 Hz	5 µg/√Hz
Output impedance, max	100 Ω
Bias output voltage	12 VDC
Grounding	case isolated, internally shielded
Temperature range	-50 to +120° C
Vibration limit	500 g peak
Shock limit	5,000 g peak
Electromagnetic sensitivity, equiv g, max	70 µg/gauss
Sealing	hermetic
Base strain sensitivity, max	0.002 g/µstrain
Sensing element design	PZT ceramic / shear
Weight	145 grams
Case material	316L stainless steel
Mounting	M8 thread captive screw
Output connector	4-pin, M12 style
Mating connector	M12 style
Recommended cabling	J10 / J9T2A

Contact

Wilcoxon Sensing
Technologies

20511 Seneca Meadows Parkway
Germantown, MD 20876, USA

Tel: +1 301 330 8811
Fax: +1 301 330 8873

info@wilcoxon.com

www.wilcoxon.com

Accessories supplied:

- M8 thread captive hex head screw
- Calibration data (level 2)

Note: Due to continuous process improvement, specifications are subject to change without notice.
This document is cleared for public release.

Wilcoxon Sensing Technologies
20511 Seneca Meadows Parkway
Germantown, MD 20876
info@wilcoxon.com

Tel: (301) 330 8811
Fax: (301) 330 8873
www.wilcoxon.com

Wilcoxon Sensing Technologies
An Amphenol Company