

# SIEMENS

## SITRANS

### Sensing Heads SITRANS WFS300

#### Operating Instructions

<u>Introduction</u>	<b>1</b>
<u>Safety notes</u>	<b>2</b>
<u>Description</u>	<b>3</b>
<u>Installing/mounting</u>	<b>4</b>
<u>Connecting</u>	<b>5</b>
<u>Commissioning</u>	<b>6</b>
<u>Service and maintenance</u>	<b>7</b>
<u>Diagnosing and troubleshooting</u>	<b>8</b>
<u>Technical specifications</u>	<b>9</b>
<u>Dimension drawings</u>	<b>10</b>
<u>Appendix A</u>	<b>A</b>
<u>Product documentation and support</u>	<b>B</b>

## Legal information

### Warning notice system

This manual contains notices you have to observe in order to ensure your personal safety, as well as to prevent damage to property. The notices referring to your personal safety are highlighted in the manual by a safety alert symbol, notices referring only to property damage have no safety alert symbol. These notices shown below are graded according to the degree of danger.

 <b>DANGER</b>
indicates that death or severe personal injury <b>will</b> result if proper precautions are not taken.

 <b>WARNING</b>
indicates that death or severe personal injury <b>may</b> result if proper precautions are not taken.

 <b>CAUTION</b>
indicates that minor personal injury can result if proper precautions are not taken.

<b>NOTICE</b>
indicates that property damage can result if proper precautions are not taken.

If more than one degree of danger is present, the warning notice representing the highest degree of danger will be used. A notice warning of injury to persons with a safety alert symbol may also include a warning relating to property damage.

### Qualified Personnel

The product/system described in this documentation may be operated only by **personnel qualified** for the specific task in accordance with the relevant documentation, in particular its warning notices and safety instructions. Qualified personnel are those who, based on their training and experience, are capable of identifying risks and avoiding potential hazards when working with these products/systems.

### Proper use of Siemens products

Note the following:

 <b>WARNING</b>
Siemens products may only be used for the applications described in the catalog and in the relevant technical documentation. If products and components from other manufacturers are used, these must be recommended or approved by Siemens. Proper transport, storage, installation, assembly, commissioning, operation and maintenance are required to ensure that the products operate safely and without any problems. The permissible ambient conditions must be complied with. The information in the relevant documentation must be observed.

### Trademarks

All names identified by ® are registered trademarks of Siemens AG. The remaining trademarks in this publication may be trademarks whose use by third parties for their own purposes could violate the rights of the owner.

### Disclaimer of Liability

We have reviewed the contents of this publication to ensure consistency with the hardware and software described. Since variance cannot be precluded entirely, we cannot guarantee full consistency. However, the information in this publication is reviewed regularly and any necessary corrections are included in subsequent editions.

# Table of contents

<b>1</b>	<b>Introduction</b> .....	<b>5</b>
1.1	The manual .....	5
<b>2</b>	<b>Safety notes</b> .....	<b>6</b>
2.1	General safety instructions.....	6
2.2	Installation in hazardous areas .....	6
<b>3</b>	<b>Description</b> .....	<b>10</b>
3.1	SITRANS WFS300 .....	10
3.2	Principle of operation.....	10
<b>4</b>	<b>Installing/mounting</b> .....	<b>12</b>
4.1	Sensing head .....	12
4.1.1	Side mount.....	12
4.1.2	Base mount .....	13
4.2	Sensing plate.....	13
4.3	Viscous damper .....	14
<b>5</b>	<b>Connecting</b> .....	<b>15</b>
5.1	Unit without LVDT conditioner card.....	15
5.2	Unit with sensing head mounted LVDT conditioner card .....	16
5.3	Unit with remote-located LVDT conditioner card.....	19
<b>6</b>	<b>Commissioning</b> .....	<b>23</b>
6.1	Calibration.....	23
6.2	LVDT Output.....	24
6.3	Span test .....	25
6.4	Sensing head level test .....	25
6.5	Integrator calibration .....	26
6.6	Zero calibration .....	26
6.7	Span calibration.....	26
<b>7</b>	<b>Service and maintenance</b> .....	<b>28</b>
7.1	Maintenance .....	28
7.2	Spare parts .....	28
7.3	Inner gasket replacement.....	29
<b>8</b>	<b>Diagnosing and troubleshooting</b> .....	<b>30</b>
8.1	Range springs .....	30

8.2	Troubleshooting .....	31
8.3	Linearity .....	31
<b>9</b>	<b>Technical specifications.....</b>	<b>33</b>
9.1	Performance .....	33
9.2	Construction.....	33
9.3	Input .....	34
9.4	Output .....	34
9.5	Operating conditions .....	34
9.6	Approvals .....	35
<b>10</b>	<b>Dimension drawings.....</b>	<b>36</b>
10.1	WFS300 side mount outline and mounting.....	36
10.2	WFS300 base mount outline and mounting.....	37
<b>A</b>	<b>Appendix A .....</b>	<b>38</b>
A.1	WFS300 part identification diagram .....	38
<b>B</b>	<b>Product documentation and support .....</b>	<b>40</b>
B.1	Product documentation .....	40
B.2	Technical support .....	41
	<b>Index.....</b>	<b>42</b>

---

**Note**

The SITRANS sensing head is to be used only in the manner outlined in this manual, otherwise protection provided by equipment may be impaired.

- It is your responsibility to read this manual before installing and starting up any component of the weighing system to which the sensing head is being applied.
- 

---

**Note****For industrial use only**

This product is intended for use in industrial areas. Operation of this equipment in a residential area may cause interference to several frequency based communications.

---

## 1.1 The manual

This manual covers only sensing head installation, operation, and maintenance procedures. Flowmeter and integrator instruction manuals are available for download from our web site:

Siemens weighing (<http://www.siemens.com/weighing>)

Follow these operating instructions for quick, trouble-free installation, and maximum accuracy and reliability of your device.

We always welcome suggestions and comments about manual content, design, and accessibility. Please direct your comments to:

Technical publications ([pi-documentation-service.industry@siemens.com](mailto:pi-documentation-service.industry@siemens.com))

## Safety notes

### 2.1 General safety instructions

 <b>CAUTION</b>
Correct, reliable operation of the product requires proper transport, storage, positioning and assembly as well as careful operation and maintenance. Only qualified personnel should install or operate this instrument.

---

**Note**

Alterations to the product, including opening or improper repairs of the product, are not permitted.

If this requirement is not observed, the CE mark and the manufacturer's warranty will expire.

---

### 2.2 Installation in hazardous areas

 <b>WARNING</b>
Equipment used in hazardous areas must be Ex-approved and marked accordingly. It is required that the special conditions for safe use provided in the manual and in the Ex certificate are followed.

## WFS300 nameplate

### Note

The nameplate shown is a typical example. Please check the nameplate on your device for your specific device configuration.





**WARNING**

Make sure the hazardous area approval is suitable for the environment in which the device will be installed.

## Instructions specific to hazardous area installations

(Reference European ATEX Directive 94/9/EC, Annex II, 1/0/6)

The following instructions apply to equipment covered by certificate number FM13ATEX0032X, or certificate number FM14ATEX0027X, or both if neither certificate is specified.

1. For use and assembly, refer to the main instructions.
2. The equipment is certified for use as Category 3G equipment per FM13ATEX0032X.
3. Per FM13ATEX0032X, the equipment may be used with flammable gases and vapors with apparatus group IIA, IIB, and IIC, and temperature classes T1, T2, T3, T4, T5, and T6 in zone 2 hazardous locations.

## 2.2 Installation in hazardous areas

4. The equipment is certified for use as Category 2D equipment per FM14ATEX0027X.
5. Per FM14ATEX0027X, the equipment has a degree of ingress protection of IP64 and a temperature class of T70°C and may be used with flammable, conductive dusts in zone 21 and 22 hazardous locations.
6. The equipment is certified for use in an ambient temperature range of -40°C to +60°C.
7. The equipment has not been assessed as a safety related device (as referred to by Directive 94/9/EC Annex II, clause 1.5).
8. Installation and inspection of the equipment shall be carried out by suitably trained personnel in accordance with the applicable code of practice.
9. Repair of the equipment shall be carried out by suitably trained personnel in accordance with the applicable code of practice.
10. Components to be incorporated into or used as replacements in the equipment shall be fitted by suitably trained personnel in accordance with the manufacturer's documentation.
11. Each certificate number has an 'X' suffix, which indicates that special conditions for safe use apply. Those installing or inspecting the equipment must have access to the certificates.
12. If the equipment is likely to come into contact with aggressive substances, then it is the responsibility of the user to take suitable precautions that prevent it from being adversely affected, thus ensuring that the type of protection is not compromised.
  - Aggressive substances:  
for example, acidic liquids or gases that may attack metals, or solvents that may affect polymeric materials.
  - Suitable precautions:  
for example, establishing from the material's data sheet that it is resistant to specific chemicals.

### Special conditions for safe use

#### Certificate number FM13ATEX0032X

The 'X' suffix to certificate number FM13ATEX0032X relates to the following special conditions for safe use:

- The enclosure is non-conducting and, under certain extreme conditions, may generate an ignition-capable level of electrostatic charges. The user shall ensure that the equipment is not installed in a location where it may be subjected to external conditions (such as high-pressure steam) which might cause a build-up of electrostatic charges on non-conducting surfaces. Additionally, cleaning of the equipment should be done only with a damp cloth.
- Indoor use only. Additionally, the user shall ensure that the equipment is not installed in a location where it is continuously exposed to ultraviolet light.

#### Certificate number FM14ATEX0027X

The 'X' suffix to certificate number FM14ATEX0027X relates to the following special conditions for safe use:

- The enclosure is non-conducting and, under certain extreme conditions, may generate an ignition-capable level of electrostatic charges. The user shall ensure that the equipment is not installed in a location where it may be subjected to external conditions (such as high-



pressure steam) which might cause a build-up of electrostatic charges on non-conducting surfaces. Additionally, cleaning of the equipment should be done only with a damp cloth.

- Indoor use only. Additionally, the user shall ensure that the equipment is not installed in a location where it is continuously exposed to ultraviolet light.
- Magnesium, titanium or zirconium may be used at the accessible surface of the equipment. In the event of rare incidents, ignition sources due to impact and friction sparks could occur. This shall be considered when the WFS300 is being installed in locations that specifically require Equipment Protection Level Db.

## Description

### 3.1 SITRANS WFS300

SITRANS WFS300 sensing head is an out-of-process sensing element used for continuous in-line weighing of powdered or granular dry bulk solid materials. It is used with the 40 tph versions of SITRANS WF330 (general purpose), WF340 (vertical material drop), and WF350 (aerated gravity conveyor) dry solids flowmeters.

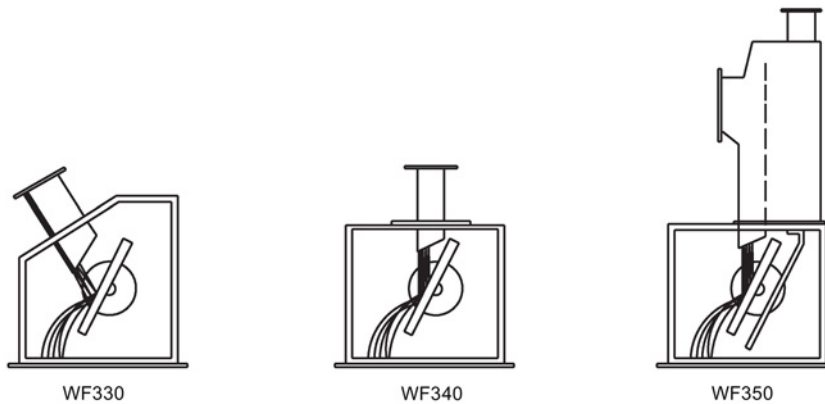

### 3.2 Principle of operation

SITRANS sensing heads are used for continuous weighing of dry bulk solid materials. The material is directed toward the sensing plate. The horizontal impact force of the material deflects the sensing plate, displacing the core of the sensing head LVDT (linear variable differential transformer). The LVDT produces an output signal which is proportional to material flowrate. A viscous fluid damper prevents oscillation of the mechanism and provides mechanical damping of pulsating material flow.

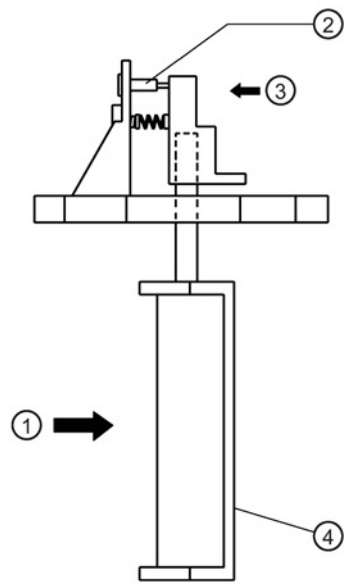

- ① Impact force
- ② LVDT

- ③ Moving beam travel
- ④ Sensing plate

## Installing/mounting



### CAUTION

Installation shall be performed only by qualified personnel in accordance with local governing regulations.

### 4.1 Sensing head

The WFS300 sensing head is available in two models: side mount and base mount. The base mount version should be used if the flowmeter will be subjected to excessive vibration, for flow rates below 1 t/h, or if handling product temperatures above 60 °C. The side mount version is factory-installed on Siemens flowmeters designed for side mount sensing heads.

#### 4.1.1 Side mount

1. With the flowmeter housing installed, remove the sensing head cover.
2. Loosen the four sensing head mounting bolts.
3. Place a spirit level on the flat top of the sensing head frame: adjust the level by rotating the sensing head, and retighten the mounting bolts.

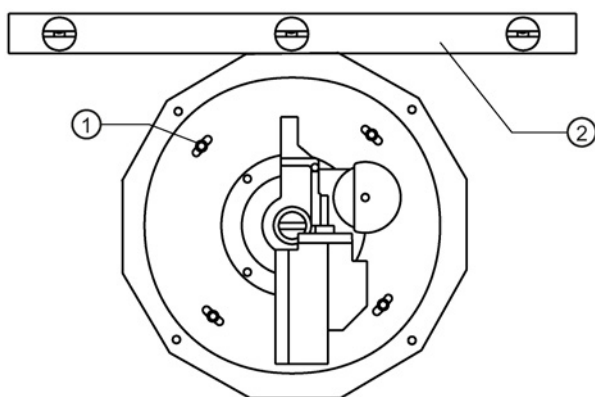

① Mounting bolts

② Spirit level

### 4.1.2 Base mount

1. With the flowmeter housing installed, mount the sensing head to a rigid support structure.
2. Remove the sensing head fiberglass cover. With the outer gasket in place, bolt the sensing head to the housing.
3. Adjust the sensing head levelling hardware (provided) to establish level in both horizontal planes.

---

#### Note

Ensure that the structure used to support the base mount sensing head is capable of supporting the dynamic material impact forces as well as the static weight of the sensing head.

---

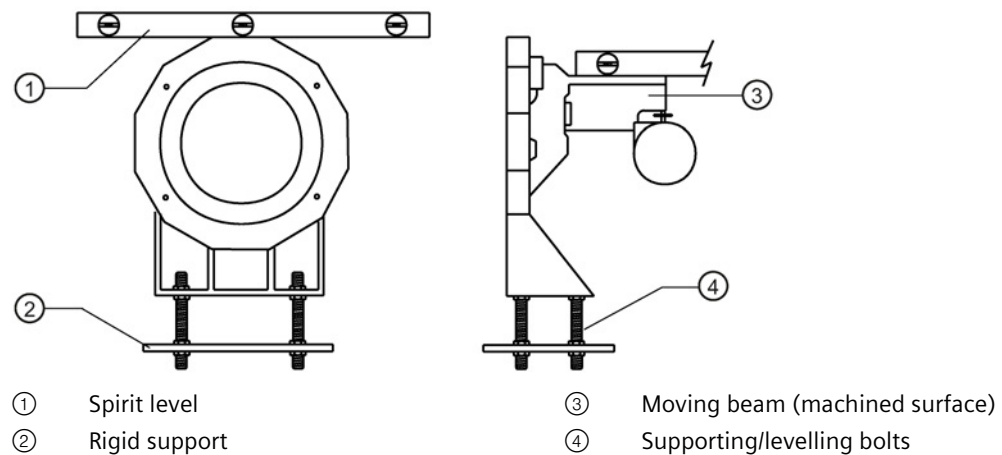

## 4.2 Sensing plate

1. Open the flowmeter housing access door.
2. Remove the sensing head cover and insert the sensing plate shaft fully into the sensing head shaft socket.

---

#### Note

Ensure that the slot in the end of the shaft mates with the roll pin in the back of the socket.

---

3. Tighten the set screw/hex screw to secure the sensing plate.

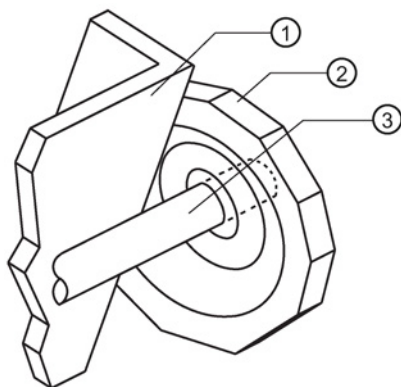

- ① Sensing plate
- ② Sensing head
- ③ Shaft

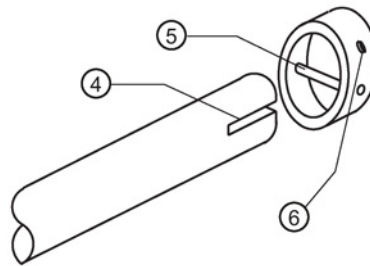

- ④ Slot
- ⑤ Roll pin
- ⑥ Set screw or hex head screw

### 4.3 Viscous damper

1. Remove the two damper cover shipping screws. The damper cover will be held up by a spring.
2. If necessary, top up the damper to near overflowing with the damping fluid supplied.
3. Store the damper cover shipping screws, remaining damper fluid, and filler bottle for future use.

**Note**

The damper must be full and free of air bubbles, with the damper cover in the UP position, during flowmeter operation.

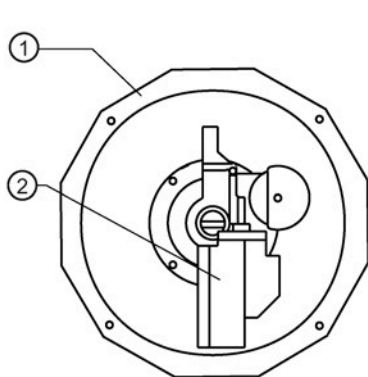

- ① Sensing head
- ② Damper
- ③ Filler bottle

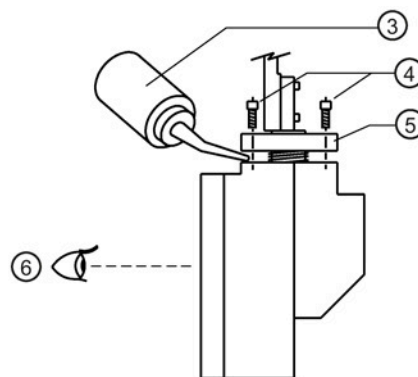

- ④ Shipping screws
- ⑤ Damper cover
- ⑥ Check that there are no bubbles

## Connecting

### 5.1 Unit without LVDT conditioner card

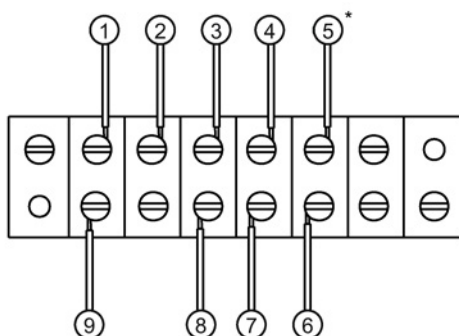

\* For Encapsulated LVDT (hazardous)

- YEL = WHITE
- BLU = ORANGE
- GRN = YELLOW

LVDT (Non-hazardous)	Integrator (LVDT connection)
① Green	⑨ SIG-
② Black	No connection
③ Yellow	⑧ COM
④ Blue	⑦ EXC-
⑤ Red	⑥ EXC+

#### Note

Ground shield at Integrator only.

## 5.2 Unit with sensing head mounted LVDT conditioner card

**Note**

Not applicable to Hazardous-rated units.

**LVDT to SF500 Integrator**

LVDT to LVDT conditioner card connections are made by Siemens.

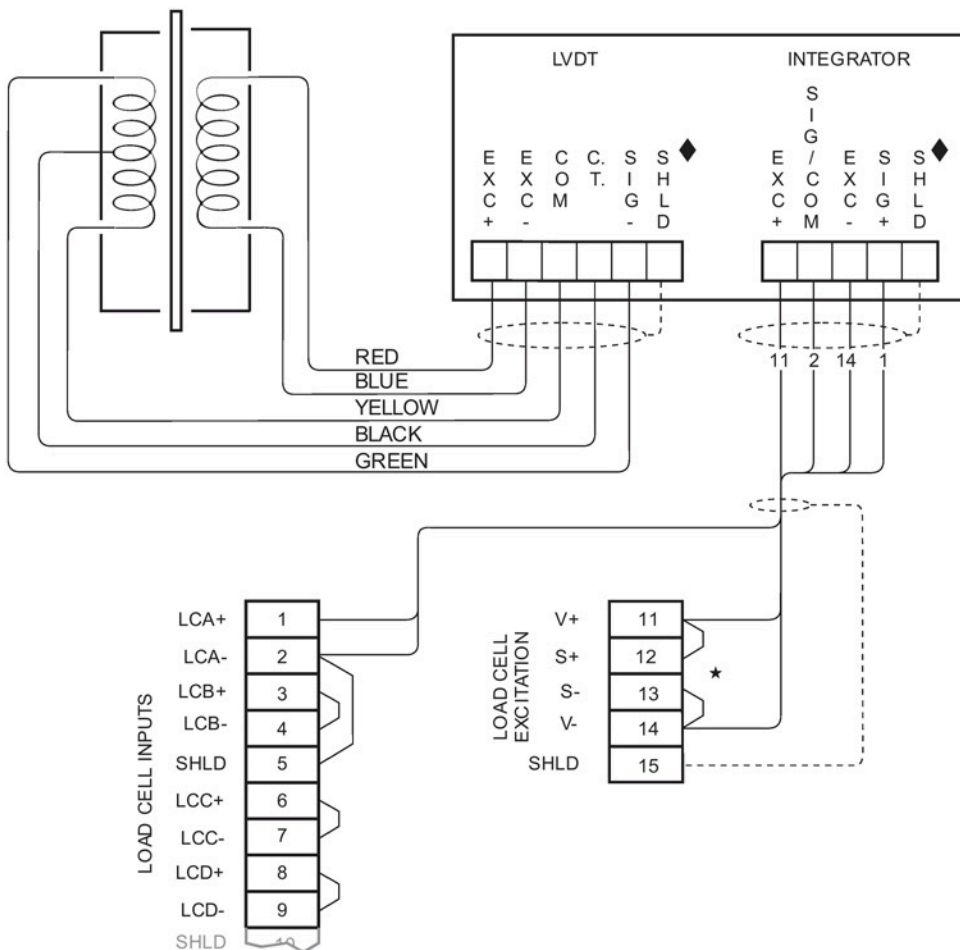

\*Where separation between the integrator and LVDT conditioner exceeds 150 m (500 ft):

1. Remove the jumpers from SF500 terminals 11/12 and 13/14.
2. Run additional conductors:
  - from SF500 terminal 12 to conditioner terminal block marked "Integrator EXC+"
  - from SF500 terminal 13 to conditioner terminal block marked "Integrator EXC-"

For further connection information on specific LVDTs, consult Siemens.



◆ Shields are common, but not grounded to chassis. Run cable shields through SHLD terminals and ground at Integrator only.

---

**Note**

Ensure that the connection between TB-2 and TB-17 is made.

---

**LVDT to SIWAREX FTC**

LVDT to LVDT conditioner card connections are made by Siemens.

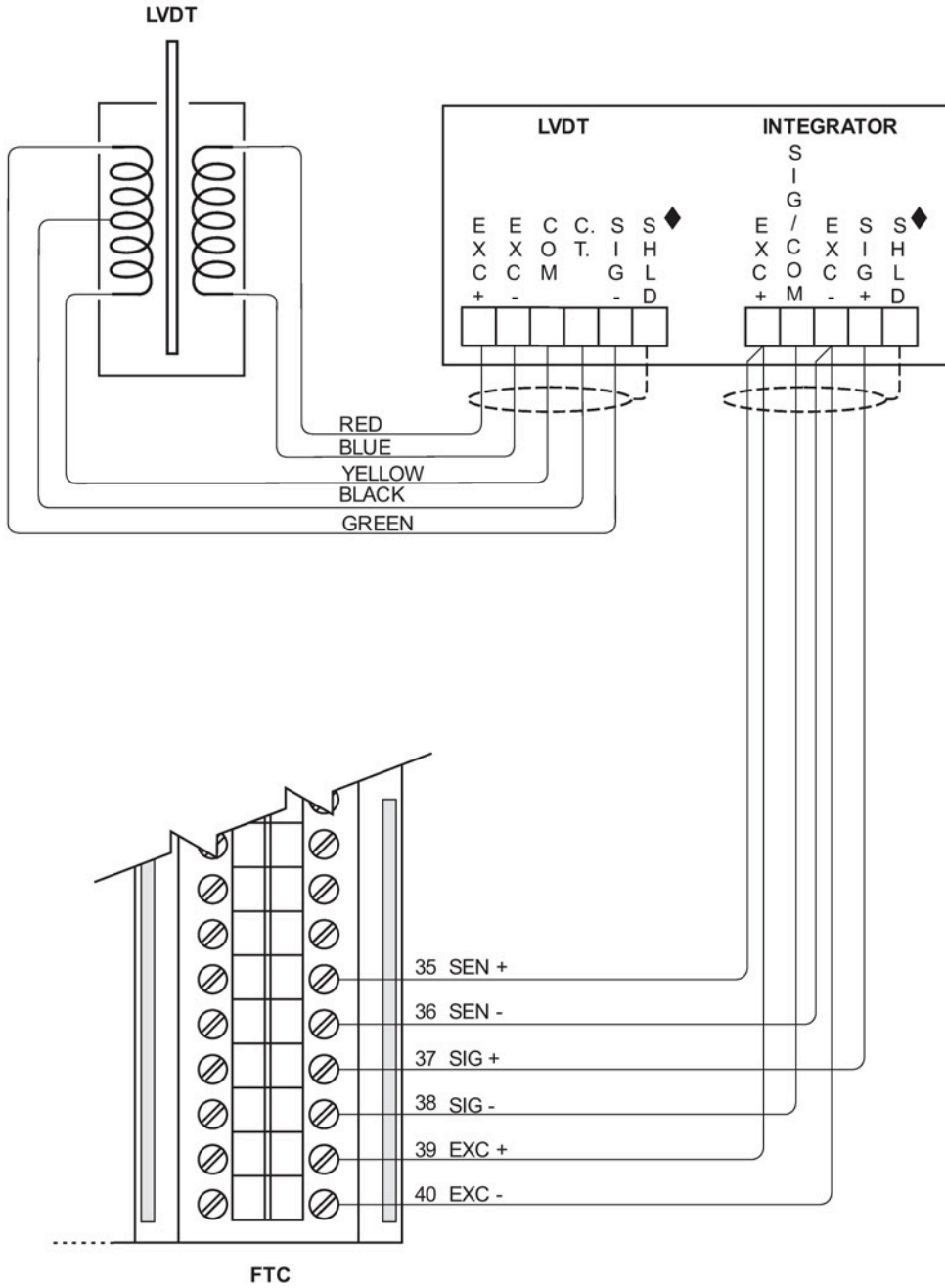

◆Connect the shield to the spring clamp shielding element that is mounted below the FTC. See FTC manual for details.

## 5.3 Unit with remote-located LVDT conditioner card

### LVDT to SF500 Integrator

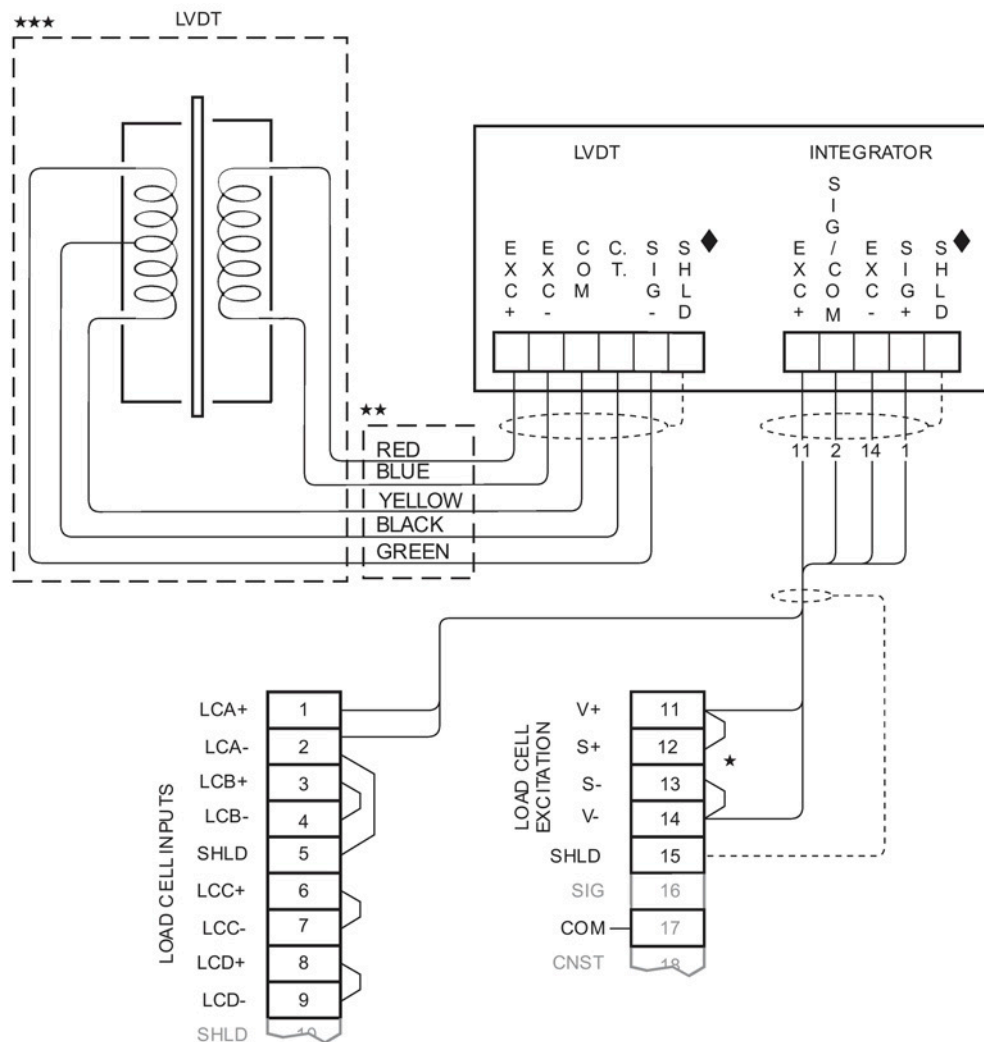

\*Where separation between the integrator and LVDT conditioner exceeds 150 m (500 ft):

1. Remove the jumpers from SF500 terminals 11/12 and 13/14
2. Run additional conductors:
  - from SF500 terminal 12 to conditioner terminal block marked "Integrator EXC+"
  - from SF500 terminal 13 to conditioner terminal block marked "Integrator EXC-"

For further connection information on specific LVDTs, consult Siemens.

\*\* For Encapsulated LVDT (hazardous)

- YEL = WHITE
- BLU = ORANGE
- BLK = Not connected
- BLU = ORANGE
- GRN = YELLOW

5.3 Unit with remote-located LVDT conditioner card

\*\*\*The LVDT can be installed in a hazardous area, but all other components must be in a non-hazardous area.

◆Shields are common, but not grounded to chassis. Run cable shields through SHLD terminals and ground at Integrator only.

---

**Note**

Ensure that the connection between TB-2 and TB-17 is made.

---

**Note**

Junction box included with hazardous-rated unit.

---

LVDT to SIWAREX FTC

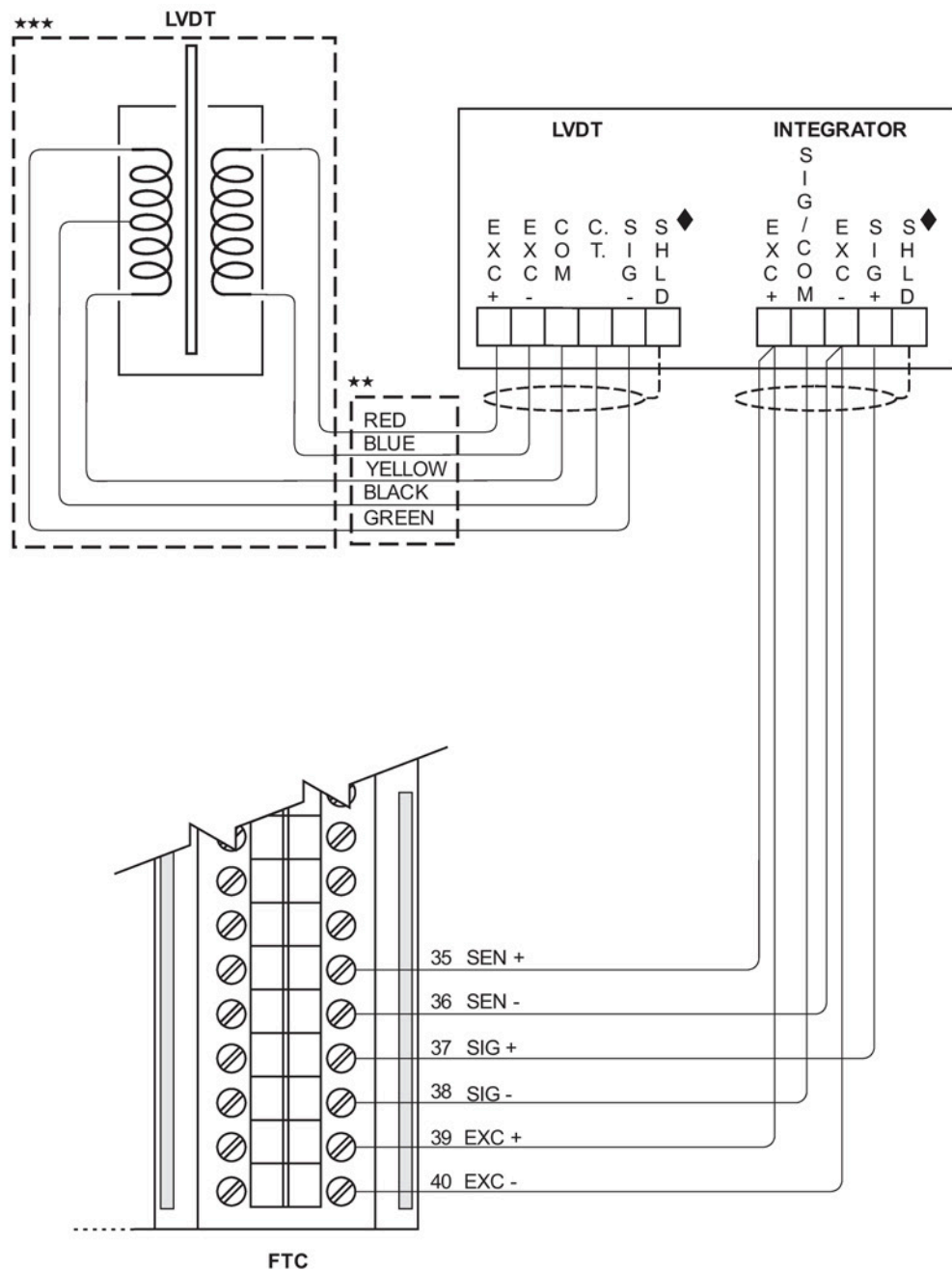

\*\* For Encapsulated LVDT (hazardous)

- YEL = WHITE
- BLU = ORANGE
- BLK = Not connected
- BLU = ORANGE
- GRN = YELLOW

\*\*\*The LVDT can be installed in a hazardous area, but all other components must be in a non-hazardous area.

5.3 Unit with remote-located LVDT conditioner card

◆Connect the shield to the spring clamp shielding element that is mounted below the FTC. See FTC manual for details.

---

**Note**

Junction box included with hazardous-rated unit.

---

## Commissioning

### 6.1 Calibration

A test weight is a calibration reference used to simulate a material impact force (test rate) on the flowmeter sensing plate during the integrator span calibration. The test weight is also used to perform a test to verify that the flowmeter sensing head is level.

The test rate should be 60 to 80% of the system design rate.

To determine the test rate produced by a specific test weight, calculate:

$$\text{Test Rate (TPH)} = \frac{\text{Test Weight (grams)}}{65^* \text{ grams/TPH}}$$

Alternatively, to determine the test weight required for a specific test rate, calculate:

$$\text{Test Weight (grams)} = \frac{65^* \text{ grams}}{1 \text{ TPH}} \times \text{Test Rate (TPH)}$$

---

#### Note

\*For WF350 flowmeters, use 80 grams (instead of 65 grams) when calculating Test Rate or Test Weight.

---

### Example

If the test weight used with a WF330 flowmeter is 500 grams:

$$\begin{aligned} \text{Test Rate} &= \frac{500 \text{ grams}}{65 \text{ grams/TPH}} \\ &= 7.69 \text{ TPH} \end{aligned}$$

---

#### Note

Use metric tons per hour (t/h) or short tons per hour (STPH) as applicable for TPH.

---

## 6.2 LVDT Output

### Zero adjustment (if required)

1. Connect a voltmeter across the LVDT green and yellow (or yellow and white; hazardous LVDT) wires.
2. With no load applied to the sensing plate, observe the V AC reading on the voltmeter.
3. If the LVDT output is  $0.10 \pm 0.05$  V AC, skip to Span Test, otherwise, proceed as follows:
  - Loosen the locknut on the LVDT threaded core.
  - Turn the core in/out of the LVDT until  $0.10 \pm 0.05$  V AC is obtained.
  - Tighten the locknut, ensuring the measured value is maintained.

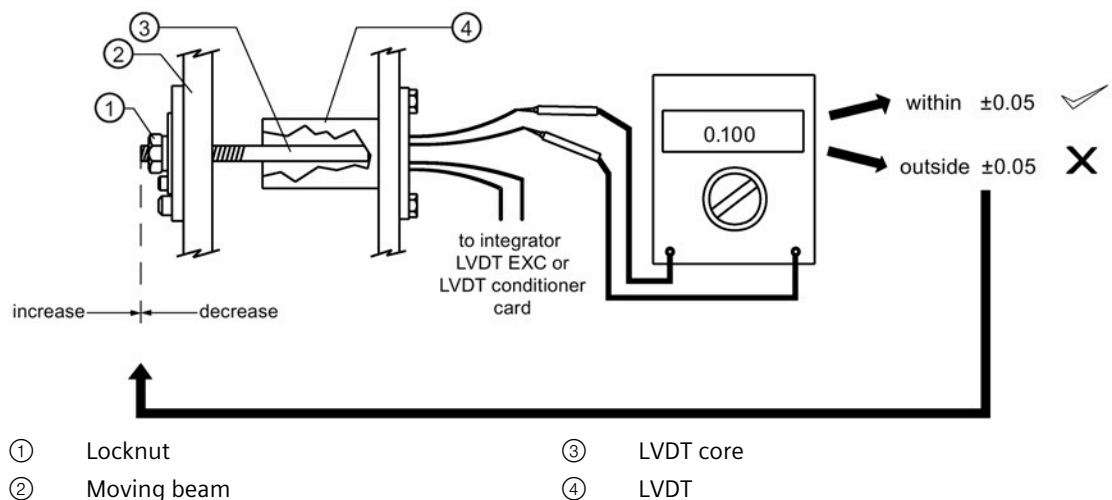

### Note

Ensure the new position of the LVDT core allows free movement within the LVDT bore.



## 6.3 Span test

1. Gently push the sensing head moving beam to the right. The LVDT output should steadily increase until a level of 0.75 to 1.0 V AC is achieved.
2. Gently push the sensing head moving beam to the left. The LVDT output should steadily decrease until zero is reached and then start increasing again to 0.015 to 0.5 V AC.
3. Ensure the LVDT output always returns to  $0.10 \pm 0.05$  V AC, (to the right hand side of zero) when pressure on the moving beam is released.

---

### Note

The LVDT core must not contact the inside of the LVDT over the range of core travel. The actual LVDT core travel during this procedure is less than 3 mm (1/8").

---

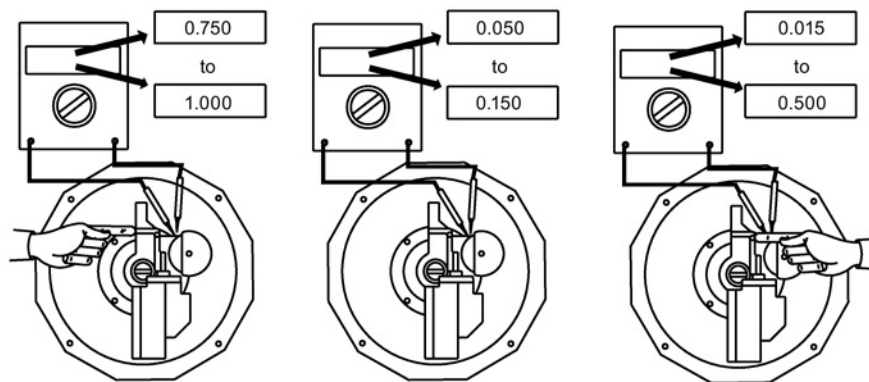

## 6.4 Sensing head level test

1. With the voltmeter still connected to the LVDT output, hang the test weight directly off the sensing plate.
2. Check to ensure that the LVDT output does not change by more than 0.01 V AC.

---

### Note

#### If the change is greater than 0.01 V AC:

1. Adjust the sensing head level, [refer to Sensing head (Page 12) ] until the change with and without the test weight on the sensing plate is less than 0.01 V AC.
  2. Remove the test weight and readjust the LVDT Output Zero, if necessary. If the level test is performed after the integrator has been calibrated, a new integrator zero and span calibration, span adjust, and factoring, should be performed.
-

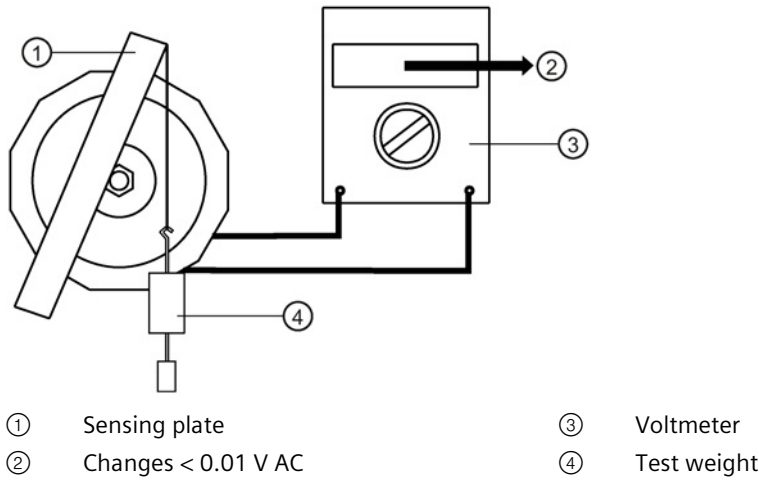

## 6.5 Integrator calibration

Refer to the Integrator operating instructions for integrator calibration instructions.

## 6.6 Zero calibration

Refer to the Integrator operating instructions for zero calibration instructions.

## 6.7 Span calibration

After a successful zero calibration, apply the test weight for the span calibration:

1. Attach one end of a string (monofilament fishing line or fine flexible cable) to the test weight.
2. Route the other end of the string over the calibration pulley.
3. Attach the free end of the string to the string fixing bolt.

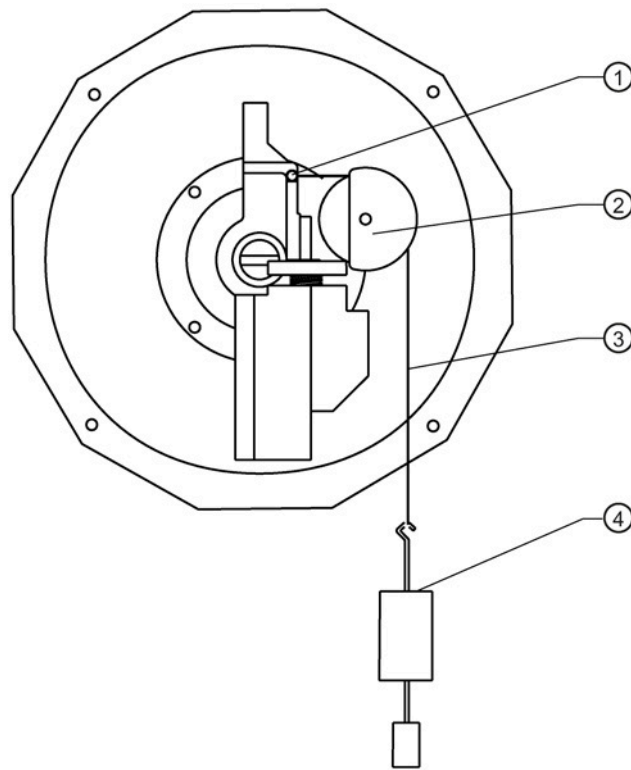

- |   |                    |   |             |
|---|--------------------|---|-------------|
| ① | String fixing bolt | ③ | String      |
| ② | Calibration pulley | ④ | Test weight |

---

**Note**

**Ensure that:**

- there is no material flow during zero and span calibrations
- the test weight is suspended free of any obstructions

Accurate calibration is not assured until material tests and a manual span adjustment have been performed, as outlined in the Integrator operating instructions.

---

## Service and maintenance

### 7.1 Maintenance

Establish a program of routine maintenance to ensure the highest achievable level of performance. Follow good housekeeping practices in the area of the flowmeter.

#### Typical maintenance program

Maintenance description	Frequency			
	Regular	Monthly	Semi-annual	Annual
Clean area around flowmeter	✓	✓	✓	✓
Check sensing plate surface <sup>1</sup>	✓	✓	✓	✓
Check damping fluid		✓	✓	✓
Check sensing head inner gasket		✓	✓	✓
Check sensing plate wear		✓	✓	✓
Check test weight Rate display			✓	✓
Test flowmeter linearity				✓

<sup>1</sup> Remove any material buildup in the impact area of the sensing plate.

### 7.2 Spare parts

Siemens recommends the following spare parts be kept on hand:

- sensing inner gasket
- sensing head outer gasket (base mount version only)
- damping fluid
- sensing plate

Contact Siemens or your distributor for spare parts ordering information. For a list of parts and part identification diagram, please see Appendix A (Page 38).

#### Unit repair and excluded liability

All changes and repairs must be done by qualified personnel and applicable safety regulations must be followed. Please note the following:

- The user is responsible for all changes and repairs made to the device.
- All new components must be provided by Siemens.
- Restrict repair to faulty components only.
- Do not re-use faulty components.

## **7.3 Inner gasket replacement**

Should it ever be necessary to replace the sensing head inner gasket, refer to the Sensing head (Page 12) and Dimension drawings (Page 36) sections of these operating instructions prior to performing the following procedure.

1. Remove the WFS300 fibreglass cover (4 bolts).
2. Bolt down the viscous damper cover to the shipping position (2 bolts).
3. Remove the sensing plate from the sensing head.
4. Remove the inner retaining ring (4 bolts).
5. a. Hazardous versions, remove the LVDT core and LVDT (3 bolts), or  
b. Non-hazardous, remove the LVDT cable TY WRAPs (2) and disconnect LVDT connections.
6. Remove the inner gasket.
7. Install the new inner gasket and reverse the procedure (steps 1 through 6).
8. Perform the LVDT output zero procedure.
9. Referring to the integrator operating instructions, perform an integrator zero and span calibration. Perform a span adjust if calibration accuracy appears affected.

# Diagnosing and troubleshooting

## 8.1 Range springs

The range spring establishes the range of sensing head moving beam travel for a given range of material flow. This spring is installed in the flowmeter sensing head at the factory. The spring is selected according to the specified design rate of the application.

For best operation, the range spring should provide 0.75 to 2.4 mm (0.030 to 0.094") of moving beam travel from the static zero to the design rate operation position. The moving beam travel may be inferred from the value of the LVDT output, as measured between the LVDT green and yellow wires (or yellow and white wires in the case of a hazardous-rated LVDT unit).

With the 2.5 V AC, 2.9 kHz LVDT excitation supplied:

- 0.75 mm of moving beam movement = 0.188 V AC
- 2.40 mm of moving beam movement = 0.600 V AC

Should the design rate of the flowmeter application change, it may be necessary to select and install another range spring to obtain the optimum moving beam travel (LVDT output) range.

### Range spring removal

1. Loosen the range spring locknut.
2. Remove the range spring mounting bolt and three flange mounting bolts.
3. Remove the range spring from the range spring assembly.

### Range spring replacement

1. Install the new range spring in the range spring assembly.
2. Mount the range spring assembly by the three flange mounting bolts.
3. With the moving beam in the static zero position, thread the range spring until the base just touches the static beam and then turn one complete revolution more.
4. Install the range spring mounting bolt and tighten the range spring locknut.

### Flowmeter recalibration

After you have removed and replaced the range spring, recalibrate the flowmeter and integrator. (See the Integrator operating instructions for details.)

1. Perform the LVDT output zero procedure.
2. Perform an integrator zero and span calibration.
3. Perform a span adjust and factoring as required.

## 8.2 Troubleshooting

Every SITRANS sensing head is subjected to extensive quality assurance procedures to ensure the highest possible degree of quality, reliability, and performance is achieved.

The following table indicates the probable cause, and proper course of action to be taken should the specified fault symptom occur.

Symptom	Cause	Action
Integrator rate display doesn't change when sensing plate is moved.	Wrong or bad integrator connection.	Refer to Connecting (Page 15).
	Viscous damper cover in shipping position.	Refer to Viscous damper (Page 14).
	Integrator not prepared for operation.	Program and calibrate the integrator.
Span adjustment does not have enough range.	Range spring not suited to application.	Refer to Range springs (Page 30).
Measurement results are not repeatable.	Sensing head not level.	Refer to Sensing head (Page 12) and Sensing head level test (Page 25).
	Moving beam travel is mechanically limited.	Ensure moving beam does not hit travel stops between -20% and 150% flowrates.
	Leaf springs are damaged.	Replace leaf springs, recalibrate flowmeter and integrator.
	Material flow patterns vary.	Refer to the Applications section of the flowmeter operating instructions
Accuracy varies with material flowrate.	Non-linear operation.	Refer to Linearity (Page 31).

## 8.3 Linearity

To test linearity, at least 3 test weights are used. Each weight represents a different test rate. Record the integrator rate display value associated with each test weight applied to the flowmeter.

If all the recorded display values are accurate, the flowmeter measurement is linear.

### Example

For a WF330 flowmeter design rate of 12 TPH, the following three test weights could be used:

- 780 g (1.72 lb) = 100% Design Rate = 12.0 TPH
- 585 g (1.29 lb) = 75% Design Rate = 9.0 TPH
- 390 g (0.86 lb) = 50% Design Rate = 6.0 TPH

### 8.3 Linearity

If non-linear results are obtained, ensure:

- at no flow, the moving beam does not rest on the zero stop bolt.
- at 150% Design Rate, the moving beam does not reach the full flow stop nut.
- at 150% Design Rate, the LVDT output does not exceed 1.0 V AC.
- the damper piston does not touch the damper cylinder wall at any flow rate.
- the LVDT core does not touch the inside of the LVDT at any flow rate.
- the viscous damper fluid is free of large air bubbles and the fluid level is correct.
- the range spring operates in compression from 0 - 100% flow rate.
- the sensing head leaf springs are in good condition.

If the test weight linearity test is successful, yet actual material test results are nonlinear, ensure there is no air circulation in the housing sensing plate area. If there is no significant air circulation in the flowmeter housing while you are running material, the material flow pattern is probably non-linear.

Non-linear material flow patterns can often be corrected by minor modifications to the material infeed, or upstream piping. Some integrators are equipped with a linearization function to compensate for non-linear material flow patterns. Stand-alone linearizing devices are also available for this purpose.

Electronic linearization should not be used to correct non-linear test weight results.



## Technical specifications

### 9.1 Performance

<b>Operating range</b>	minimum	0.2 t/h (0 to 0.2 STPH)
	maximum	40 t/h (0 to 44 STPH)
<b>Particle size</b>	fine powder to 13 mm (0.5")	
<b>Product temperature</b>	-40 to +232 °C (-40 to +450 °F)	
<b>Accuracy</b>	± 1 % of full scale, higher accuracy with linearizing function of integrator	
	Accuracy subject to: on factory approved installations the flowmeter system's totalized weight will be within the specified accuracy when compared to a known weighed material test sample. The test rate must be within the specified range of the design capacity and held constant for the duration of the test. The minimum material test sample must be equivalent to a sample obtained at the test flow rate for at least ten minutes running time.	
<b>Repeatability</b>	± 0.2 %	

### 9.2 Construction

<b>Construction</b>	dust-tight cast aluminum frame with fiberglass rear cover	
	<b>Option:</b> epoxy painted external aluminum casting surfaces	
<b>Mounting</b>	Side mount or base mount (to suit application)	
<b>Damping fluid</b>	1 - 100 cm <sup>2</sup> /s (100 - 10,000 cs) silicone (Dow Corning 200 recommended)	
<b>Enclosure</b>	IP64 (per IEC 60529)	
<b>LVDT conditioner card enclosure</b>	NEMA / Type 4 / IP65 (remote mounted unit)	
<b>Sensor type</b>	LVDT (linear variable differential transformer)	
<b>Sensing plate</b>	construction	304 (1.4306) stainless steel
		<b>Options</b> <ul style="list-style-type: none"> <li>• 316 (1.4404) stainless steel</li> <li>• abrasion resistant lining</li> <li>• PTFE coating for low cohesion and low friction</li> </ul>
<b>Cable</b> for connection between conditioner card and integrator	Belden®1 8404, 4 conductor, shielded 20 AWG (0.5mm <sup>2</sup> ) or equivalent	150 m (500 ft) maximum
	Belden 9260, 6 conductor <sup>2</sup> , shielded 20 AWG (0.5 mm <sup>2</sup> ) or equivalent	300 m (1000 ft) maximum

### 9.3 Input

<b>Cable</b> for connection between LVDT and LVDT conditioner card when remotely or integrator mounted	Belden 9260, 6 conductor, shielded 20 AWG (0.5 mm <sup>2</sup> ) or equivalent	300 m (1000 ft) maximum
---	--	-------------------------

- <sup>1</sup> Belden is a registered trademark of Belden Wire & Cable Company.
- <sup>2</sup> 6 conductor cable to be used with SIWAREX FTC.

## 9.3 Input

<b>Power</b> LVDT conditioner card	± 5 V DC (typically from a Siemens integrator)
<b>Input</b> LVDT conditioner card	0 to 0.75 V AC from LVDT

## 9.4 Output

<b>Output</b> LVDT conditioner card	0 to 50 mV DC to Siemens integrator; maximum 300 m (1000 ft) separation between conditioner card and integrator
<b>Output</b> LVDT	0 - 0.75 V AC @ 2.9 kHz
<b>LVDT excitation</b>	2.50 V AC @ 2.9 kHz (supplied by integrator or LVDT conditioner card)

## 9.5 Operating conditions

<b>Ambient temperature</b>	-40 to +60 °C (-40 to +140 °F)
	-40 to +50 °C (-40 to +122 °F) with optionally internally mounted LVDT card

## 9.6 Approvals

<b>Non-hazardous</b>	General purpose	CE, RCM	
<b>Hazardous</b>	Explosion-proof	FM/CSA Class I, Div. 1, Groups C, D Class II, Div. 1, Groups E, F, G Class III T6	US/Canada
	Non-Sparking/ Flame-proof	ATEX II 3G, Ex nA IIC T6 Gc ATEX II 2D, Ex tb IIIC T70°C Db IP64	Europe
		IECEX FMG 13.0016X, Ex nA IIC T6 Gc, Ex tb IIIC T70 °C Db IP64	International
	Non-Sparking/ Flame-proof	Ex tb IIIC T70°C Db X 2Ex nA IIC T6 GC X	Russia
<b>LVDT conditioner card approvals</b>	General purpose	CE, RCM	

## Dimension drawings

### 10.1 WFS300 side mount outline and mounting

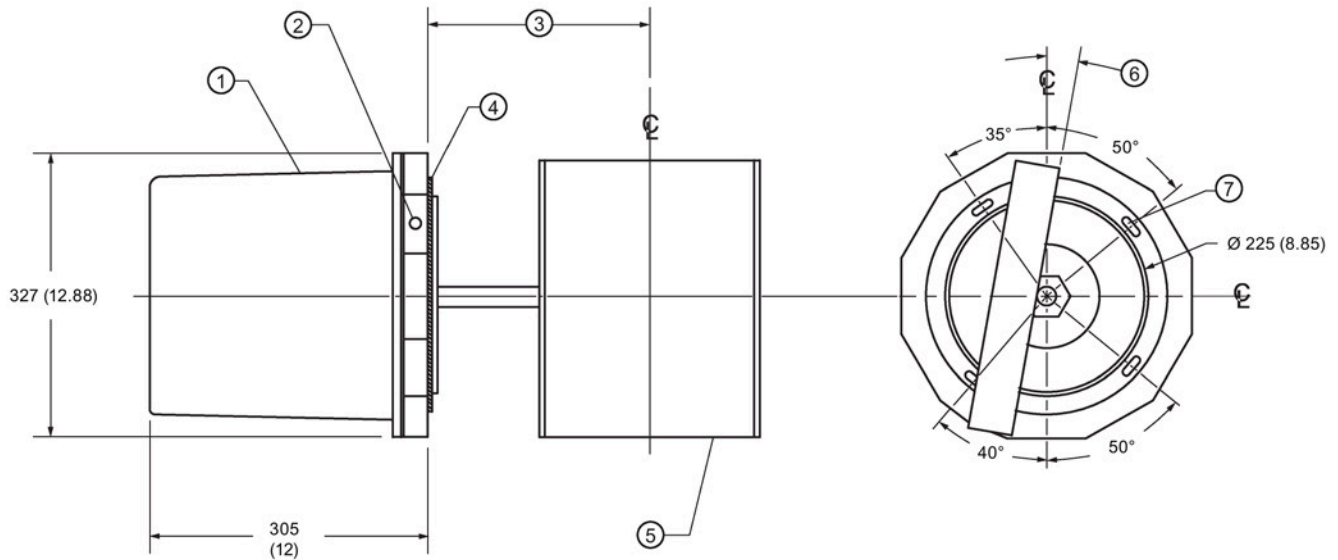

- |   |   |   |                    |
|---|---|---|--------------------|
| ① | Fiberglass cover  | ⑤ | Sensing plate      |
| ② | Conduit entry 1/2" NPT (internal)   | ⑥ | As required        |
| ③ | Refer to flowmeter drawing for the dimension from the sensing head mounting hole to the flowguide centerline. | ⑦ | 250 mm (9.84") BCD |
| ④ | Outer gasket  |   |                    |

---

#### Note

Ensure that the outer gasket seal to the flowmeter housing wall is dust tight.

---

## 10.2 WFS300 base mount outline and mounting

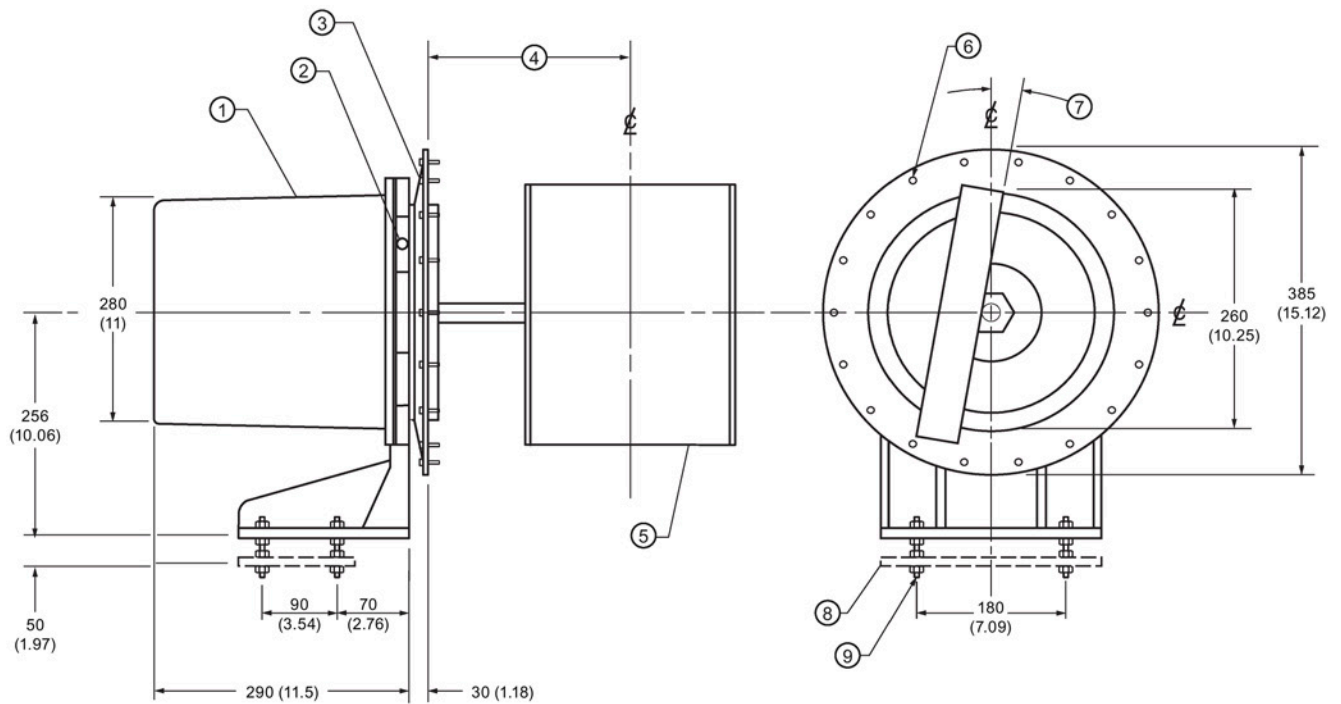

- |   |   |   |  |
|---|---|---|--|
| ① | Fiberglass cover  | ⑤ | Sensing plate                                      |
| ② | Conduit entry 1/2" NPT (internal)   | ⑥ | 8 mm (0.31") dia., 18 bolts on 360 mm (14.17") BCD |
| ③ | Outer gasket  | ⑦ | As required  |
| ④ | Refer to flowmeter drawing for the dimension from the sensing head mounting hole to the flowguide centerline. | ⑧ | Support plate (customer supplied)                  |
|   |   | ⑨ | 10 mm (0.38") dia. (4 leveling rods)               |

### Note

1. The sensing head support plate should be rigid and independent of the flowmeter housing.
2. Ensure that the outer gasket seal to the flowmeter housing wall is dust tight.

# Appendix A

# A

## A.1 WFS300 part identification diagram

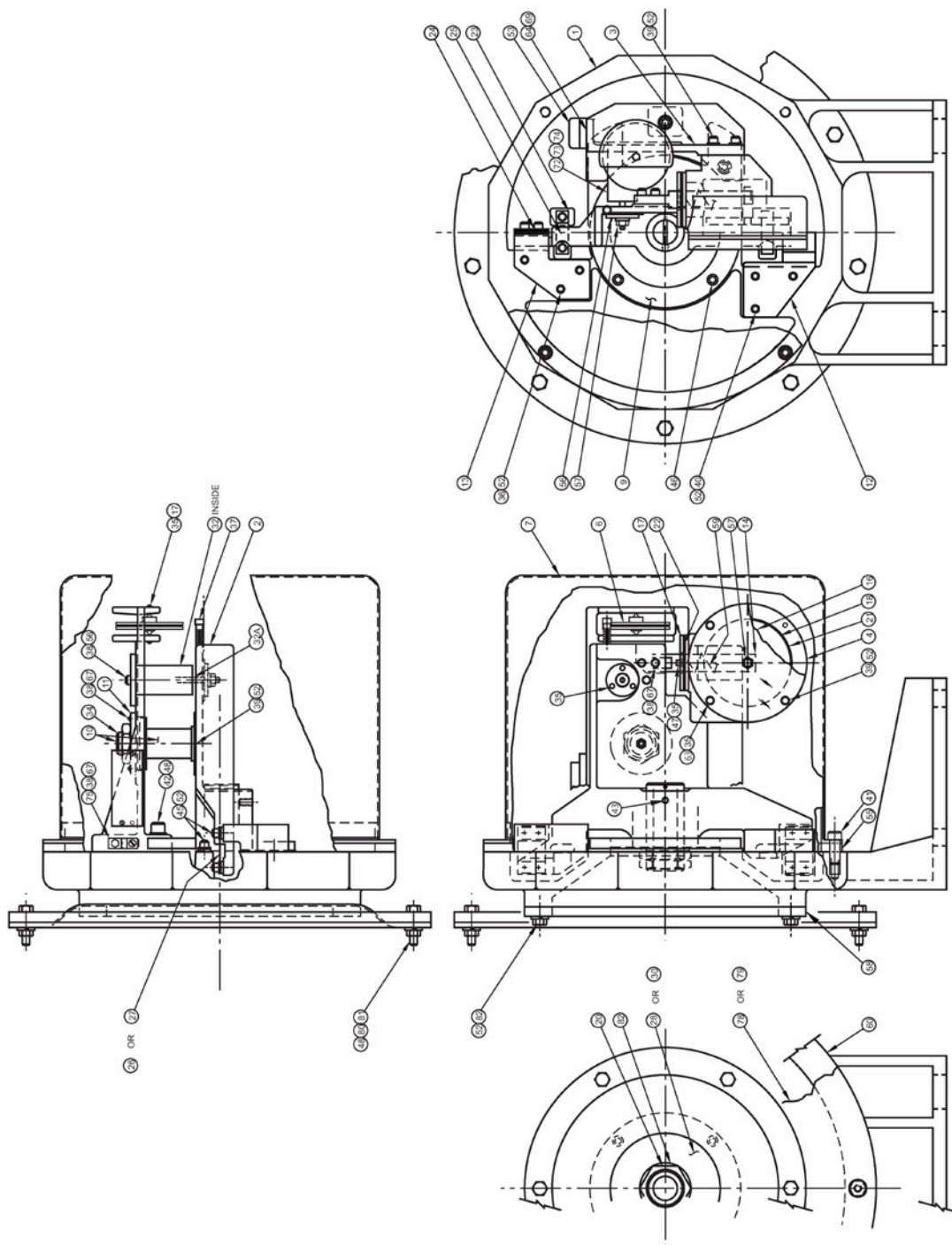

1	WFS300 body (cast frame) (side mount or base mount)	43	Set Screw (sensing plate) M6 x 20mm, stainless
2	Moving Beam (Dynamic Beam)	44	(not applicable)
3	Block (Static Beam)	45	Cap Screw M6 x 16 mm, stainless (12)
4	Block (Damper Body)	46	Cap Screw M6 x 12 mm, stainless (4)
5	(not applicable)	47	Lock Washer M4, stainless (2)
6	Calibrating Wheel	48	Lock Washer M8, stainless (3, add 18 for base mount)
7	Fiberglass Cover	49	(not applicable)
8	(not applicable)	50	(not applicable)
9	Inner Diaphragm Ring	51	(not applicable)
10	Range Spring	52	Lock Washer M6, stainless (24, add 6 for base mount)
11	Range Spring Adjustment Plate	53	Terminal Block (or 53A)
12	Lower Hinge Block	53A	LVDT Conditioner Card
13	Upper Hinge Block	54	(not applicable)
14	Damper Piston Rod	55	Edge Foam Seal
15	(not applicable)	56	Calibrating Flange
16	Damper Window	57	Nut M6, stainless (2)
17	Damper Cover	58	Inner Gasket Ring (base mount only)
18	Damper Piston	59	Damper Spring
19	(not applicable)	60	Outer Gasket Ring (base mount only)
20	Bushing Locknut (2)	61	(not applicable)
21	O-Ring, 3 1/4 x 3 1/2 x 1/8	62	Teflon Washer
22	O-Ring, 1 3/8 x 1 5/8 x 1/8	63	Nut M4, stainless (2)
23	Hinge Spring Spacer (8)	64	Split Lock Washer M3, stainless (2)
24	Hinge Spring Spacer (8)	65	(not applicable)
25	Hinge Spring, 0.3mm/25mm (2)	66	Washer M5, stainless (2)
26	Hinge Spring, 0.55mm/25mm (2)	67	Split Lock Washer M5, stainless (6)
27	Hinge Spring, 1.0mm/25mm (2)	68	(not applicable)
28	Diaphragm, silicone	69	Cap Screw M3 x 20 mm, stainless (2)
30	Diaphragm, neoprene	70	O-Ring, 7/16 x 5/8 x 3/32
31	(not applicable)	71	(not applicable)
32	LVDT (inside)	72	LVDT Housing
32	LVDT Core	73	LVDT Spring Washer
A			
33	Pivot Bearing (2)	74	LVDT retainer nut Diaphragm, silicone or neoprene
34	Lock Nut	75	Ground Lug
35	Cap Screw M4 x 12 mm, stainless (6)	76	(not applicable)
36	Cap Screw M6 x 40 mm, stainless (3)	77	Lock Nut, Pulley (2)
37	Cap Screw M4 x 30 mm, stainless (1)	78	Outer Gasket, silicone
38	Cap Screw M5 x 15 mm, stainless (10)	79	Outer Gasket, neoprene
39	Cap Screw M6 x 20 mm, stainless (7)	80	Cap Screw M8 x 35 mm, stainless (18) (base mount only)
40	Cap Screw M6 x 30 mm, stainless (3)	81	Nut M8, stainless (18) (base mount only)
41	Cap Screw M8 x 20 mm, stainless (4)	82	Cap Screw M6 x 25 mm, stainless (6) (base mount only)
42	Cap Screw M8 x 30 mm, stainless (3)		

# Product documentation and support

## B.1 Product documentation

Process instrumentation product documentation is available in the following formats:

- Certificates (<http://www.siemens.com/processinstrumentation/certificates>)
- Downloads (firmware, EDDs, software) (<http://www.siemens.com/processinstrumentation/downloads>)
- Catalog and catalog sheets (<http://www.siemens.com/processinstrumentation/catalogs>)
- Manuals (<http://www.siemens.com/processinstrumentation/documentation>)

You have the option to show, open, save, or configure the manual.

- "Display": Open the manual in HTML5 format
- "Configure": Register and configure the documentation specific to your plant
- "Download": Open or save the manual in PDF format
- "Download as html5, only PC": Open or save the manual in the HTML5 view on your PC

You can also find manuals with the Mobile app at Industry Online Support (<https://support.industry.siemens.com/cs/ww/en/sc/2067>). Download the app to your mobile device and scan the device QR code.

### Product documentation by serial number

Using the PIA Life Cycle Portal, you can access the serial number-specific product information including technical specifications, spare parts, calibration data, or factory certificates.

#### Entering a serial number

1. Open the PIA Life Cycle Portal (<https://www.pia-portal.automation.siemens.com>).
2. Select the desired language.
3. Enter the serial number of your device. The product documentation relevant for your device is displayed and can be downloaded.

To display factory certificates, if available, log in to the PIA Life Cycle Portal using your login or register.

#### Scanning a QR code

1. Scan the QR code on your device with a mobile device.
2. Click "PIA Portal".

To display factory certificates, if available, log in to the PIA Life Cycle Portal using your login or register.



## B.2 Technical support

### Technical support

If this documentation does not completely answer your technical questions, you can enter a Support Request (<http://www.siemens.com/automation/support-request>).

For help creating a support request, view this video here ([www.siemens.com/opensr](http://www.siemens.com/opensr)).

Additional information on our technical support can be found at Technical Support (<http://www.siemens.com/automation/csi/service>).

### Service & support on the Internet

In addition to our technical support, Siemens offers comprehensive online services at Service & Support (<http://www.siemens.com/automation/serviceandsupport>).

### Contact

If you have further questions about the device, contact your local Siemens representative at Personal Contact (<http://www.automation.siemens.com/partner>).

To find the contact for your product, go to "all products and branches" and select "Products & Services > Industrial automation > Process instrumentation".

Contact address for business unit:

Siemens AG  
Digital Industries  
Process Automation  
Östliche Rheinbrückenstr. 50  
76187 Karlsruhe, Germany

# Index

## C

- Catalog
  - catalog sheets, 40
- Certificates, 40
- Customer Support, (Refer to Technical support)

## D

- Downloads, 40

## H

- Hotline, (Refer to Support request)

## M

- Manuals, 40

## S

- Service, 41
- Service and support
  - Internet, 41
- Support, 41
- Support request, 41

## T

- Technical support, 41
  - partner, 41
  - personal contact, 41