

▼ De izquierda a derecha: RR10013, RR1502, RR20013, RR1010, RR7513



- Las roscas del collar y del émbolo, así como los orificios de montaje en la base facilitan la fijación de accesorios (en la mayoría de los modelos)
- Acabado de esmalte horneado para una mayor resistencia a la corrosión
- Silletas templadas desmontables para proteger al émbolo durante el levantamiento de peso y prensado
- La válvula de seguridad incorporada evita que se produzca una sobrepresión por accidente
- Todos los modelos incluyen los acoples CR400
- Diafragma limpiador del émbolo que reduce la contaminación y prolonga la vida útil del cilindro

## Los cilindros de rendimiento más versátil

Lo suficientemente resistentes como para funcionar en los lugares de trabajo más exigentes. Su diseño de precisión permite emplearlos en aplicaciones industriales de ciclos de alta frecuencia.



### Silletas

Los cilindros de la serie RR de hasta 75 toneladas vienen provistos con roscas en el émbolo para instalar las silletas inclinables de la **serie CATS**.

Las silletas inclinables están sujetadas al vástago, permitiendo el uso horizontal o hacia abajo.

Página: 41



### Rendimiento óptimo

La gama de bombas eléctricas **Z-Class** de Enerpac, equipadas con válvulas de 4 vías manuales u operadas por solenoide, ofrecen combinaciones óptimas con cilindros RR.

Página: 104

▼ Estos cilindros RR de carrera larga se acoplan a un sistema de guía y deslizamiento tirando del montaje de techo en arco del Estadio Olímpico de Atenas paso a paso hasta su posición final.



▼ Los cilindros RR brindan potencia y precisión en una prensa hidráulica especial.



# Cilindros de carrera larga de doble acción



## Selección de bombas

Los cilindros de doble acción deben accionarse mediante bombas con válvula de 4 vías.

Página: 139

## ▼ TABLA DE SELECCIÓN RÁPIDA

Para obtener la información técnica completa, vea la página siguiente.

Capacidad del cilindro (toneladas)	Carrera (pulg)	Número de modelo	Área efectiva del cilindro		Volumen de aceite		Altura retraído (pulg)
			(pulg <sup>2</sup> )		(pulg <sup>3</sup> )		
			Empujar	Tirar	Empuje	Tirar	
10	10.00	RR1010*	2.23	0.80	22.33	8.00	16.13
	12.00	RR1012*	2.23	0.80	26.80	9.00	18.00
30	8.25	RR308*	6.51	3.00	53.67	25.00	15.50
	14.50	RR3014*	6.51	3.00	92.70	43.00	21.63
50	6.13	RR506	11.06	3.40	67.77	21.00	13.06
	13.13	RR5013	11.06	3.40	145.17	44.00	20.06
	20.13	RR5020	11.06	3.40	222.56	68.00	28.88
75	6.13	RR756	15.92	4.90	97.58	29.00	13.69
	13.13	RR7513	15.92	4.90	209.00	64.00	20.69
100	6.63	RR1006	20.65	9.60	136.93	63.00	14.06
	13.13	RR10013	20.65	9.60	271.17	126.00	20.63
	18.13	RR10018	20.65	9.60	374.44	174.00	27.06
150	2.25	RR1502	30.71	14.80	69.11	33.00	7.19
	6.13	RR1506	30.71	14.80	188.28	91.00	15.19
	13.13	RR15013	30.71	14.80	403.27	194.00	22.20
	32.13	RR15032	30.71	14.80	986.84	475.00	43.94
200	6.00	RR2006	44.21	22.50	265.28	135.00	16.94
	13.00	RR20013	44.21	22.50	574.78	293.00	23.94
	18.00	RR20018	44.21	22.50	795.85	396.00	30.13
	24.00	RR20024	44.21	22.50	1,061	528.00	36.13
	36.00	RR20036	44.21	22.50	1,592	792.00	48.13
	48.00	RR20048	44.21	22.50	2,122	1,056	60.13
300	6.00	RR3006	70.93	38.00	425.56	228.00	19.13
	12.00	RR30012	70.93	38.00	851.12	456.00	25.13
	18.00	RR30018	70.93	38.00	1,277	684.00	31.13
	24.00	RR30024	70.93	38.00	1,702	912.00	37.13
	36.00	RR30036	70.93	38.00	2,553	1,368	49.13
	48.00	RR30048	70.93	38.00	3,405	1,824	61.13
400	6.00	RR4006	95.09	51.00	570.51	306.00	21.19
	12.00	RR40012	95.09	51.00	1,141	612.00	27.19
	18.00	RR40018	95.09	51.00	1,712	918.00	33.19
	24.00	RR40024	95.09	51.00	2,282	1,224	39.19
	36.00	RR40036	95.09	51.00	3,423	1,836	51.19
	48.00	RR40048	95.09	51.00	4,564	2,448	63.19
500	6.00	RR5006	113.15	63.00	678	378.00	22.75
	12.00	RR50012	113.15	63.00	1,358	756.00	28.75
	18.00	RR50018	113.15	63.00	2,037	1,134	34.75
	24.00	RR50024	113.15	63.00	2,716	1,512	40.75
	36.00	RR50036	113.15	63.00	4,074	2,264	52.75
	48.00	RR50048	113.15	63.00	5,431	3,024	64.75

## Serie RR



Capacidad:

**10 - 500 toneladas**

Carrera:

**2.25 - 48.00 pulgadas**

Presión de operación máxima:

**10,000 psi**



## Serie HCR de Enerpac

Si la aplicación no requiere ciclos de alta frecuencia, los cilindros de la serie HCR de Enerpac son la opción adecuada.

Página: 52



## Tabla de velocidades

Para determinar la velocidad aproximada de su cilindro, consulte la tabla de velocidades de los cilindros Enerpac en las "Páginas Amarillas".

Página: 409



## Silletas de encaje a presión opcionales

Silletas de encaje a presión opcionales para los cilindros de doble acción de la serie RR:

Tipo de silleta	Número de modelo del cilindro	Número de modelo de la silleta
Lisa	RR10	A102F
Inclinada	RR10	CATS12
	RR30	CATS52
	RR50, RR75	CATS100

## Silleta estándar

Acanalada	RR10	A102G
	RR30	A252G

Para obtener más información acerca de silletas:

Página: 10



Como consecuencia de ajustes de presión reducida en la válvula de alivio, la capacidad de retracción del cilindro para algunos cilindros RR puede ser menor que los valores teóricos:

RR308/3014: 4000 psi [276 bar]  
 RR506/5013/5020: 6950 psi [480 bar]  
 RR756/7513: 7200 psi [496 bar]

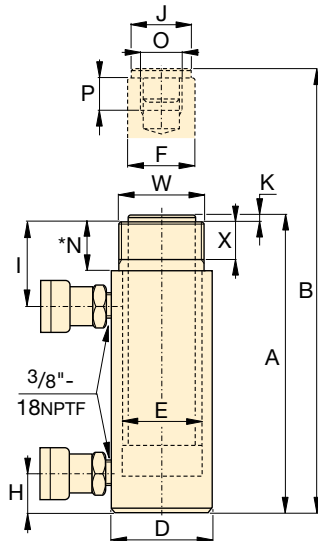

Modelos RR1010 al RR3014

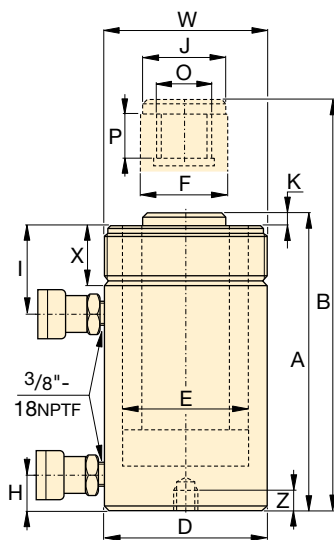

Modelos RR506 al RR50048

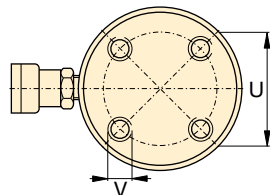

Modelos RR106 al RR30048

Sin agujeros de montaje:  
 RR506, 5013  
 RR756, 7513  
 RR1502, 15032

◀ Para conocer todas las características, consulte la página 41.

Capacidad nominal del cilindro (toneladas)	Carrera (pulg)	Número de modelo	Capacidad máxima del cilindro (toneladas)		Área efectiva del cilindro (pulg <sup>2</sup> )		Volumen de aceite (pulg <sup>3</sup> )		Altura retraído	Altura extendido	Ø externo
			Empuje	Tirar	Empuje	Tirar	Empuje	Tirar	A (pulg)	B (pulg)	D (pulg)
10	10.00	RR1010*	11.1	4.0	2.23	0.80	22.33	8.00	16.13	26.13	2.88
	12.00	RR1012*	11.1	4.0	2.23	0.80	26.80	9.00	18.00	30.00	2.88
30	8.25	RR308*	32.5	6.0	6.51	3.00	53.67	25.00	15.50	23.75	4.00
	14.50	RR3014*	32.5	6.0	6.51	3.00	92.70	43.00	21.63	36.13	4.00
50	6.13	RR506	55.3	11.8	11.06	3.40	67.77	21.00	13.06	19.19	5.00
	13.13	RR5013	55.3	11.8	11.06	3.40	145.17	44.00	20.06	33.19	5.00
	20.13	RR5020	55.3	11.8	11.06	3.40	222.56	68.00	28.88	49.00	5.00
75	6.13	RR756	79.6	17.6	15.92	4.90	97.58	29.00	13.69	19.81	5.75
	13.13	RR7513	79.6	17.6	15.92	4.90	209.00	64.00	20.69	33.81	5.75
100	6.63	RR1006	103.2	48.0	20.65	9.60	136.93	63.00	14.06	20.69	7.00
	13.13	RR10013	103.2	48.0	20.65	9.60	271.17	126.00	20.63	33.75	7.00
	18.13	RR10018	103.2	48.0	20.65	9.60	374.44	174.00	27.06	45.19	7.00
150	2.25	RR1502	153.5	74.0	30.71	14.80	69.11	33.00	7.19	9.44	8.00
	6.13	RR1506	153.5	74.0	30.71	14.80	188.28	91.00	15.19	21.31	8.00
	13.13	RR15013	153.5	74.0	30.71	14.80	403.27	194.00	22.20	35.31	8.00
	32.13	RR15032	153.5	74.0	30.71	14.80	986.84	475.00	43.94	76.06	8.00
200	6.00	RR2006	221.0	112.5	44.21	22.50	265.28	135.00	16.94	22.94	9.75
	13.00	RR20013	221.0	112.5	44.21	22.50	574.78	293.00	23.94	36.94	9.75
	18.00	RR20018	221.0	112.5	44.21	22.50	795.85	396.00	30.13	48.13	9.75
	24.00	RR20024	221.0	112.5	44.21	22.50	1,061	528.00	36.13	60.13	9.75
	36.00	RR20036	221.0	112.5	44.21	22.50	1,592	792.00	48.13	84.13	9.75
	48.00	RR20048	221.0	112.5	44.21	22.50	2,122	1,056	60.13	108.13	9.75
300	6.00	RR3006	354.6	190.0	70.93	38.00	425.56	228.00	19.13	25.13	12.25
	12.00	RR30012	354.6	190.0	70.93	38.00	851.12	456.00	25.13	37.13	12.25
	18.00	RR30018	354.6	190.0	70.93	38.00	1,277	684.00	31.13	49.13	12.25
	24.00	RR30024	354.6	190.0	70.93	38.00	1,702	912.00	37.13	61.13	12.25
	36.00	RR30036	354.6	190.0	70.93	38.00	2,553	1368	49.13	85.13	12.25
	48.00	RR30048	354.6	190.0	70.93	38.00	3,405	1824	61.13	109.13	12.25
400	6.00	RR4006	475.4	255.0	95.09	51.00	570.51	306.00	21.19	27.19	14.13
	12.00	RR40012	475.4	255.0	95.09	51.00	1,141	612.00	27.19	39.19	14.13
	18.00	RR40018	475.4	255.0	95.09	51.00	1,712	918.00	33.19	51.19	14.13
	24.00	RR40024	475.4	255.0	95.09	51.00	2,282	1224	39.19	63.19	14.13
	36.00	RR40036	475.4	255.0	95.09	51.00	3,423	1836	51.19	87.19	14.13
	48.00	RR40048	475.4	255.0	95.09	51.00	4,564	2448	63.19	111.19	14.13
500	6.00	RR5006	565.7	315.0	113.15	63.00	678.92	378.00	22.75	28.75	15.63
	12.00	RR50012	565.7	315.0	113.15	63.00	1,358	756.00	28.75	40.75	15.63
	18.00	RR50018	565.7	315.0	113.15	63.00	2,037	1134	34.75	52.75	15.63
	24.00	RR50024	565.7	315.0	113.15	63.00	2,716	1512	40.75	64.75	15.63
	36.00	RR50036	565.7	315.0	113.15	63.00	4,074	2268	52.75	88.75	15.63
	48.00	RR50048	565.7	315.0	113.15	63.00	5,431	3024	64.75	112.75	15.63

\*N: Para los modelos RR1010 y RR1012: N = 1.26 pulg.; para RR308 y RR3014: N = 2.20 pulg.

# Cilindros de doble efecto con carrera larga

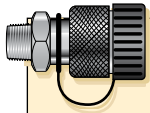

## Se incluyen los acoples

Todos los modelos incluyen los acoples CR400. Compatibles con todas las mangueras de la serie HC.

Capacidad:

**10 - 500 toneladas**

Carrera:

**2.25 - 48.00 pulgadas**

Presión de operación máxima:

**10,000 psi**

**Serie  
RR**



Ø interno del cilindro E (pulg)	Diám. del émbolo F (pulg)	Base a conexión de avance H (pulg)	Parte superior a conexión de ret. I (pulg)	Diám. de la silleta J (pulg)	Extensión de la silleta desde el émbolo K (pulg)	Rosca interna del émbolo O (pulg)	Longitud de la rosca del émbolo P (pulg)	Orificios de montaje en la base			Rosca del collar W (pulg)	Longitud de la rosca del collar X (pulg)	Peso (libras)	Número de modelo
								Circulo de pernos U (pulg)	Rosca V (pulg)	Prof. de la rosca Z (pulg)				
1.69	1.38	1.44	2.25	1.38	0.24	1-8	1.00	-	-	-	2¼-14	1.06	28	RR1010*
1.69	1.38	1.44	2.25	1.38	0.24	1-8	1.00	-	-	-	2¼-14	1.06	31	RR1012*
2.88	2.13	1.44	3.19	2.00	0.41	1½-16	1.00	-	-	-	3⅝-12	1.94	40	RR308*
2.88	2.13	1.56	3.19	2.00	0.41	1½-16	1.00	-	-	-	3⅝-12	1.94	64	RR3014*
3.75	3.13	1.13	3.00	2.81	0.11	1-12	1.00	-	-	-	5-12	2.00	67	RR506
3.75	3.13	1.13	3.00	2.81	0.11	1-12	1.00	-	-	-	5-12	2.00	115	RR5013
3.75	3.13	2.25	3.00	2.81	0.11	1-12	1.00	3.00	-	-	5-12	2.00	150	RR5020
4.50	3.75	1.19	3.00	2.81	0.25	1-12	1.50	-	-	-	5¾-12	1.50	92	RR756
4.50	3.75	1.19	3.19	2.81	0.25	1-12	1.50	-	-	-	5¾-12	1.50	150	RR7513
5.13	3.75	1.50	2.81	3.00	0.13	1¾-12	1.38	5.50	¾-10	1.00	6⅞-12	2.00	135	RR1006
5.13	3.75	1.50	2.81	3.00	0.13	1¾-12	1.38	5.50	¾-10	1.00	6⅞-12	2.00	205	RR10013
5.13	3.75	1.63	3.63	3.00	0.13	1¾-12	1.38	5.50	¾-10	1.00	6⅞-12	2.00	260	RR10018
6.25	4.50	0.88	2.63	3.67	0.06	-	-	-	-	-	-	-	110	RR1502
6.25	4.50	1.94	3.31	4.49	0.75	3⅝-16	1.38	6.25	¾-16	1.00	8-12	2.36	205	RR1506
6.25	4.50	1.94	3.31	4.49	0.75	3⅝-16	1.38	6.25	¾-16	1.00	8-12	2.36	275	RR15013
6.25	4.50	3.31	3.31	4.49	0.75	3⅝-16	1.38	-	-	-	8-12	2.36	525	RR15032
7.50	5.25	2.25	3.81	5.25	0.88	-	-	5.00	1-8	1.00	-	-	325	RR2006
7.50	5.25	2.25	3.81	5.25	0.88	2½-12	2.50	5.00	1-8	1.00	9¾-12	2.13	440	RR20013
7.50	5.25	3.38	4.00	5.25	0.88	2½-12	2.50	5.00	1-8	1.00	9¾-12	2.13	450	RR20018
7.50	5.25	3.38	4.00	5.25	0.88	2½-12	2.50	5.00	1-8	1.00	9¾-12	2.13	616	RR20024
7.50	5.25	3.38	4.00	5.25	0.88	2½-12	2.50	5.00	1-8	1.00	9¾-12	2.13	845	RR20036
7.50	5.25	3.38	4.00	5.25	0.88	2½-12	2.50	5.00	1-8	1.00	9¾-12	2.13	1065	RR20048
9.50	6.50	3.50	4.50	6.50	1.13	2½-12	3.25	6.25	1¼-7	1.75	12¼-12	2.31	441	RR3006
9.50	6.50	3.50	4.50	6.50	1.13	2½-12	3.25	6.25	1¼-7	1.75	12¼-12	2.31	608	RR30012
9.50	6.50	3.50	4.50	6.50	1.13	2½-12	3.25	6.25	1¼-7	1.75	12¼-12	2.31	776	RR30018
9.50	6.50	3.50	4.50	6.50	1.13	2½-12	3.25	6.25	1¼-7	1.75	12¼-12	2.31	1034	RR30024
9.50	6.50	3.50	4.50	6.50	1.13	2½-12	3.25	6.25	1¼-7	1.75	12¼-12	2.31	1385	RR30036
9.50	6.50	3.50	4.50	6.50	1.13	2½-12	3.25	6.25	1¼-7	1.75	12¼-12	2.31	1720	RR30048
11.00	7.50	4.25	5.25	7.50	1.13	3-12	3.75	8.00	1½-6	2.00	14⅞-8	2.56	670	RR4006
11.00	7.50	4.25	5.25	7.50	1.13	3-12	3.75	8.00	1½-6	2.00	14⅞-8	2.56	880	RR40012
11.00	7.50	4.25	5.25	7.50	1.13	3-12	3.75	8.00	1½-6	2.00	14⅞-8	2.56	1000	RR40018
11.00	7.50	4.25	5.25	7.50	1.13	3-12	3.75	8.00	1½-6	2.00	14⅞-8	2.56	1317	RR40024
11.00	7.50	4.25	5.25	7.50	1.13	3-12	3.75	8.00	1½-6	2.00	14⅞-8	2.56	1746	RR40036
11.00	7.50	4.25	5.25	7.50	1.13	3-12	3.75	8.00	1½-6	2.00	14⅞-8	2.56	2162	RR40048
12.00	8.00	4.75	6.00	8.00	1.13	3¼-12	4.25	8.00	1¾-5	2.12	15⅝-8	3.13	953	RR5006
12.00	8.00	4.75	6.00	8.00	1.13	3¼-12	4.25	8.00	1¾-5	2.12	15⅝-8	3.13	1300	RR50012
12.00	8.00	4.75	6.00	8.00	1.13	3¼-12	4.25	8.00	1¾-5	2.12	15⅝-8	3.13	1500	RR50018
12.00	8.00	4.75	6.00	8.00	1.13	3¼-12	4.25	8.00	1¾-5	2.12	15⅝-8	3.13	1800	RR50024
12.00	8.00	4.75	6.00	8.00	1.13	3¼-12	4.25	8.00	1¾-5	2.12	15⅝-8	3.13	2210	RR50036
12.00	8.00	4.75	6.00	8.00	1.13	3¼-12	4.25	8.00	1¾-5	2.12	15⅝-8	3.13	2700	RR50048