



Bypass Level Indicators Plastic Version



measuring
•
monitoring
•
analysing

NBK-16/-17

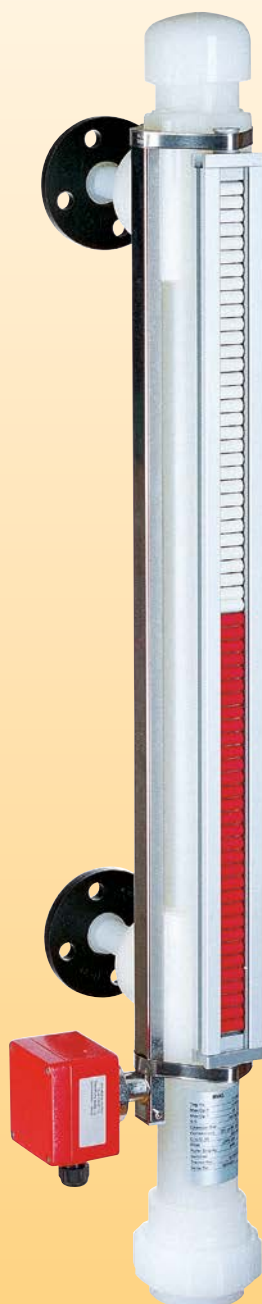

- Measuring length: max. 4000 mm
- p_{\max} : 4 bar; t_{\max} : 80 °C
- Viscosity: max. 200 mm²/s
- Connection:
DIN flange DN 20... 50
ANSI flange ¾" ... 2"
- Material: PP, PVDF
- Resistant to acids and alkali

N2



KOBOLD companies worldwide:

ARGENTINA, AUSTRIA, BELGIUM, BULGARIA, CANADA, CHILE, CHINA, COLOMBIA, CZECHIA, EGYPT, FRANCE, GERMANY, GREAT BRITAIN, HUNGARY, INDIA, INDONESIA, ITALY, MALAYSIA, MEXICO, NETHERLANDS, PERU, POLAND, REPUBLIC OF KOREA, ROMANIA, RUSSIA, SINGAPORE, SPAIN, SWITZERLAND, TAIWAN, THAILAND, TUNISIA, TURKEY, USA, VIETNAM

KOBOLD Messring GmbH
Nordring 22-24
D-65719 Hofheim/Ts.
Head Office:
+49(0)6192 299-0
+49(0)6192 23398
info.de@kobold.com
www.kobold.com



Description

Kobold plastic level indicators are used for continuous measurement, display and monitoring of liquid levels. The bypass tube is attached sideways to the wall of the vessel. According to the law of communicating tubes the level in the bypass tube equals the level in the vessel. A float with embedded circular magnets in the bypass tube follows the liquid level and transfers it in a non-contacting manner to a display fitted outside the tube or to a monitoring device. The following indication and monitoring devices are available:

Magnetic roller indicator

As the float passes by, the red/ white rollers are rotated in succession by 180° around their own axes. The rollers change from white to red as the level rises and from red to white as the level falls. The level is continuously displayed as a red column, even when the power fails.

Transmitter

To remotely transmit the level a transmitter with a chain of resistors can be mounted outside the bypass tube. A continuous standard signal of 4...20 mA is generated by means of a fitted transmitter. This standard signal can then be displayed with analogue or digital indicating devices.

Limit contacts

One or more reed contacts for limit-value acquisition or also for level control can be secured to the bypass tube.

Applications

- Storage tanks
- Aggressive media
- Mixing vessels
- Water tanks

Technical Data

Measuring length:	200...4000 mm
Bypass tube:	Ø 63 x 3 mm
Material:	PP or PVDF
Process connection (loose flange):	DIN flange according to DIN EN 1092-1 form B1 DN 20... DN 50, PN 10 ANSI flange B16.5 ¾"- 2", 150 lbs, RF
Operating pressure:	see table on following pages
Operating temperature:	PP: max. 60 °C PVDF: max. 80 °C
Min. density:	590 kg/m ³ (NBK-16) 790 kg/m ³ (NBK-17)
Seal:	O-ring, EPDM FPM, PTFE, FEP on request

Bypass pipe top:	pipe cap (dished boiler end DIN 2617)
Bypass pipe bottom:	threaded connection with drain screw, threaded connection with loose drain flange (without counter flange)
Overall length:	depending on measuring length, see dimension drawing
Installation position:	vertical

Roller indication:

Housing:	aluminium anodized
Indication rollers:	PBT red/white
Front cover:	Makrolon PC
Max. ambient temp.:	200 °C

Limit contacts (NBK-RPVC):

Housing:	Aluminium anodized
Contact function:	bistable changeover contact (reed contact)
Max. switch capacity:	230 V _{AC} , 60 VA, 1 A 230 V _{DC} , 30 W, 0,5 A
Cable:	1 m PVC (NBK-RPVC), 3 x 0.75 mm ²
Ambient temperature:	max. 90 °C
Protection:	IP 65

Reed contact resistor chain model ...W:

Housing:	Aluminium painted
Measuring principle:	Reed contact chain
Sensor tube:	stainless steel 1.4571
Total resistance:	3.2... 50 kΩ (depending on length)
Measuring-circuit voltage:	max. 24 V _{DC}
Measuring current:	max. 0.1 A
Resolution:	10 mm
Protection:	IP 65
Cable entry:	M20x1,5

Reed contact resistor chain with 2-wire transmitter model ...M:

Housing:	Aluminium painted
Output:	4... 20 mA
Supply voltage:	11... 30 V _{DC}
Max. load:	1000 Ω at U _B = 30 V _{DC} 700 Ω at U _B = 24 V _{DC} 50 Ω at U _B = 12 V _{DC}
Ambient temperature:	-20... +60 °C
Resolution:	10 mm
Protection:	IP 65
Cable entry:	M20x1,5



Order Details (Example: NBK-16 F 20 00 0 1 1)

Model ¹⁾	Material	Connection ²⁾	Nominal size	Roller indication	Transmitter	Media density / Float ³⁾ [kg/m ³]	Bypass pipe (bottom)
NBK-16..	PP	F = DIN flange A = ANSI flange	20 = DN 20, ¾"	00 = without RP = PBT rollers	0 = without W = Reed contact chain M = Reed contact chain with transmitter 4...20 mA 2-wire	1 = Nom. density 1320, Min. density 1200 2 = Nom. density 970, Min. density 910 3 = Nom. density 790, Min. density 750 4 = Nom. density 680, Min. density 660 5 = Nom. density 610, Min. density 590	1 = Threaded connection with drain screw G ½ 2 = Threaded connection with drain screw ½" NPT 3 = Threaded connection with drain flange DIN DN 15/ PN 16
NBK-17..	PVDF		25 = DN 25, 1" 32 = DN 32, 1¼" 40 = DN 40, 1½" 50 = DN 50, 2"			A = Nom. density 1480, Min. density 1340 B = Nom. density 1140, Min. density 1070 C = Nom. density 980, Min. density 930 D = Nom. density 890, Min. density 850 E = Nom. density 810, Min. density 790	
NBK-RPVC	Standard limit contact (bistable changeover contact), 1 m PVC cable						

¹⁾ Please specify in writing: measuring length 'L', medium density, operating pressure (max. 4 bar) and operating temperature

²⁾ Flange connection pressure rating standard is PN10. (PN16, PN25, PN40 on request)

³⁾ Tared /balanced float according to media density is optional available at extra charge. Float tare must be specified. Standard is without tare. Any deviation between media density and floats nominal density causes an additional error in measurement. Without float tare the minimum float density is stated on the instrument label.

Table: Classification acc. to PED 97/23/EG

Model	Total length L [mm]	P _{max} [bar]	Media (not dangerous) (diagram 2)	Media (dangerous) (diagram 1)
NBK-16, -17	<2100	4	Art. 3 §3	Art. 3 §3
	<4000	4	Art. 3 §3	-
	<4000	2,5	Art. 3 §3	Art. 3 §3

Media according to diagram 2 (not dangerous fluids) or diagram 1 (dangerous fluids) according to PED



Dimensions [mm]

Bypass Float

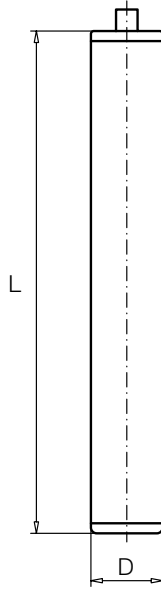

Model	Diameter D [mm]	Length L [mm]	Material
1	50	150	PP
2	50	200	PP
3	50	250	PP
4	50	300	PP
5	50	350	PP
A	50	150	PVDF
B	50	200	PVDF
C	50	250	PVDF
D	50	300	PVDF
E	50	350	PVDF

Dimensions [mm] (continuation)

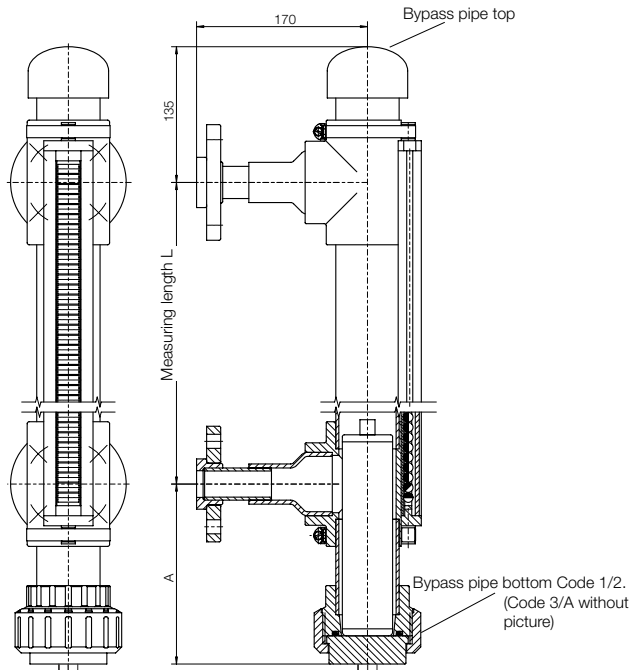

Reed contact chain

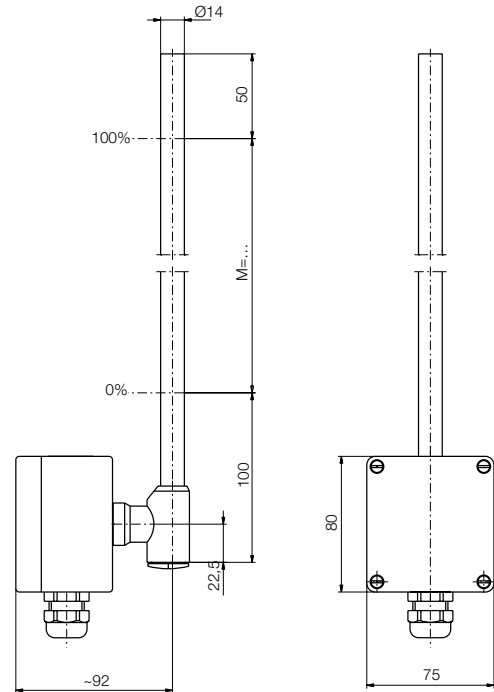

Clearance dimension A [mm]

Model	Material	Min. Medium densities				
		590 kg/m ³	660 kg/m ³	750 kg/m ³	910 kg/m ³	1200 kg/m ³
NBK-16	PP	320	270	220	170	170

Model	Material	Min. Medium densities				
		790 kg/m ³	850 kg/m ³	930 kg/m ³	1070 kg/m ³	1340 kg/m ³
NBK-17	PVDF	320	270	220	170	170

NBK-RPVC

