



Differential Pressure Transmitter



measuring
•
monitoring
•
analysing

PAD



- Span: 0.75 ... 15 mbar up to 4.137 ... 413.7 bar
- Static pressure: max. 310 bar
- t_{max} : +120 °C
- Process connection: 1/4" NPT, 1/2" NPT, various diaphragm seals on request
- Material: stainless steel, HAST-C, Tantalum, Monel
- Various output: 4 ... 20 mA, frequency output
- Sensor input: differential-, gauge-, absolute pressure
- Digital communication with HART® protocol
- ATEX-approval



P2

KOBOLD companies worldwide:

ARGENTINA, AUSTRALIA, AUSTRIA, BELGIUM, BULGARIA, CANADA, CHILE, CHINA, COLOMBIA, CZECHIA, EGYPT, FRANCE, GERMANY, GREAT BRITAIN, HUNGARY, INDIA, INDONESIA, ITALY, MALAYSIA, MEXICO, NETHERLANDS, PERU, POLAND, REPUBLIC OF KOREA, ROMANIA, SINGAPORE, SPAIN, SWITZERLAND, TAIWAN, THAILAND, TUNISIA, TURKEY, USA, VIETNAM

KOBOLD Messring GmbH
Nordring 22-24
D-65719 Hofheim/Ts.
Head Office:
+49(0)6192 299-0
+49(0)6192 23398
info.de@kobold.com
www.kobold.com



Description

The Kobold Differential Pressure Transmitter model PAD is a micro processor-based high performance transmitter, which has flexible pressure calibration and output, automatic compensation of ambient temperature and process variable, configuration of various parameters, communication with HART® protocol. The application is very various, as measuring pressure, flow and level by application method. All data of sensor is to be input, modified and stored in EEPROM.

As an option the Kobold Pressure Transmitter is also available as a flow meter. This flowmeter model PAD-F has added the totalizing function in the PAD transmitter. So it is available to check the flow rate and totalizing flow. It measures the flow rate by using differential pressure without compensation of temperature and static pressure. The shape of the PAD-F is the same as the standard device and it is only the terminal block which is different since there are two more terminals for the read-out of the pulse output.

Features

Superior performance

- High reference accuracy:
±0.075 % of calibrated span
(optional: ±0.04 % of calibrated span)
- Long-term stability (0.125 % URL for 3 years)
- High rangeability (100:1) for range 4-0

Flexibility

- Data configuration with HART® configurator
- Zero point adjustment

Reliability

- Continuous self-diagnostic function
- Automatic ambient temperature compensation
- EEPROM write protection
- Fail-mode process function
- CE EMC conformity standards (EN 50081-2, EN 50082-2)

Transmitter Description

Electronics module

The Electronics module consists of a circuit board sealed in an enclosure. There are a MCU module, an analog module, a LCD module and a terminal module in a transmitter. The MCU module acquires the digital value from the analog module and applies correction coefficients selected from EEPROM. The output section of the MCU module converts the digital signal to a 4...20 mA output. The MCU module communicates with the HART®-based configurator or control systems such as DCS. The Power section of MCU module has a DC-to-DC power conversion circuit and an input/output isolation circuit. The LCD module plugs into the MCU module and displays the digital output in a user-configured unit.

Functional Block Diagram

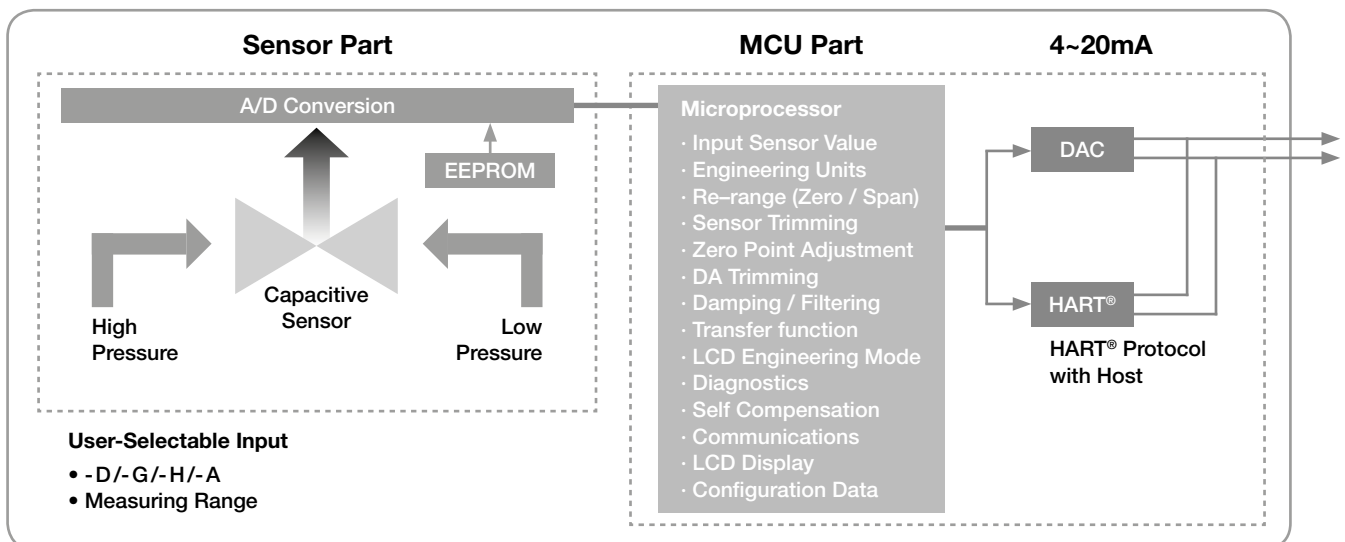

Sensor Inputs

The models PAD - D, - G, and - H are available in a differential pressure sensor of a capacitance type. The capacitance pressure sensor measures differential and gauge pressure and is commonly used in flow and level applications. Both sides in the capacitance sensor transmit process pressure from the process isolators to the sensor. The model PAD-A is also available in an absolute pressure sensor of a piezoresistive type and measures absolute pressure. The sensor module converts the capacitance or the resistance to the digital value. The MCU module calculates the process pressure based on the digital value.

The sensor modules include the following features

- 0.075 % accuracy
- The software of the transmitter compensates thermal effects, improving performance.
- Precise Input Compensation during operation is achieved with temperature and pressure correction coefficients that are characterized over the range of the transmitter and stored in the sensor module EEPROM memory.
- EEPROM stores sensor information and correction coefficients separately from MCU module, allowing an easy repair, reconfiguration and replacement.

Basic Setups

Following settings can be easily configured from any host that support the HART® protocol:

- Operational parameters
- 4-20 mA points (zero/span)
- Engineering units
- Damping time: 0.25...60 sec
- Tag: 8 alphanumeric characters
- Descriptor: 16 characters
- Message: 32 characters
- Date: day/month/year

Calibration and Trimming

- Lower/Upper range (zero/span)
- Sensor zero trimming
- Zero point adjustment
- DAC output trimming
- Transfer function
- Self-compensation

Self-diagnosis and others

- CPU & Analog Module Fault Detection
- Communication Error
- Fail-mode handling
- LCD indication
- Temperature measurement of sensor module



Multi Planar Process Connection

Conventionally, in the case where the pressure transmitter should be vertically installed irrespective of the orientation of the process connection lines, modified flanges (as shown above) are required in addition to the basic flanges. Multi-planar pressure transmitter have been made in an effort to solve the problems occurring in the related art, and an object of this multi planar is to provide a pressure transmitter, capable of being vertically installed without separate adaptor or various types of brackets regardless of the position of the process connection lines.

Process Connection via Diaphragm Seals

For the connection of the differential pressure transmitter model PAD to all different process connections, diverse diaphragm seal versions are necessary. They can be connected to the differential pressure transmitter by direct mounting or via a capillary tube. Depending on the application different combinations of diaphragm seals, capillary tubes and fill fluids are possible. To clarify those possibilities, the special connections via diaphragm seals are always to be requested separately to the differential pressure transmitter.



Technical Details

Measuring principle: Capacitance sensor (PAD-D, -F, -G, -H) Piezo-resistive (PAD-A)
Measuring span: 0.75...15 mbar up to 4.137...413.70 bar (depending on instrument version)
Accuracy: for range 2: ±0.25 % of span for 0.1 URL ≤ span ≤ URL
for range 3: ±0.075 % of span for 0.1 URL ≤ span ≤ URL
for range 4 to 0: ±0.075 % of span for 0.1 URL ≤ span ≤ URL
Turndown ratio: ranges 4 ~ 0 = 100:1
Process temperature: -40°C...+120°C
Ambient temperature: -30°C...+80°C
Ambient temperature effect: ± (0.019% URL + 0.125% span) / 28°C
Storage temperature: -40°C...+85°C (without condensing)
Humidity limit: 5 %...100 % RH

Pressure limits (with silicone oil)

(valid for stand-alone instruments only without assembled diaphragm seals)

Model D and G: 0...137.9 bar (for range 2...8)
Model G: 0...400 bar (for range 9)
Model H: 0...310 bar (for range 4...7)
Model A: 0...5 bar (for range 4)
0...30 bar (for range 5)
0...52 bar (for range 6)

Burst pressure

Model D, G and H: 689 bar
800 bar (for model G, range 0)
Model A: 10 bar (for range 4)
40 bar (for range 5)
70 bar (for range 6)

Wetted materials

Isolating diaphragms: 1.4404 (316L st. st), Monel, Tantalum, HAST-C

Drain/Vent valves: 1.4401 (316 st.st)
Flanges and adapters: 1.4401 (316 st.st)
O-ring: FPM, PTFE as an option

Non-wetted materials

Fill fluid: silicone oil or inert fill
Bolts: stainless steel
Electronics housing: aluminum, or 316L st.st. (option)
Cover o-ring: NBR
Paint: epoxy-polyester or polyurethane
Mounting bracket: for 2-inch pipe, 1.4301 (304 sst), with 1.4301(304 sst) U-bolt
Nameplate: 1.4301 (304 sst)
Process connections: 1/4" NPT with 54.0 mm centre distance for standard flanges
Mounting position: upright (process connection more flexible by using multi-planar flange)
Display: 5 Digit LCD
Power supply: 12...45 VDC -operation
Maximum load: 250 Ω at 17.5 VDC
Loop load: 0...1500 Ω - operation
Failure mode: fail high: current ≥ 21.1 mA
Electrical connection: 1/2" NPT conduit with M4 screw terminals
Output: two wire 4...20 mA, userconfigurable
Turn-On time: 3 seconds
Protection: IP 67 for Standard (code S)
Weight: 3.9 kg (excluding options) standard
ATEX approval: II 2G Exd IIC T6... T5 (option)



Order Details (Example: PAD-D EE 2 S 2 N S0 0)

Model	Version	Material Body/vent plug/ diaphragm	Calibrated span (Measuring range limits for PAD-D, -F, -G and -H in separate table)
PAD-	<p>D = differential pressure transmitter (static pressure 138 bar)</p> <p>F¹⁾ = differential pressure transmitter with pulse output and totalizer especially for flow measurement</p> <p>H = differential pressure transmitter for high line pressure (static pressure 310 bar)</p> <p>G = gauge pressure transmitter</p> <p>A = absolute pressure transmitter</p>	<p>EE = 316 st. steel/316 st. steel/316L st. steel</p> <p>EH = 316 st. steel /316 st. steel/ HAST-C</p> <p>EM = 316 st. steel/316 st. steel/ Monel</p> <p>ET = 316 st. steel /316 st. steel/ Tantalum</p>	<p>Calibrated span for PAD-D, -F, -G, -H</p> <p>2³⁾ = 0.75 ... 15 mbar</p> <p>3 = 1.5 ... 75 mbar</p> <p>4 = 3.73 ... 373 mbar</p> <p>5 = 18.65 mbar ... 1.865 bar</p> <p>6 = 69 mbar ... 6.9 bar</p> <p>7 = 206.8 mbar ... 20.68 bar</p> <p>8³⁾ = 689.5 mbar ... 68.95 bar</p> <p>9^{3) 4)} = 2.068 ... 206.80 bar</p> <p>0^{3) 4)} = 4.137 ... 413.70 bar</p> <p>Calibrated span for PAD-A</p> <p>4 = 25 mbar ... 2.5 bar</p> <p>5 = 150 mbar ... 15 bar</p> <p>6 = 250 mbar ... 25 bar</p>

Order Details (continued):

Filling liquid	Process connection	Electrical connection	Approvals for hazardous applications	Options
<p>S = silicone</p> <p>I = inert filling liquid</p>	<p>2 = 1/4" NPT female (standard)</p> <p>X²⁾ = special</p>	<p>N = 1/2" NPT epoxy-polyester painted aluminium</p> <p>G = G 1/2 epoxy-polyester painted aluminium</p> <p>X²⁾ = special</p>	<p>S0 = standard (waterproof IP67)</p> <p>F0 = ATEX, flameproof, Ex d</p>	<p>0 = without</p> <p>C = engineering unit (must be chosen when using the differential transmitter as a flowmeter)</p> <p>D = teflon o-ring (wetted part)</p> <p>E = oil free finish</p> <p>F = side vent / drain bottom</p> <p>G = side vent / drain top</p> <p>H = multi-planar process connection</p> <p>M = housing in stainless steel</p> <p>N⁵⁾ = mounting of PAD onto diaphragm seal</p> <p>Y²⁾ = special calibration range</p>

¹⁾ Specify flow rate engineering unit, Δ p and flow rate at URV (Upper Range Value), Δ p and flow rate (generally '0') at LRV (Lower Range Value)
pulse scale (choose only one value from 0.001, 0.01, 0.1, 1, 10, 100, 1000, 10000 m³/pulse) and pulse width (choose only one value from 10 ms, 50 ms, 100 ms), while ordering so that max. duty cycle is 49 pulses/sec

²⁾ Code X not available for ATEX. Order code X and Y must be specified in writing

³⁾ Not for PAD-H

⁴⁾ Not for PAD-D and PAD-F

⁵⁾ Diaphragm seal model and application data to be specified in clear text. Application Index on the last two pages of this data sheet to be filled out. For summary of diaphragm seal models and possible ranges, see following page 11 onwards. For dimensional details see DRM data sheet.

Order Details Oval flange adapter

Dimensions [mm]

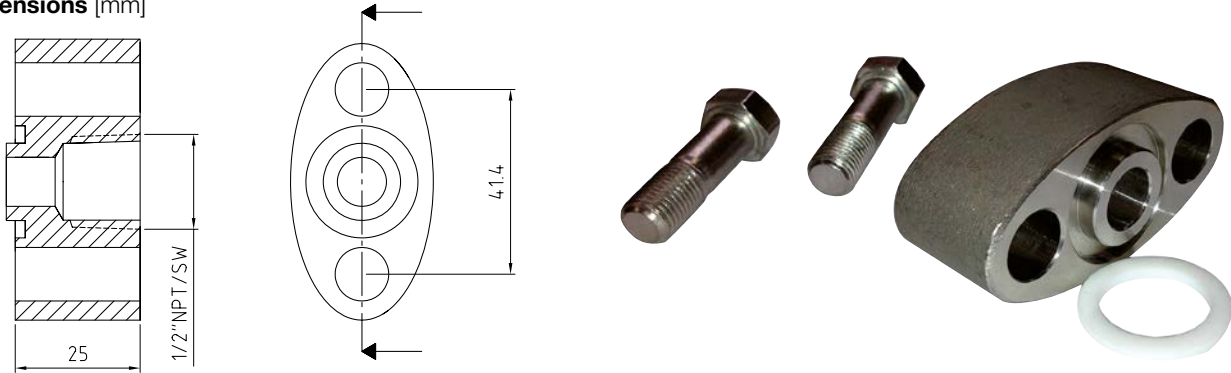

Technical Details

Material: 1.4401 (316 Stainless steel)

Seal: PTFE

Bolts: 2 x mounting screws UNF7/16-20

Process connection: 1/2" NPT female

Order code: ZUB-PAD-OVF

Order Details Mounting brackets

Description	Order code
Angle type bracket for PAD/PAS vertical pipe mounting for PAS vertical pipe mounting for PAD incl. U-Clamp for 2" pipe mounting bracket and 2 x mounting nuts/ washers incl. 4 x mounting screws for PAS incl. 4 x mounting screws for PAD	ZUB-PAD/PAS-K
Flat type bracket for PAD/PAS horizontal pipe mounting for PAS vertical pipe mounting for PAD incl. U-Clamp for 2" pipe mounting bracket and mounting nuts/ washers incl. 4 x mounting bolts and washers for PAS incl. 4 x mounting bolts for PAD	ZUB-PAD/PAS-L

Order Details Manifold valves

Description	Order code
3-way manifold valve, remote mount, machined	ZUB-PAD-3WMR
5-way manifold valve, remote mount, machined	ZUB-PAD-5WMR
2-way manifold valve, direct mount, machined	ZUB-PAD-2WMD
2-way compact manifold valve, direct mount, machined	V-2003CDADABAA
3-way compact manifold valve, direct mount, machined	V-3151CHHHIBAA
5-way compact manifold valve, direct mount, machined	V-5050CDAHIBAA
3-way manifold valve, direct mount, forged	V-3454CHHHBAA



Measuring Range Limits for PAD-D, -F, -G and -H

Range code	Calibrated span	Lower range limit (LRL)			Upper range limit (URL)
		PAD-D, -F	PAD-G	PAD-H	
2	0.75...15 mbar	- 15 mbar	- 15 mbar	-	15 mbar
3	1.5...75 mbar	-75 mbar	-75 mbar	-	75 mbar
4	3.73...373 mbar	-373 mbar	-373 mbar	-373 mbar	373 mbar
5	18.65 mbar...1.865 bar	-1.865 bar	-1 bar	-1.865 bar	1.865 bar
6	69 mbar...6.9 bar	-6.9 bar	-1 bar	-6.9 bar	6.9 bar
7	206.8 mbar...20.68 bar	-20.68 bar	-1 bar	-20.68 bar	20.68 bar
8	689.5 mbar ...68.95 bar	-68.95 bar	-1 bar	-	68.95 bar
9	2.068...206.80 bar	-	-1 bar	-	206.80 bar
0	4.137...413.70 bar	-	-1 bar	-	413.70 bar

* Special Measuring span with adequate lower and upper range limits on request

Unit Conversion

Range code	bar	kg/cm ²	KPa	psi	in H ₂ O at 4 °C	mm H ₂ O at 4 °C	in Hg at 0 °C
2	0.015	0.015	1.5	0.217	6	152	0.422
3	0.075	0.076	7.5	1.087	30	765	2.215
4	0.373	0.38	37.3	5.410	149	3804	11.014
5	1.865	1.902	186.5	27.049	749	19018	55.072
6	6.900	7.036	690	100.073	2773	70361	203.750
7	20.681	21.088	2068	299.930	8310	210878	610.660
8	68.950	70.309	6895	1000.009	27708	703097	2036.025
9	206.800	210.876	20680	2999.303	83105	2108781	6106.597
0	413.700	421.856	41370	6000.211	166085	4218566	12216.550



Dimensions [mm]
PAD standard*

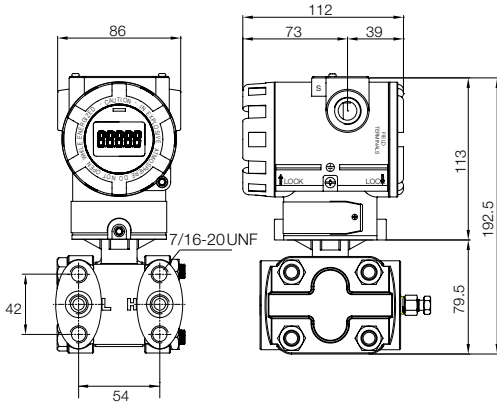

PAD multi planar process connection*

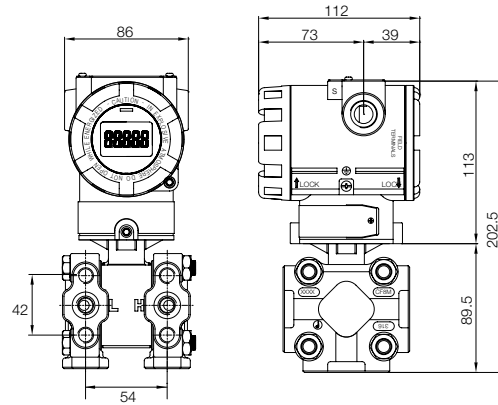

PAD with multi planar flange and angle type bracket*

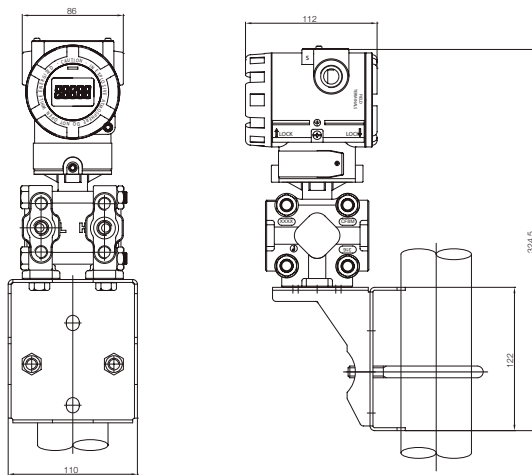

PAD standard with flat type bracket (vertical mounted)*

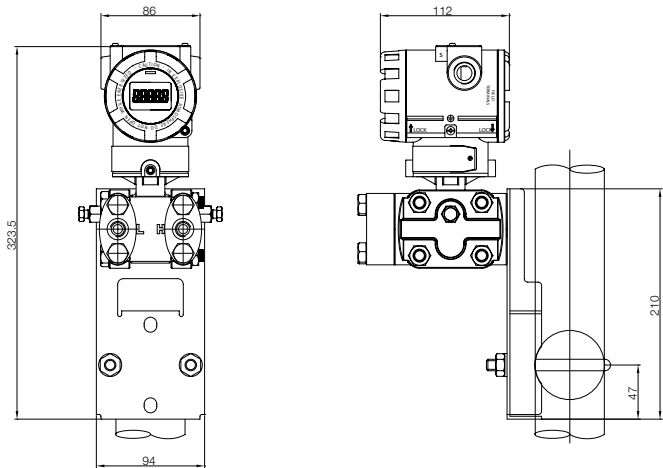

PAD standard with flat type bracket (horizontal mounted)*

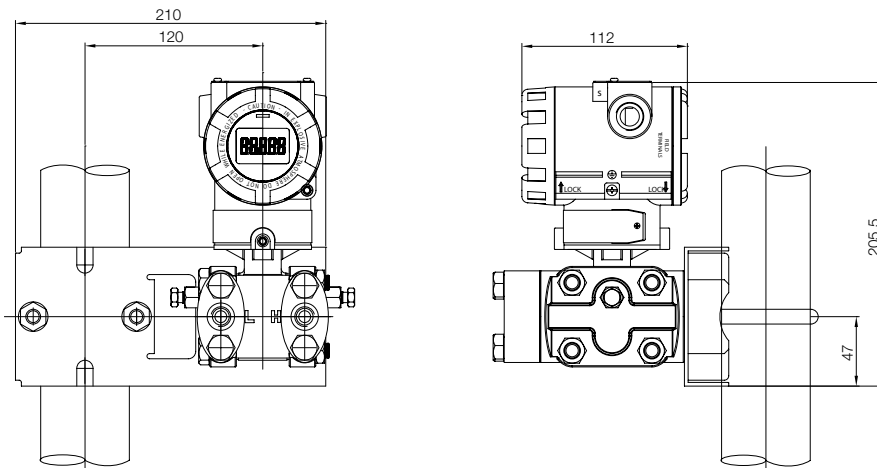

* For PAD-G/A, the low pressure port 'L' is always closed



PAD-G/A mounted with 2-way manifold valve*

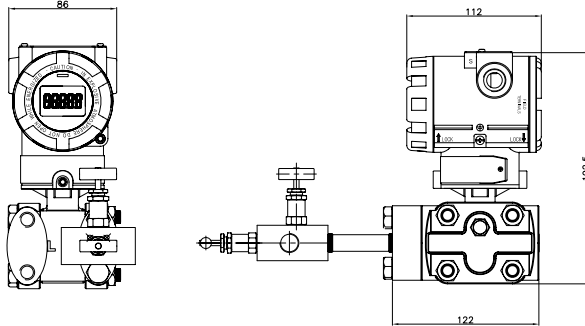

* For PAD-G/A, the low pressure port 'L' is always closed

Manifold valves (remote mount)

Technical Details

Material: 316SS body with PTFE packing
 Connection and size: 1/2" NPT (F)
 Pressure rating: 6000 psig at 38 °C (~410 bar)
 Temperature range: -54 °C ... +232 °C

3-way manifold valve

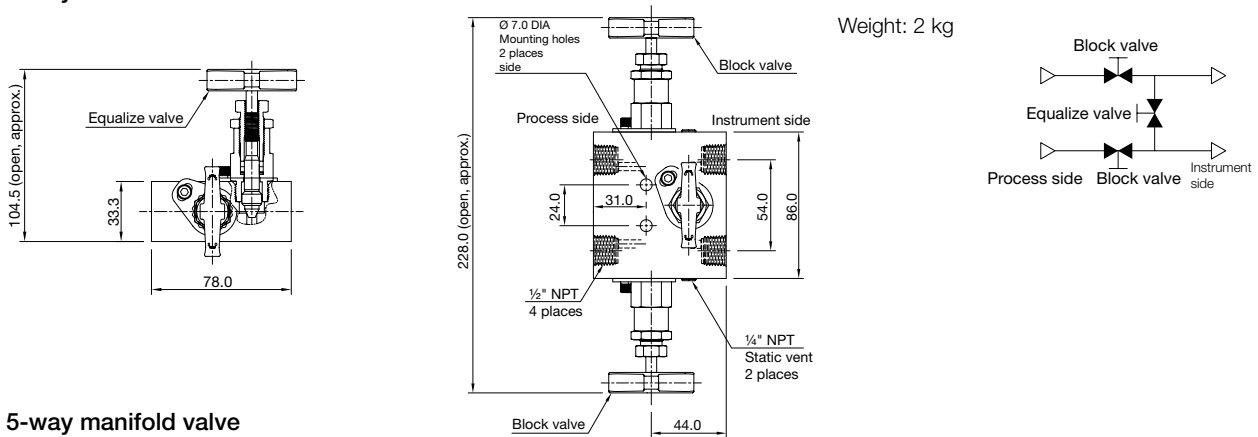

5-way manifold valve

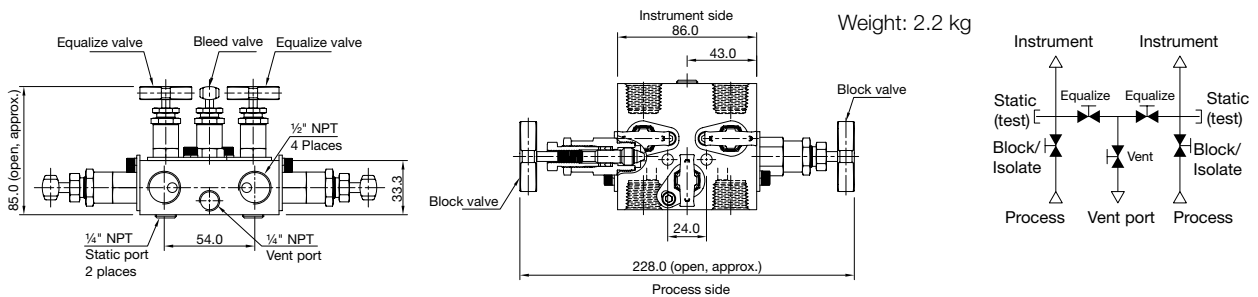



Manifold valves (Direct mount)

Technical Details

Material: 316SS body with PTFE packing
 Connection and size: 1/2" NPT (F) to flange

Pressure rating: 3 000 psig at 232 °C (≈210 bar)
 Temperature range: -54 °C ... +232 °C

2-way Manifold valve

Weight: 1.6 kg

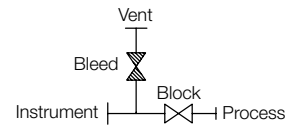
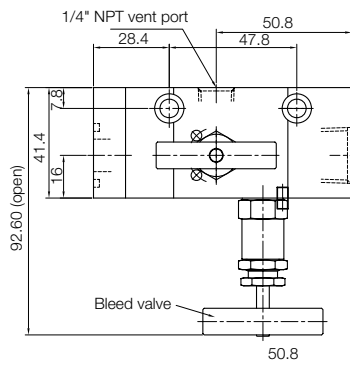
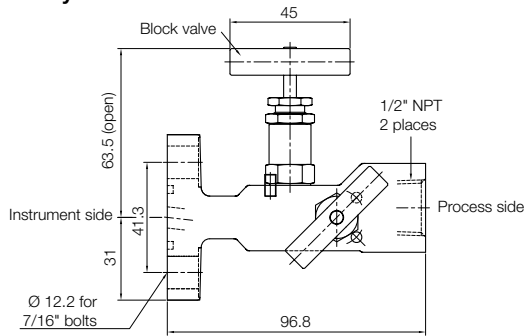

Manifold valves (Direct mount, machined)

Technical Details

Material: AISI 316L

Pressure rating: 6000 psi

Temperature range: -73°C ... +210°C (PTFE packing), standard

-54°C ... +510°C (GRAPHOIL packing), on request

Weight: 0.88 kg

2-way Manifold valve

(inlet: 1/2" NPT female/outlet: 1/2" NPT male)

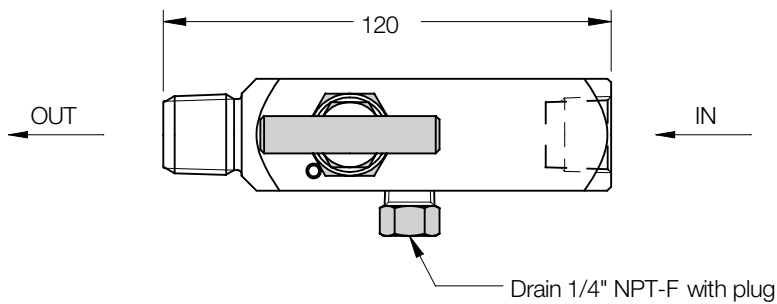
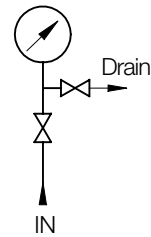
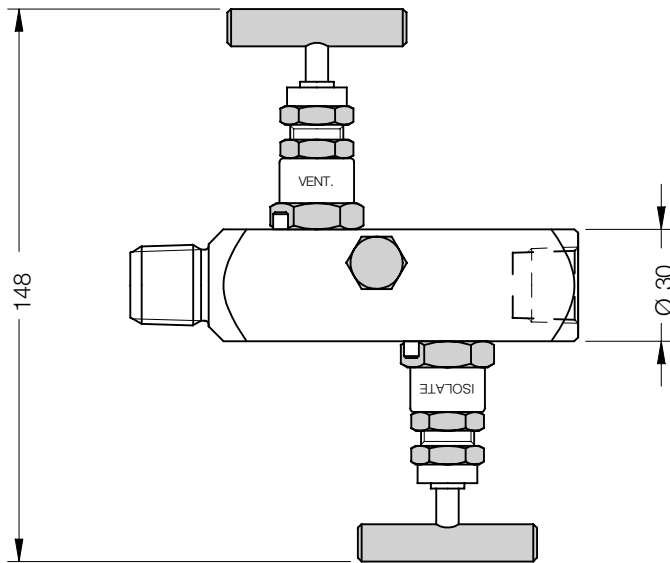

Included accessories

Plug

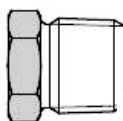

Order Code: V-2003CDADABAA (PTFE packing)

Typical bracket mounted installations with 5-way manifold valve (direct mounting)

5-way manifold valve at front and multi-planer process connection

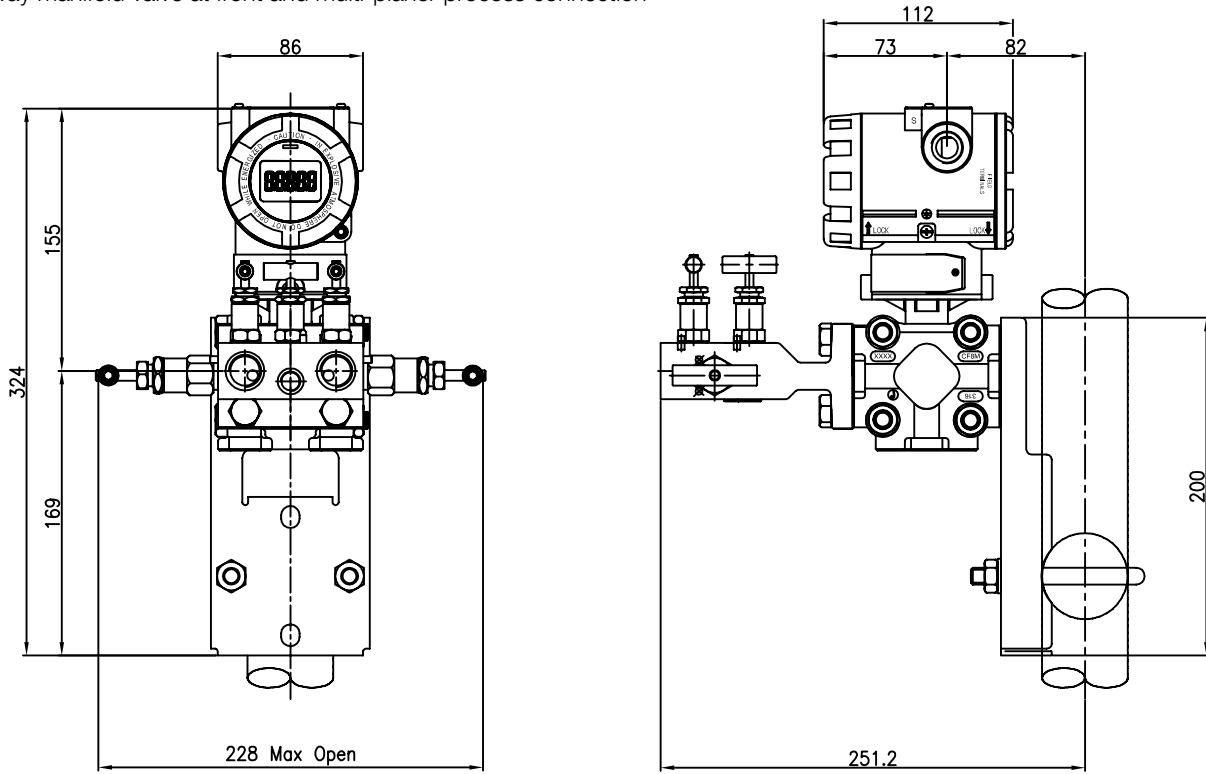

5-way manifold valve at bottom and multi-planer process connection

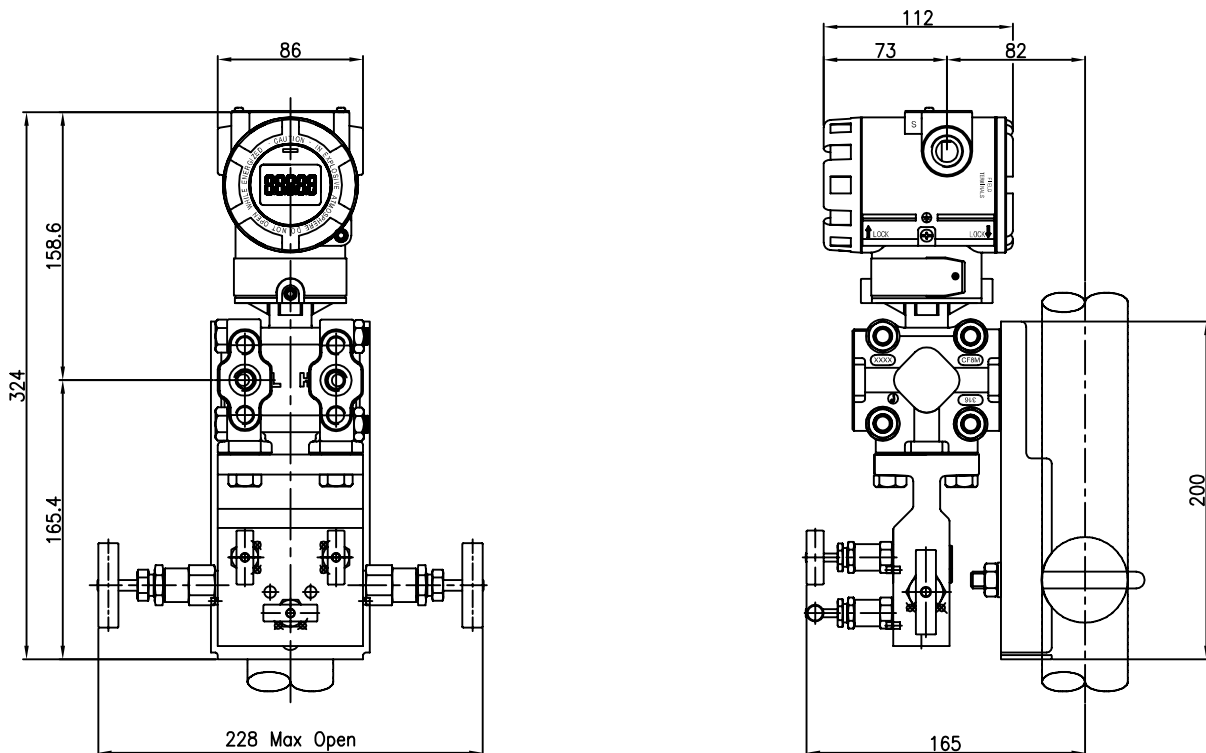



Manifold valves (Direct mount, machined)

Technical Details

Material: AISI 316L
 Pressure rating: 6000 psi
 Temperature range: -73°C... +210°C (PTFE packing), standard
 -54°C... +510°C (GRAPHOIL packing), on request

Weight: 2.17 kg

3-way Manifold valve

(inlet: flanged/outlet: flanged according to IEC 61518 Type A)

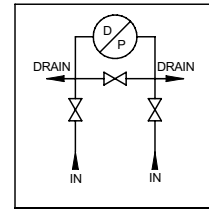
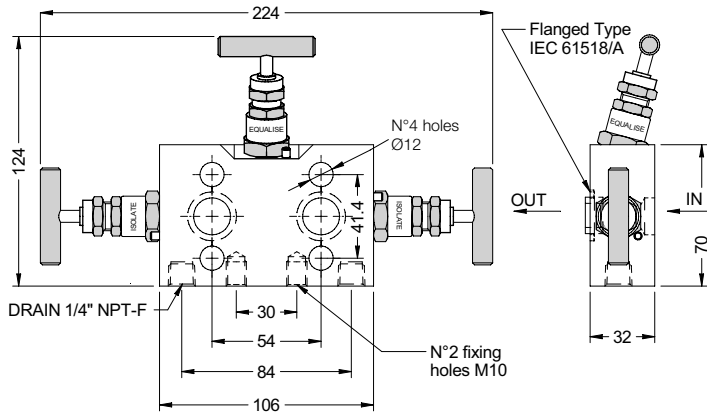

Included accessories:

- 4 carbon steel screws (stainless steel on request)
- 2 plugs
- 2 PTFE gaskets

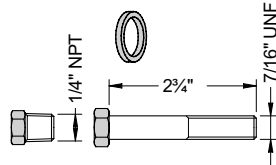

Order Code: V-3151CHHHIBAA (PTFE packing)

Possible ways of mounting 3-way manifold valve with PAD

Description	Process connection	Illustration
Valve mounted upside down on front side of PAD	Flanged according to IEC 61518 type A	
Valve mounted upside down on front side of PAD including oval flange adapter model ZUB-PAD-OVF	1/2" NPT female	
Valve mounted on front side of PAD, head of PAD rotated by 90° clockwise	Flanged according to IEC 61518 type A	
Valve mounted on front side of PAD including oval flange adapter model ZUB-PAD-OVF, head of PAD rotated by 90° clockwise	1/2" NPT female	



Manifold valves (Direct mount, machined)

Technical Details

Material: AISI 316L
 Pressure rating: 6000 psi
 Temperature range: -73°C...+210°C (PTFE packing), standard
 -54°C...+510°C (GRAPHOIL packing), on request

Weight: 2.80 kg

5-way Manifold valve

(inlet: 1/2" NPT/outlet: flanged according to IEC 61518 Type A)

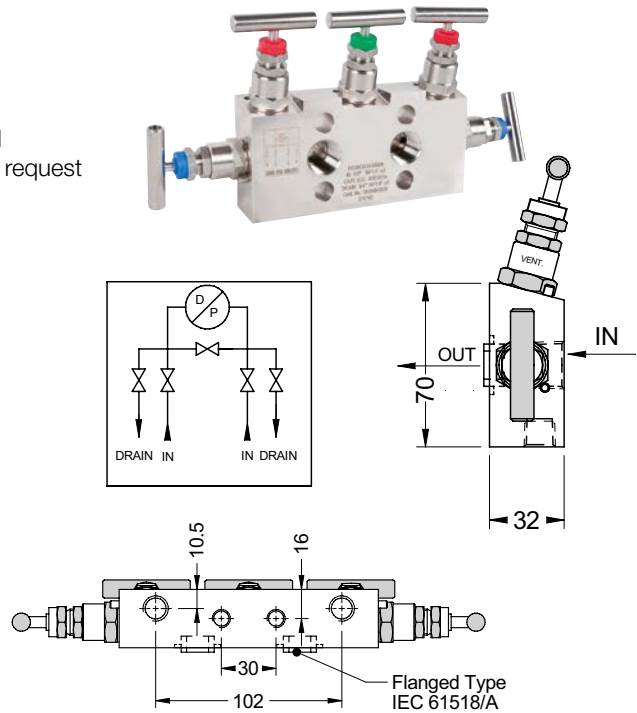
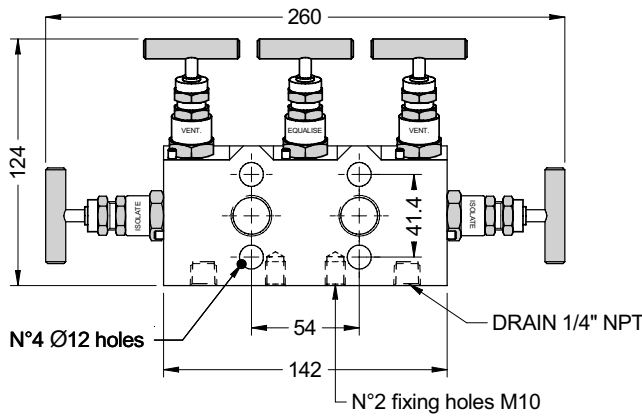

Included accessories:

- 4 carbon steel screws (stainless steel on request)
- 2 plugs
- 2 PTFE gaskets

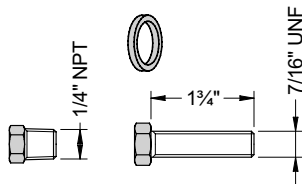

Order Code: V-5050CDAHIBAA (PTFE packing)

Possible ways of mounting 5-way manifold valve with PAD

Description	Process connection	Illustration
Valve mounted upside down on front side of PAD	1/2" NPT female	
Valve mounted on front side of PAD after rotating the head of PAD by 90° clockwise	1/2" NPT female	

Manifold valves (Direct mount, forged)

Technical Details

Material: stainless steel 316L

Pressure rating: 6000 psi

Temperature range: -73°C ... +210°C (PTFE packing), standard

-54°C ... +510°C (GRAPHOIL packing), on request

Weight: 2.25 kg

3-way Manifold valve

(inlet: flanged oval/outlet: flanged according to IEC 61518 Type B)

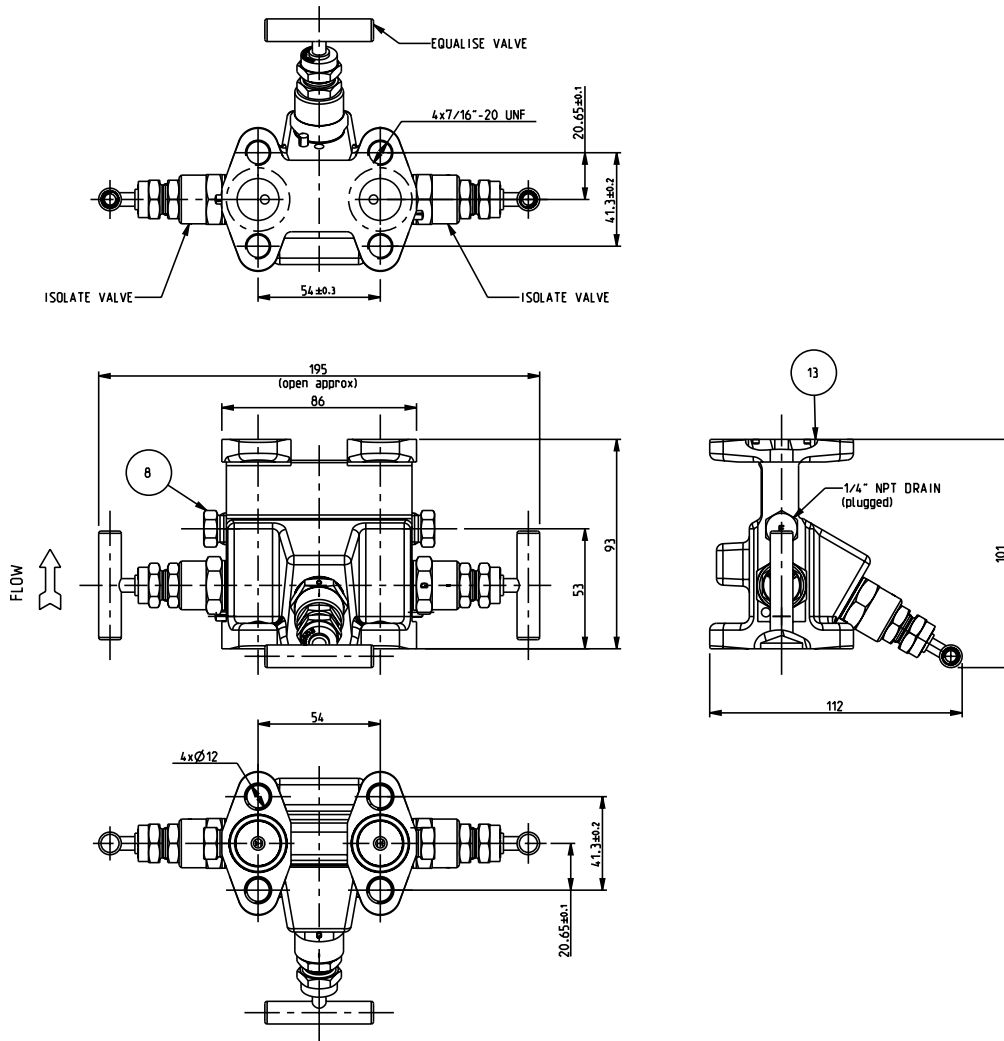

Included accessories:

4 carbon steel screws (stainless steel on request)

2 PTFE gaskets



Order Code: V-3454CHHHHBAA (PTFE packing)

Example of PAD direct assembled with (extended) diaphragm seal (not available as ATEX-Version)
 (for dimensional details, see DRM data sheet)

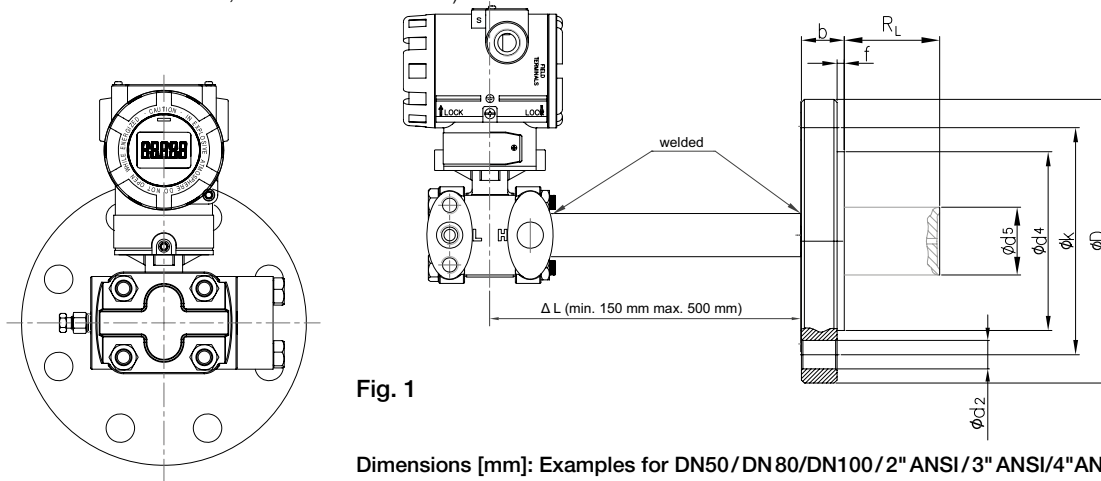

Fig. 1

Dimensions [mm]: Examples for DN50/DN80/DN100/2" ANSI/3" ANSI/4" ANSI

Flange type	D	k	d ²	b	f	d ⁴	X	d ⁵	R _L
DN50 PN16	165	125	18	18	2	102	4	48	50 mm (2")/ 100 mm (4")/ 150 mm (6")/ 200 mm (8")/ (customer specified)
DN50 PN40	165	125	18	20	2		4	48	
2" ANSI Cl. 150	152.4	120.6	19	19.1	2	92	4	48	
2" ANSI Cl. 300	165.1	127	19	22.3	2		8	48	
DN80 PN16	200	160	18	20	2	138	8	76	
DN80 PN40	200	160	18	24	2		8	76	
3" ANSI Cl. 150	190.5	152.4	19	23.9	1.6	127	4	76	
3" ANSI Cl. 300	209.5	168.3	22	28.4	1.6		8	76	
DN100 PN16	220	180	18	20	2	149	8	89	
DN100 PN40	235	190	22	24	2	149	8	89	
4" ANSI Cl. 150	228.6	190.5	19	24	1.6	157.2	8	89	
4" ANSI Cl. 300	254	200	22	32	1.6	157.2	8	89	

Example of PAD assembled with remote diaphragm seals and capillaries
 (for dimensional details, see DRM data sheet)

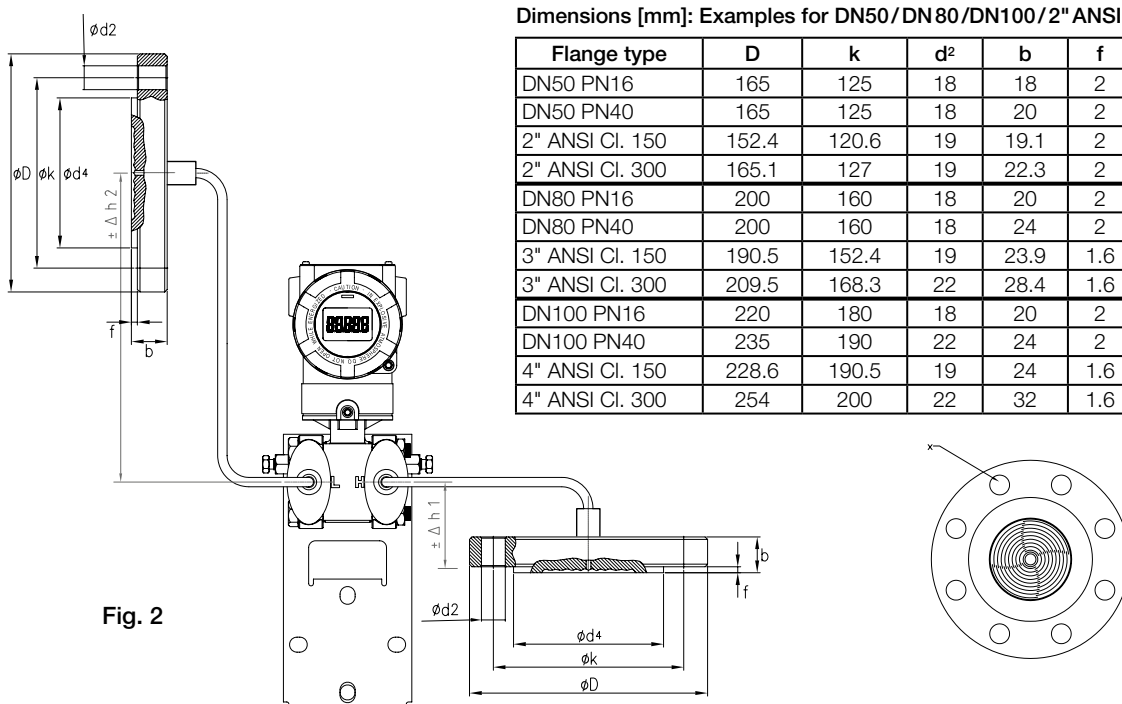

Fig. 2

Dimensions [mm]: Examples for DN50/DN80/DN100/2" ANSI/3" ANSI/4" ANSI

Flange type	D	k	d ²	b	f	d ⁴	X
DN50 PN16	165	125	18	18	2	102	4
DN50 PN40	165	125	18	20	2		4
2" ANSI Cl. 150	152.4	120.6	19	19.1	2	92	4
2" ANSI Cl. 300	165.1	127	19	22.3	2		8
DN80 PN16	200	160	18	20	2	138	8
DN80 PN40	200	160	18	24	2		8
3" ANSI Cl. 150	190.5	152.4	19	23.9	1.6	127	4
3" ANSI Cl. 300	209.5	168.3	22	28.4	1.6		8
DN100 PN16	220	180	18	20	2	149	8
DN100 PN40	235	190	22	24	2	149	8
4" ANSI Cl. 150	228.6	190.5	19	24	1.6	157.2	8
4" ANSI Cl. 300	254	200	22	32	1.6	157.2	8

Example of PAD-G remote assembled with (extended) diaphragm seal and capillary
 (for dimensional details, see DRM data sheet)

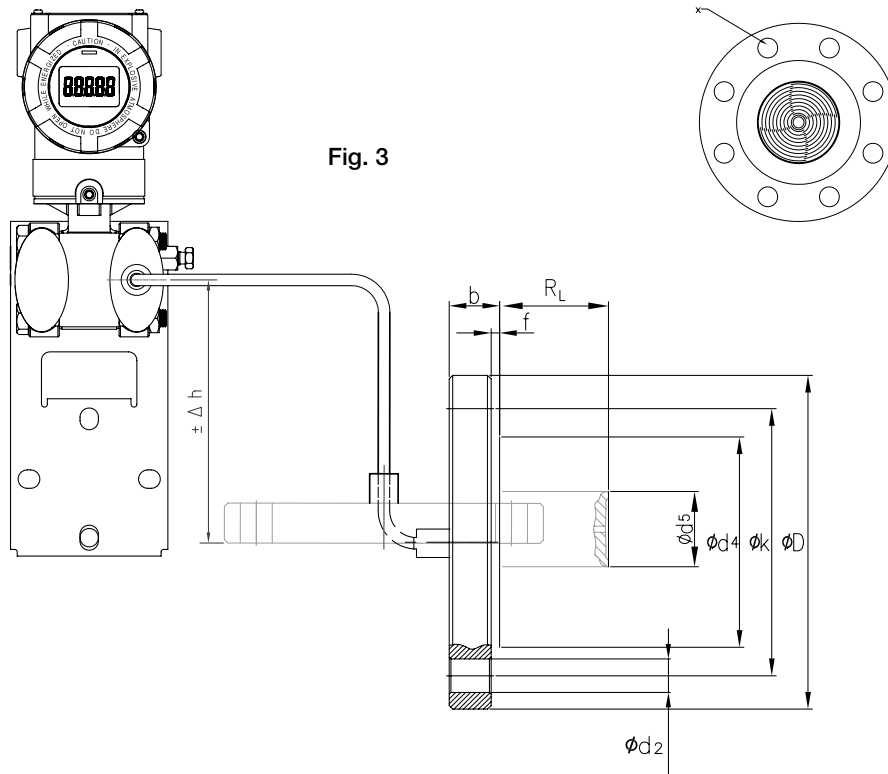

Fig. 3

Dimensions [mm]: Examples for DN50/DN80/DN100/2" ANSI/3" ANSI/4" ANSI

Flange type	D	k	d ²	b	f	d ⁴	X	d ⁵	R _L
DN50 PN16	165	125	18	18	2	102	4	48	50 mm (2")/ 100 mm (4")/ 150 mm (6")/ 200 mm (8")/ (customer specified)
DN50 PN40	165	125	18	20	2		4	48	
2" ANSI Cl. 150	152.4	120.6	19	19.1	2	92	4	48	
2" ANSI Cl. 300	165.1	127	19	22.3	2		8	48	
DN80 PN16	200	160	18	20	2	138	8	76	
DN80 PN40	200	160	18	24	2		8	76	
3" ANSI Cl. 150	190.5	152.4	19	23.9	1.6	127	4	76	
3" ANSI Cl. 300	209.5	168.3	22	28.4	1.6		8	76	
DN100 PN16	220	180	18	20	2	149	8	89	
DN100 PN40	235	190	22	24	2	149	8	89	
4" ANSI Cl. 150	228.6	190.5	19	24	1.6	157.2	8	89	
4" ANSI Cl. 300	254	200	22	32	1.6	157.2	8	89	



Diaphragm Seal Models (Remote assembly)*

(Standard device without additional options (e.g. coatings, special materials etc.).)

For dimensions/technical data, see DRM data sheet. Accuracy: 0.075% of calibrated span + influence of seal).

Over and under ranges of the min./max. span might be possible, but must be verified by Kobold for each application.

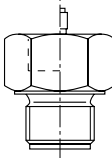
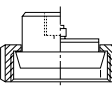
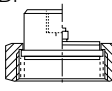
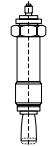
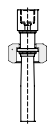
The indicated min./max. spans do not consider any coating of diaphragm seals. For additional information contact Kobold.

Model DRM	Size Code	Size	Note	Ø Diaphragm	Max. Medium Temperature	Min. Span [bar]	Max. Span [bar]
	R15	G ½	fixed male thread with capillary	Ø 18	+200 °C	0...6	1000
	R20	G ¾		Ø 23.8		0...2.5	1000
	R25	G 1		Ø 29.5		0...1.6	600
	R32	G 1 ¼		Ø 38		0...1	600
	R40	G 1 ½		Ø 40		0...1	600
	N15	½" NPT		Ø 18		0...6	1000
	N20	¾" NPT		Ø 18		0...6	1000
	N25	1" NPT		Ø 23.8		0...2.5	600
	N32	1 ¼" NPT		Ø 34.5		0...1.6	600
	M20	M20 x 1.5		Ø 18		0...6	600
	M48	M 48 x 3		Ø 40		0...1	600
	R20	DN 20	dairy connection, capillary	Ø 18	+200 °C	0...6	40
	R25	DN 25		Ø 23.8		0...2.5	40
	R32	DN 32		Ø 29.5		0...1.6	40
	R40	DN 40		Ø 38		0...1	40
	R50	DN 50		Ø 45.5		0...0.6	25
	R65	DN 65		Ø 64		0...0.4	25
	R80	DN 80		Ø 64		0...0.4	25
	R1H	DN 100		Ø 64		0...0.4	25
	R25	1"	IDF socket with union nut, capillary	Ø 29.5	+200 °C	0...1.6	40
	R40	1 ½"		Ø 42		0...1	40
	R50	2"		Ø 56		0...0.6	40
	R20	G¾	Capsule seal with rotatable male, capillary	short capsule	+350 °C	0...10	600
	R28	M28 x 1,5				0...10	600
	R20	G¾	Capsule seal with union nut, capillary	long capsule	+350 °C	0...1,6	600
	R25	G 1	Capsule seal with union nut, capillary	long capsule		0...1.6	600
	R40	1 ½"	SMS socket with union nut, capillary	Ø 34.5	+200 °C	0...1.6	40
	R50	2"		Ø 45.5		0...0.6	40

* Note: Threaded diaphragm seal only available with PAD-G/A. For PAD-D only flange and clamp connections are possible

Diaphragm Seal Models (Remote assembly) ...suite*

(Standard device without additional options (e.g. coatings, special materials etc.).

For dimensions/technical data, see DRM data sheet. Accuracy: 0.075% of calibrated span + influence of diaphragm seal).

Model DRM	Size Code	Size	Note	Ø Diaphragm	Max. Medium Temperature	Min. Span [bar]	Max. Span [bar]
DRM-613 Clamp 	R25	1"	Tri-Clamp, capillary	Ø 18	+200 °C	0...6	16
	F40	1 ½"		Ø 35.5		0...1.6	16
	F50	2"		Ø 45.5		0...0.6	16
	R65	2 ½"		Ø 52		0...0.6	16
	R80	3"		Ø 64		0...0.4	10
DRM-615 APV-RJT 	R20	1"	Union-nut, capillary	Ø 29.5	+200 °C	0...2.5	100
	R40	1 ½"		Ø 42.5		0...1	100
	R50	2"		Ø 56		0...0.6	100
DRM-617 	R45	M45 x 2	Union-nut, capillary	Ø 23.8	+120 °C	0...2.5	1600
DRM-620 	R20	G¾	Union-nut, capillary	Ø 23.8	+350 °C	0...2.5	600
DRM-620/1 	R20	G¾	Union-nut, capillary	Ø 23.8	+350 °C	0...2.5	600
DRM-622/1 	F48	Ø 48 mm	Flange, capillary	Ø 48	+200 °C	0...0.6	40
	F48 1	Ø 48 mm		Ø 48		0...0.6	40
	F48 2	Ø 48 mm		Ø 48		0...0.6	40
DRM-624/1 	F1H	Ø 100 mm	Flange, capillary	Ø 63.5	+250 °C	0...0.4	40
DRM-625/1 	R15	G½	Fix male, capillary	Ø 63.5	+250 °C	0...0.4	40
	N15	½" NPT				0...0.4	40
	I15	G½ male				0...0.4	40

* Note: Threaded diaphragm seal only available with PAD-G/A. For PAD-D only flange and clamp connections are possible

Diaphragm Seal Models (Direct or Remote assembly) ...suite*

(Standard device without additional options (e.g. coatings, special materials etc.))

For dimensions/technical data, see DRM data sheet. Accuracy: 0.075% of calibrated span + influence of diaphragm seal).

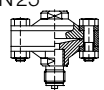
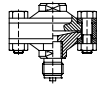
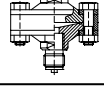
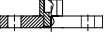
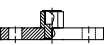
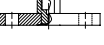
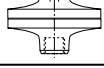
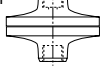
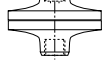
Model DRM	Size Code	Size	Note	Ø Diaphragm	Max. Medium Temperature	Min. Span [bar]	Max. Span [bar]
DRM-627 PN25 	R08A025	G ¼ male	Fix male, capillary	Ø 56	+250 °C	0...0.6	25
	R08I025	G ¼ female	Fix female, capillary	Ø 56		0...0.6	25
	R15A025	G ½ male	Fix male, capillary	Ø 56		0...0.6	25
	R15I025	G ½ female	Fix female, capillary	Ø 56		0...0.6	25
	N15A025	½" NPT male	Fix male, capillary	Ø 56		0...0.6	25
DRM-627 PN100 	R08A100	G ¼ male	Fix male, capillary	Ø 56	+250 °C	0...0.6	100
	R08I100	G ¼ female	Fix female, capillary	Ø 56		0...0.6	100
	R15A100	G ½ male	Fix male, capillary	Ø 56		0...0.6	100
	R15I100	G ½ female	Fix female, capillary	Ø 56		0...0.6	100
	N15A100	½" NPT male	Fix male, capillary	Ø 56		0...0.6	100
DRM-627 PN250 	R08A250	G ¼ male	Fix male, capillary	Ø 56	+250 °C	0...0.6	250
	R08I250	G ¼ female	Fix female, capillary	Ø 56		0...0.6	250
	R15A250	G ½ male	Fix male, capillary	Ø 56		0...0.6	250
	R15I250	G ½ female	Fix female, capillary	Ø 56		0...0.6	250
	N15A250	½" NPT male	Fix male, capillary	Ø 56		0...0.6	250
DRM-629 PN06 	F25P06	DN25	Flange to EN1092-1, capillary	Ø 24	+250 °C	0...2,5	6
	F32P06	DN32		Ø 30		0...2,5	6
	F40P06	DN40		Ø 38		0...1	6
	F50P06	DN50		Ø 48		0...0,6	6
	F65P06	DN65		Ø 64		0...0,4	6
	F80P06	DN80		Ø 64		0...0,4	6
	F1HP06	DN100		Ø 64		0...0,4	6
DRM-629 PN16 	F25P16	DN25	Flange to EN1092-1, capillary	Ø 24	+250 °C	0...2,5	16
	F32P16	DN32		Ø 30		0...2,5	16
	F40P16	DN40		Ø 38		0...1	16
	F50P16	DN50		Ø 48		0...0,6	16
	F65P16	DN65		Ø 64		0...0,4	16
	F80P16	DN80		Ø 64		0...0,4	16
	F1HP16	DN100		Ø 64		0...0,4	16
DRM-629 PN40 	F25P40	DN25	Flange to EN1092-1, capillary	Ø 24	+250 °C	0...2,5	40
	F32P40	DN32		Ø 30		0...2,5	40
	F40P40	DN40		Ø 38		0...1	40
	F50P40	DN50		Ø 48		0...0,6	40
	F65P40	DN65		Ø 64		0...0,4	40
	F80P40	DN80		Ø 64		0...0,4	40
	F1HP40	DN100		Ø 64		0...0,4	40
DRM-630/1 PVC 	R08	G ¼ female	Fix female, capillary	Ø 64	+40 °C	0...0,4	10
	R15	G ½ female		Ø 64		0...0,4	10
	N15	½" NPT female		Ø 64		0...0,4	10
DRM-631/1 PP 	R08	G ¼ female	Fix female, capillary	Ø 64	+40 °C	0...0,4	10
	R15	G ½ female		Ø 64		0...0,4	10
	N15	½" NPT female		Ø 64		0...0,4	10
DRM-632/1 PVDF 	R08	G ¼ female	Fix female, capillary	Ø 64	+50 °C	0...0,4	16
	R15	G ½ female		Ø 64		0...0,4	16
	N15	½" NPT female		Ø 64		0...0,4	16

* Note: Threaded diaphragm seal only available with PAD-G/A. For PAD-D only flange and clamp connections are possible



Diaphragm Seal Models (Direct or Remote assembly) ...suite*

(Standard device without additional options (e.g. coatings, special materials etc.).

For dimensions/technical data, see DRM data sheet. Accuracy: 0.075% of calibrated span + influence of diaphragm seal).

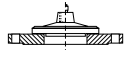
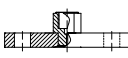
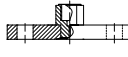
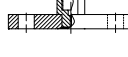
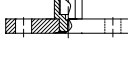
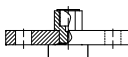
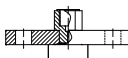
Model DRM	Size Code	Size	Note	Ø Diaphragm	Max. Medium Temperature	Min. Span [bar]	Max. Span [bar]
DRM-633/1 	F50	DN50	Flange to DIN2527 Form C, capillary	Ø 64	+250 °C	0...0.4	40
	F1H	DN100		Ø 64		0...0.4	40
DRM-635 150 lbs 	A25P150	1"	Flange to ASME B16.5, capillary	Ø 30	+250 °C	0...2,5	10
	A32P150	1 ¼"		Ø 38		0...1	10
	A40P150	1 ½"		Ø 38		0...1	10
	A50P150	2"		Ø 48		0...0,6	10
	A65P150	2 ½"		Ø 48		0...0,6	10
	A80P150	3"		Ø 64		0...0,4	10
	A90P150	3 ½"		Ø 64		0...0,4	10
	A1HP150	4"		Ø 64		0...0,4	10
DRM-635 300 lbs 	A25P300	1"	Flange to ASME B16.5, capillary	Ø 30	+250 °C	0...2.5	20
	A32P300	1 ¼"		Ø 38		0...1	20
	A40P300	1 ½"		Ø 38		0...1	20
	A50P300	2"		Ø 48		0...0.6	20
	A65P300	2 ½"		Ø 48		0...0.6	20
	A80P300	3"		Ø 64		0...0.4	20
	A90P300	3 ½"		Ø 64		0...0.4	20
	A1HP300	4"		Ø 64		0...0.4	20
DRM-635 600 lbs 	A25P600	1"	Flange to ASME B16.5, capillary	Ø 30	+250 °C	0...2.5	40
	A32P600	1 ¼"		Ø 38		0...1	40
	A40P600	1 ½"		Ø 38		0...1	40
	A50P600	2"		Ø 48		0...0.6	40
	A65P600	2 ½"		Ø 48		0...0.6	40
	A80P600	3"		Ø 64		0...0.4	40
	A90P600	3 ½"		Ø 64		0...0.4	40
	A1HP600	4"		Ø 64		0...0.4	40
DRM-635 1500 lbs 	A25P1K5	1"	Flange to ASME B16.5, capillary	Ø 30	+250 °C	0...2.5	100
	A32P1K5	1 ¼"		Ø 38		0...1	100
	A40P1K5	1 ½"		Ø 38		0...1	100
	A50P1K5	2"		Ø 48		0...0.6	100
	A65P1K5	2 ½"		Ø 48		0...0.6	100
	A80P1K5	3"		Ø 64		0...0.4	100
	A90P1K5	3 ½"		Ø 64		0...0.4	100
	A1HP1K5	4"		Ø 64		0...0.4	100
DRM-638 PN06 	F25P06	DN25	Flange to EN1092-1, capillary	Ø 24	+250 °C	0...2.5	6
	F32P06	DN32		Ø 30		0...2.5	6
	F40P06	DN40		Ø 38		0...1	6
	F50P06	DN50		Ø 48		0...0.6	6
	F65P06	DN65		Ø 64		0...0.4	6
	F80P06	DN80		Ø 64		0...0.4	6
	F1HP06	DN100		Ø 64		0...0.4	6
DRM-638 PN16 	F25P16	DN25	Flange to EN1092-1, capillary	Ø 24	+250 °C	0...2.5	16
	F32P16	DN32		Ø 38		0...2.5	16
	F40P16	DN40		Ø 38		0...1	16
	F50P16	DN50		Ø 48		0...0.6	16
	F65P16	DN65		Ø 48		0...0.4	16
	F80P16	DN80		Ø 64		0...0.4	16
	F1HP16	DN100		Ø 64		0...0.4	16

* Note: Threaded diaphragm seal only available with PAD-G/A. For PAD-D only flange and clamp connections are possible



Differential Pressure Transmitter Model PAD

Diaphragm Seal Models (Direct or Remote assembly) ...suite*

(Standard device without additional options (e.g. coatings, special materials etc.).)

For dimensions/technical data, see DRM data sheet. Accuracy: 0.075% of calibrated span + influence of diaphragm seal).

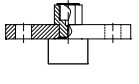
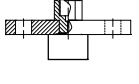
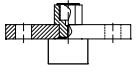
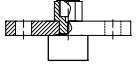
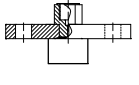
Model DRM	Size Code	Size	Note	Ø Diaphragm	Max. Medium Temperature	Min. Span [bar]	Max. Span [bar]
DRM-638 PN40 	F25P40	DN25	Flange to EN1092-1, capillary	Ø 30	+250 °C	0 ... 2.5	40
	F32P40	DN32		Ø 38		0 ... 2.5	40
	F40P40	DN40		Ø 38		0 ... 1	40
	F50P40	DN50		Ø 48		0 ... 0.6	40
	F65P40	DN65		Ø 48		0 ... 0.4	40
	F80P40	DN80		Ø 64		0 ... 0.4	40
	F1HP40	DN100		Ø 64		0 ... 0.4	40
DRM-640 150 lbs 	A25P150	1"	Flange to ASME B16.5, capillary	Ø 30	+250 °C	0 ... 35 psi	150 psi
	A32P150	1 ¼"		Ø 38		0 ... 15 psi	150 psi
	A40P150	1 ½"		Ø 38		0 ... 15 psi	150 psi
	A50P150	2"		Ø 48		0 ... 10 psi	150 psi
	A63P150	2 ½"		Ø 48		0 ... 10 psi	150 psi
	A75P150	3"		Ø 64		0 ... 5 psi	150 psi
	A85P150	3 ½"		Ø 64		0 ... 5 psi	150 psi
DRM-640 300 lbs 	A25P300	1"	Flange to ASME B16.5, capillary	Ø 30	+250 °C	0 ... 35 psi	300 psi
	A32P300	1 ¼"		Ø 38		0 ... 15 psi	300 psi
	A40P300	1 ½"		Ø 38		0 ... 15 psi	300 psi
	A50P300	2"		Ø 48		0 ... 10 psi	300 psi
	A63P300	2 ½"		Ø 48		0 ... 10 psi	300 psi
	A75P300	3"		Ø 64		0 ... 5 psi	300 psi
	A85P300	3 ½"		Ø 64		0 ... 5 psi	300 psi
DRM-640 600 lbs 	A25P600	1"	Flange to ASME B16.5, capillary	Ø 30	+250 °C	0 ... 35 psi	600 psi
	A32P600	1 ¼"		Ø 38		0 ... 15 psi	600 psi
	A40P600	1 ½"		Ø 38		0 ... 15 psi	600 psi
	A50P600	2"		Ø 48		0 ... 10 psi	600 psi
	A63P600	2 ½"		Ø 48		0 ... 10 psi	600 psi
	A75P600	3"		Ø 64		0 ... 5 psi	600 psi
	A85P600	3 ½"		Ø 64		0 ... 5 psi	600 psi
DRM-640 1500 lbs 	A25P1K5	1"	Flange to ASME B16.5, capillary	Ø 30	+250 °C	0 ... 35 psi	1500 psi
	A32P1K5	1 ¼"		Ø 38		0 ... 15 psi	1500 psi
	A40P1K5	1 ½"		Ø 38		0 ... 15 psi	1500 psi
	A50P1K5	2"		Ø 48		0 ... 10 psi	1500 psi
	A63P1K5	2 ½"		Ø 48		0 ... 10 psi	1500 psi
	A75P1K5	3"		Ø 64		0 ... 5 psi	1500 psi
	A1HP1K5	4"		Ø 64		0 ... 5 psi	1500 psi

* Note: Threaded diaphragm seal only available with PAD-G/A. For PAD-D only flange and clamp connections are possible



Diaphragm Seal Models (Direct or Remote assembly) ...suite*

(Standard device without additional options (e.g. coatings, special materials etc.).

For dimensions/technical data, see DRM data sheet. Accuracy: 0.075% of calibrated span + influence of diaphragm seal).

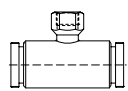
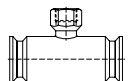
Model DRM	Size Code	Size	Note	Ø Diaphragm	Max. Medium Temperature	Min. Span [bar]	Max. Span [bar]
DRM 501 ISO Sterile 	D15	DN15	Inline, capillary	Inline	+80 °C	0...2.5	40
	D20	DN20		Inline		0...2.5	40
	D25	DN25		Inline		0...1	40
	D32	DN32		Inline		0...1	40
	D40	DN40		Inline		0...0.6	40
	D50	DN50		Inline		0...0.6	40
DRM 503 Clamp ISO 2852 	D15	DN15	Inline, capillary	Inline	+80 °C	0...1.6	40
	D20	DN20		Inline		0...1.6	40
	D25	DN25		Inline		0...0.6	40
	D32	DN32		Inline		0...0.6	40
	D40	DN40		Inline		0...0.4	40
	D50	DN50		Inline		0...0.4	40

* Note: Threaded diaphragm seal only available with PAD-G/A. For PAD-D only flange and clamp connections are possible



Application Index

Please fill out the following Application Data Sheet while inquiring/ordering model PAD assembled with diaphragm seal model DRM

Order/ Inquiry Ref./ Item No.

Pressure Transmitter (Model, Calibration range)	
Diaphragm Seal (Model, Size Code)	
Diaphragm material of DRM (wetted part)	
Process connection material of DRM (wetted part)	

Medium:	
Operating density	g/cm ²
Operating viscosity	cSt

Temperature:	nominal	minimal	maximal	
Medium temperature:				°C/°F
Ambient temperature:				°C/°F
Rinsing temperature diaphragm seal				°C/°F
Rinsing temperature capillary				°C/°F

Pressure specification:	Value	
1.1) Operating pressure static	or 1.2	bar/psi
1.2) Operating pressure dynamic min + max	or 1.3	bar/psi
1.3) Operating pressure as frequency in Hz		Hz
2.) max. negative pressure		
3.) max. over pressure		
4.1) Display damping: without / light / middle / strong	or 4.2	
4.2) Pressure decrease with time + range		

Arrangement with rectangular Connection Rod (Fig. 1):	
1.) Connecting Rod Length ($\Delta L = \text{min. } 150 \text{ mm}/\text{max. } 500 \text{ mm}$) at HP port 'H'	mm

Arrangement with capillary:		
1.) Diaphragm seal needed on both ports	Yes	
	No (diaphragm seal connected to high pressure port 'H')	
2.) If answer to 1) is YES, same model diaphragm seal on both ports	Yes	
	No	
3.) If answer to 2) is NO, specify DRM models at each port	DRM model at high pressure port 'H'	
	DRM model at low pressure port 'L'	

...continued...



Application Index (suite)
Order/ Inquiry Ref./ Item No.

Arrangement with capillary (suite): 4.) Orientation of diaphragm seals (Tick mark the appropriate box, see Fig. 2)	Diaphragm seal at port 'H', sealing surface facing DOWN	
	Diaphragm seal at port 'H', sealing surface facing RIGHT	
	Diaphragm seal at port 'H', sealing surface facing LEFT	
	Diaphragm seal at port 'H', sealing surface facing UP	
	Diaphragm seal at port 'H', special orientation, provide sketch	
	Diaphragm seal at port 'L', sealing surface facing DOWN	
	Diaphragm seal at port 'L', sealing surface facing RIGHT	
	Diaphragm seal at port 'L', sealing surface facing LEFT	
	Diaphragm seal at port 'L', sealing surface facing UP	
	Diaphragm seal at port 'L', special orientation, provide sketch	

Capillary:	
length in 'mm' at port 'H' (if other units, please specify)	mm
length in 'mm' at port 'L' (if other units, please specify)	mm
protection hose required (yes/no)	

Height Adjustment:		
1.) Factory calibration for height adjustment required	No	
	Yes, choose from the following option(s) 2...5	
2.) PAD higher than DRM at port 'H' (Fig. 2 or 3), specify $+\Delta h(1)$		mm
3.) PAD lower than DRM at port 'H' (Fig. 2 or 3), specify $-\Delta h(1)$		mm
Following options "4" and "5" not valid while ordering PAD-G...		
4.) PAD higher than DRM at port 'L' (Fig. 2), specify $+\Delta h(2)$		mm
5.) PAD lower than DRM at port 'L' (Fig. 2), specify $-\Delta h(2)$		mm

Options: Extended diaphragm seal at both ports (see Fig. '1' or Fig. '3' for dimension R_L , tick only if option needed)	
No (extended diaphragm seal only at port 'H')	
If No, length ' R_L ' of extended diaphragm seal at port 'H'	
Yes	
If Yes, length ' R_L ' of extended diaphragm seal at port 'H'	mm
If Yes, length ' R_L ' of extended diaphragm seal at port 'L'	mm

Filling liquid (Tick mark the desired box)	
Glycerine oil (silicone free, food grade) for Operation temperature (-10...+80 °C)	
Paraffine oil (silicone free, food grade) for Operation temperature (-10...+120 °C)	
Silicone oil for Operation temperature (-40...+200 °C)	
Silicone oil for Operation temperature (-20...+350 °C)	
Silicone oil for Operation temperature (-20...+400 °C)	