

▼ ZE4204TE-QHR



- **Auto-Cycle feature provides continuous cycle operation of the torque wrench as long as the advance button is pressed (pump can be used with or without auto cycle feature)**
- **LCD readout provides pressure and torque display and a number of diagnostic and readout capabilities never before offered on a portable electric pump**
- **Totally enclosed, fan-cooled industrial electric motors supply extended life and stand up to harsh industrial environments**
- **High-strength, molded electrical enclosure protects electronics, power supplies and LCD readout from harsh environments.**

Z

**Tough,
Dependable
Innovative
CLASS**



Pro-Series

Back-lit LCD and Pressure Transducer featuring Auto-Cycle Technology.

- Torque wrench model is selectable
- "Auto cycle" setting easily programmable.
- Digital read-out and "Autocycle" setting
- Pump usage information, hour and cycle counts
- Low-voltage warning and recording
- Self-test and diagnostic capabilities
- Information can be displayed in English, French, German, Italian, Spanish and Portuguese
- Pressure transducer is more accurate and durable than analog gauges
- Easy-viewing variable rate display
- Display pressure in bar, MPa or psi.



◀ *The ZE4T-Series torque wrench pumps are perfectly matched for this W2000X wrench.*



Bolting Integrity Software

Enerpac Bolting Integrity Software Solutions play a key role in

implementing and managing an Integrity Program for bolted connections.

The software offers Tool selection, Bolt Load calculations and Tool pressure settings, as well as, a combined Application Data Sheet and Joint Completion Report.

Custom Joint information can also be entered.

ZE4T AND ZE5T-SERIES OIL FLOW VERSUS PRESSURE

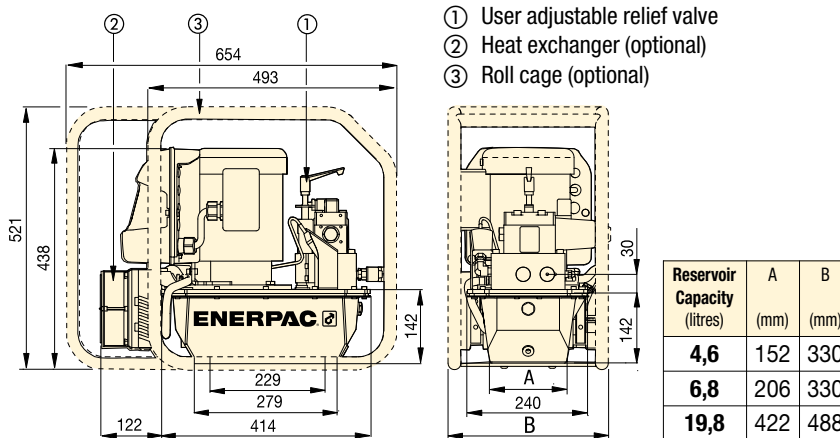
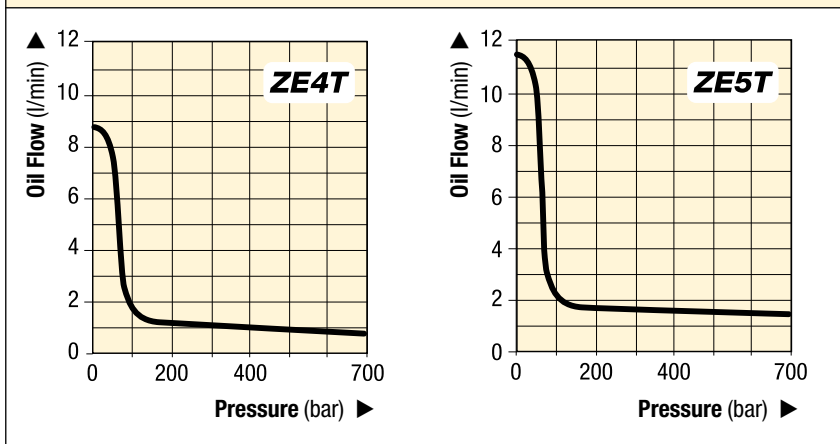

ZE4T and ZE5T-Series

▼ PERFORMANCE CHART

Pump Series	Output Flow Rate at 50 Hz (l/min)				Motor Size (kW)	Relief Valve Adjustment Range (bar)	Sound Level (dBA)
	7 bar	50 bar	350 bar	700 bar			
ZE4T	8,8	8,1	0,9	0,8	1,1	70 - 700	75
ZE5T	11,8	11,2	1,7	1,6	2,2	70 - 700	75

For Use With Wrenches	Model Number ¹⁾	Reservoir Capacity (litres)	Factory Installed Accessories			Weight (kg)
			Heat Exchanger	Roll Cage	4-Wrench Manifold	
All Series	ZE4204TE-QR (B)	4,6		●		54
	ZE4204TE-QHR (B)	4,6	●	●		59
	ZE4208TE-QHR (B)	6,8	●	●		61
	ZE4208TE-QHMR (B)	6,8	●	●	●	64
All Series	ZE5204TW-QHR (G, J)	4,6	●	●		64
	ZE5208TW-QHR (G, J)	6,8	●	●		67
	ZE5208TW-QHMR (G, J)	6,8	●	●	●	70
	ZE5220TW-QHR (G, J)	19,8	●	●		88

¹⁾ "B" suffix model numbers shown are 115 VAC, 1-phase, 50/60 Hz. Model number order example: **ZE4204TB-QR**.
 "E" indicates pump available in 208-240 VAC, 1 phase, 50/60 Hz with European plug and CE EMC compliant.
 "J" indicates pump available in 460-480 VAC, 3-phase, 50/60 Hz. Model number order example: **ZE5208TJ-QHR**.
 "G" indicates pump available in 208-240 VAC, 3-phase, 50/60 Hz. Model number order example: **ZE5208TG-QHR**.
 "W" indicates pump available in 380-415 VAC, 3-phase, 50/60 Hz. Model number order example: **ZE5208TW-QHR**.

ZE4T ZE5T Series



Reservoir Capacity:
4,6 - 19,8 litres

Flow at Rated Pressure:
0,82 - 1,64 l/min

Motor Size:
1,1 - 2,2 kW

Maximum Operating Pressure:
700 bar



Torque Wrench Pump Selection Matrix

For optimum speed and performance see the torque wrench pump and hose selection matrix.

Page: 265



Accessories

Descriptions can be found in the ZU4T-Series pump section.

Page: 274



Torque Wrench Hoses

Use Enerpac 700 bar THQ-Series torque wrench hoses with torque wrenches and pumps.

2 m long, 2 hoses	THQ702T
6 m long, 2 hoses	THQ706T
12 m long, 2 hoses	THQ712T