



Bourdon Tube Pressure Gauges

acc. to EN 837 · for Industrial Applications



measuring
•
monitoring
•
analysing

MAN-R/MAN-Q

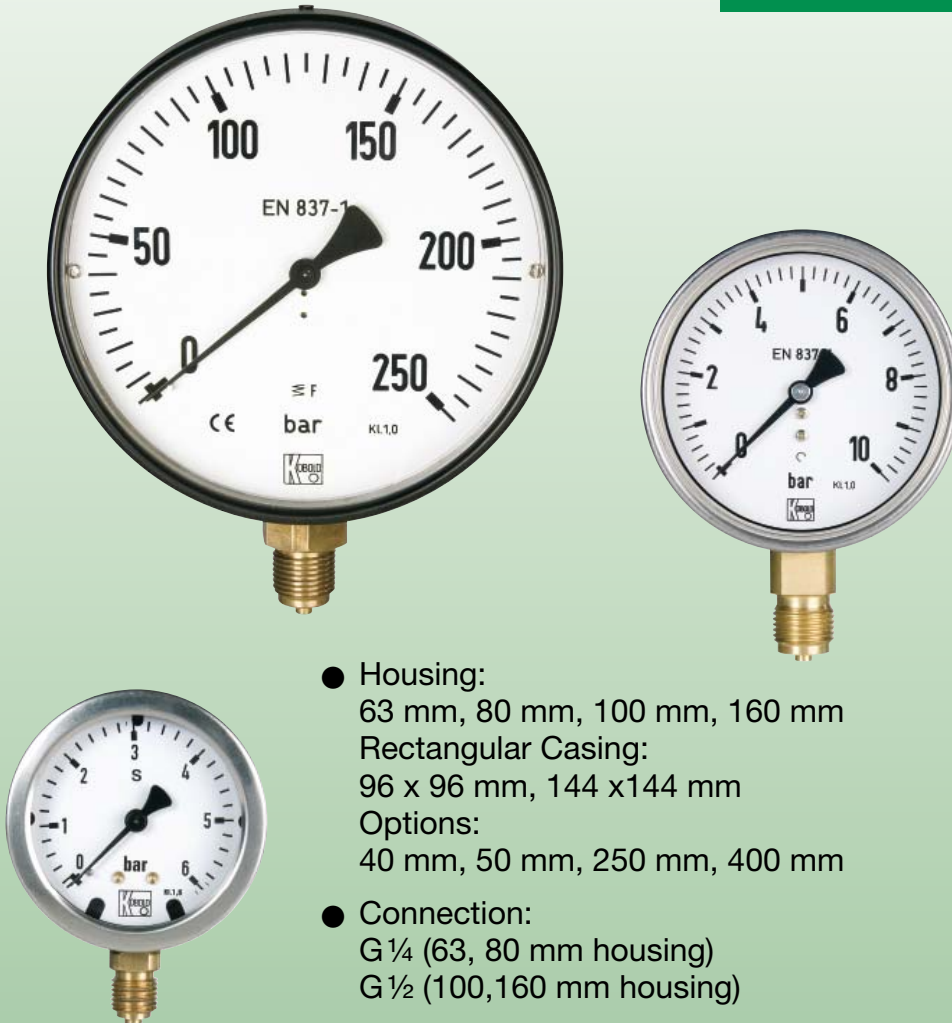

- Housing:
63 mm, 80 mm, 100 mm, 160 mm
Rectangular Casing:
96 x 96 mm, 144 x 144 mm
Options:
40 mm, 50 mm, 250 mm, 400 mm
- Connection:
G ¼ (63, 80 mm housing)
G ½ (100, 160 mm housing)
- Material
Housing: stainless steel, aluminium
Connection: brass
- Measuring ranges:
-1 ... 0 bar ... 0 ... +1000 bar
- Options: liquid filling;
contacts; transmitter



P1

KOBOLD companies worldwide:

ARGENTINA, AUSTRIA, BELGIUM, BULGARIA, CANADA, CHILE, CHINA, COLOMBIA, CZECHIA, DOMINICAN REPUBLIC, EGYPT, FRANCE, GERMANY, GREAT BRITAIN, HUNGARY, INDIA, INDONESIA, ITALY, MALAYSIA, MEXICO, NETHERLANDS, PERU, POLAND, ROMANIA, SINGAPORE, SOUTH KOREA, SPAIN, SWITZERLAND, TAIWAN, THAILAND, TUNISIA, TURKEY, USA, VIETNAM

KOBOLD Messring GmbH
Nordring 22-24
D-65719 Hofheim/Ts.
Head Office:
+49(0)6192 299-0
+49(0)6192 23398
info.de@kobold.com
www.kobold.com



Application

These KOBOLD pressure gauges can be used for all applications where accuracy, repeatability and long-term stability are of special importance. They can be used for liquid or gaseous substances which do not crystallize, are not highly viscous and do not corrode brass.

The extensive range of options allows the user to adapt the instruments to his own special requirements. All the pressure gauges comply with general international guidelines and take account of standard as well as application-specific requirements. KOBOLD Bourdon tube pressure gauges are the result of over 70 years experience in building pressure gauges.

Measuring principle

Mechanical pressure measurement uses the principle of an elastic measuring element, which generates a precisely defined, reproducible deflection when subjected to pressure. The motion works convert this into a rotary motion of the pointer. The pressure at the measuring element can be read on the scale of the dial.

Housing

The following housing diameters are available: 63 mm, 80 mm, 100 mm and 160 mm. The housing is made of stainless steel. As an alternative to the 100 mm or 160 mm diameter pressure gauge, the devices can also be supplied with a robust aluminium housing. This option is only available from KOBOLD and has proven ideal for very robust use in filled equipment, e.g. in ship's diesel engines. It is also available with a rectangular profile housing for integration into control panels. This is available as 96 x 96 mm and 144 x 144 mm versions. Housings are optionally available with 40 mm, 50 mm, 250 mm or 400 mm nominal diameters.

Unifilar drawing

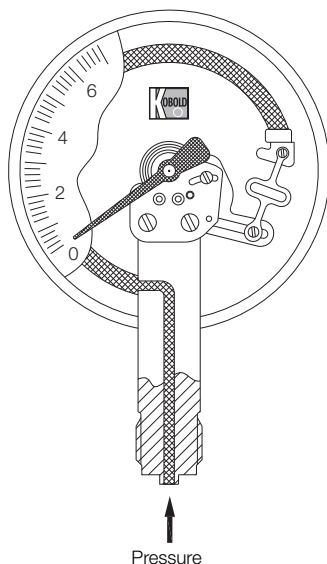

Installation

The gauges are most often installed straight into the customer's screw necks. Optional gauge models with an installation border on the front are also available for installation into or onto control panels.

Connection

The gauges with 63 and 80 mm housing diameter are supplied with a G $\frac{1}{4}$ connecting thread as standard, gauges with housing diameter of 100 mm and above with G $\frac{1}{2}$ connecting thread. The connection is made of brass. Diaphragm seals can be mounted for viscous, crystallising, aggressive materials or higher temperature materials to prevent the material being measured from penetrating into the measuring system. Other connection types are available on request.

Measuring ranges

The measuring ranges are graduated according to DIN recommendations and lie between -1...0 bar and 0...1000 bar. Other scales with measuring ranges in PSI, Pa or with your company logo are available on request.

Damping liquid

Pressure gauges with liquid filling are used in locations with high alternating dynamic loads, strong vibrations and pulses. The filling ensures easy readability through steady pointer movement even when subjected to extreme loading and heavy vibration. The lubricating effect of the glycerine also keeps wear to a minimum. Glycerine is always used as a matter of principle. In gauges with a contact or an electrical measuring transducer, liquid paraffin is used as a non-conductive alternative. Silicon fillings of various viscosities are also optionally available.

Contacts





For monitoring the system pressure, gauges with 100 mm or 160 mm diameter can be fitted with up to four limit contacts. Slow action, magnetic spring, inductive and pneumatic contacts are also available (see Chapter »Contact Fittings for Pressure Gauges«).

Fields of application

- Mechanical engineering
- Hydraulics
- Compressors
- Pumps
- Plant construction







Technical Details · NG 63/80, Rectangular Casing

Connection/Housing	Round housing			Profile housing		
	NG 63	NG 63	NG 80	96x96	144x144	
Model						
Bottom connection 	MAN-...	...RD21...	...RD71...	...RE22...	-	-
Back connection 	MAN-...	...RD23... central	...RD73... central	...RE24... eccentric	-	-
Triangular front ring with clamp, Back connection 	MAN-...	...RD23B... central	...RD73B... central	...RE24K... eccentric	...QF14B...	...QG14B...
Front flange Back connection 	MAN-...	...RD23V... central	...RD73V... central	...RE24V... eccentric	-	-
Accuracy class	1.0			1.6		
Housing version	stainless steel 1.4301			steel, nickel plated		
Filling	-	glycerine	-	-	-	
Ring/housing	stainless steel 1.4301			light metal / steel, nickel plated		
Pointer	aluminium, black anodized, partly plastic			aluminium, black anodized		
Movement	brass					
Throttle	from 60 bar D = 0.5 mm					
Window	Polycarbonate			instrument glass		
Measuring element	CuSn (from 100 bar stainless steel 1.4571)					
Protection	IP 65	IP 67	IP 65	IP 54 from ahead		
Overrange protection	1.2 times		short-term 1.3 times (from 1000 bar 1.1 times) of full scale			
Weight	siehe Tabelle		0.4 kg	0.7 kg	1.2 kg	
Ambient temperature	-20 ... +60 °C					
Connection	brass					
Thread connection	G ¼ male			G ½ male		
Max. medium temperature	80 °C					
Contacts	no			yes, max. 4 contacts		
Options	Trailing pointer, marking pointer, oil-free and decreased, special scale					
Indicating range	Code of indicating range					
-0.6 ... 0 bar	-	-	..AC	..AC	..AC	
-1 ... 0 bar	..AD	..AD	..AD	..AD	..AD	
-1 ... +0.6 bar	..A0	..A0	..A0	..A0	..A0	
-1 ... +1.5 bar	..A1	..A1	..A1	..A1	..A1	
-1 ... +3 bar	..A2	..A2	..A2	..A2	..A2	
-1 ... +5 bar	..A3	..A3	..A3	..A3	..A3	
-1 ... +9 bar	..A4	..A4	..A4	..A4	..A4	
-1 ... +15 bar	..A5	..A5	..A5	..A5	..A5	
0 ... 0.6 bar	-	-	-	..B1	..B1	
0 ... 1 bar	..B2	..B2	..B2	..B2	..B2	
0 ... 1.6 bar	..B3	..B3	..B3	..B3	..B3	
0 ... 2.5 bar	..B4	..B4	..B4	..B4	..B4	
0 ... 4 bar	..B5	..B5	..B5	..B5	..B5	
0 ... 6 bar	..B6	..B6	..B6	..B6	..B6	
0 ... 10 bar	..B7	..B7	..B7	..B7	..B7	
0 ... 16 bar	..B8	..B8	..B8	..B8	..B8	
0 ... 25 bar	..B9	..B9	..B9	..B9	..B9	
0 ... 40 bar	..B0	..B0	..B0	..B0	..B0	
0 ... 60 bar	..C1	..C1	..C1	..C1	..C1	
0 ... 100 bar	..C2	..C2	..C2	..C2	..C2	
0 ... 160 bar	..C3	..C3	..C3	..C3	..C3	
0 ... 250 bar	..C4	..C4	..C4	..C4	..C4	
0 ... 400 bar	..C5	..C5	..C5	..C5	..C5	
0 ... 600 bar	..C6	..C6	..C6	..C6	..C6	
0 ... 1000 bar	-	-	-	..D7	..D7	







Technical Details · NG 100

Connection/Housing		Model			
Bottom connection 	MAN-...	...RF22...	...RF32...	...RF72...	...RF62...
Back connection 	MAN-...	...RF24... eccentric	...RF34... eccentric	...RF74... eccentric	...RF64... eccentric
Triangular front ring with clamp, back connection 	MAN-...	...RF24K... eccentric	...RF34K... eccentric	-	...RF64K... eccentric
Front flange Back connection 	MAN-...	...RF24V... eccentric	...RF34V... eccentric	...RF74V... eccentric	...RF64V... eccentric
Accuracy class	1.0				
Housing version	stainless steel 1.4301	aluminium	stainless steel 1.4301	aluminium	
Filling	- glycerine (paraffin with contact)				
Ring	stainless steel 1.4301	steel black	stainless steel 1.4301	steel black	
Pointer	aluminium, black anodized				
Movement	brass				
Throttle	from 60 bar D = 0.5 mm				
Window	instrument glass				
Measuring element	CuSn (from 100 bar stainless steel 1.4571)				
Protection	IP 65		IP 67		
Overrange protection	short-term 1.3 times (from 1000 bar 1.1 times) of full scale				
Weight	see table				
Ambient temperature	-20 ... +60 °C				
Connection	brass				
Thread connection	G ½ male				
Max. medium temperature	80 °C				
Contacts	max. 3	max. 4	max. 3	max. 4	
Options	Trailing pointer, marking pointer, oil-free and decreased, special scale				
Indicating range	Code of indicating range				
-0.6 ... 0 bar	..AC	..AC	..AC	..AC	
-1 ... 0 bar	..AD	..AD	..AD	..AD	
-1 ... +0.6 bar	..A0	..A0	..A0	..A0	
-1 ... +1.5 bar	..A1	..A1	..A1	..A1	
-1 ... +3 bar	..A2	..A2	..A2	..A2	
-1 ... +5 bar	..A3	..A3	..A3	..A3	
-1 ... +9 bar	..A4	..A4	..A4	..A4	
-1 ... +15 bar	..A5	..A5	..A5	..A5	
0 ... 0.6 bar	..B1	..B1	..B1	..B1	
0 ... 1 bar	..B2	..B2	..B2	..B2	
0 ... 1.6 bar	..B3	..B3	..B3	..B3	
0 ... 2.5 bar	..B4	..B4	..B4	..B4	
0 ... 4 bar	..B5	..B5	..B5	..B5	
0 ... 6 bar	..B6	..B6	..B6	..B6	
0 ... 10 bar	..B7	..B7	..B7	..B7	
0 ... 16 bar	..B8	..B8	..B8	..B8	
0 ... 25 bar	..B9	..B9	..B9	..B9	
0 ... 40 bar	..B0	..B0	..B0	..B0	
0 ... 60 bar	..C1	..C1	..C1	..C1	
0 ... 100 bar	..C2	..C2	..C2	..C2	
0 ... 160 bar	..C3	..C3	..C3	..C3	
0 ... 250 bar	..C4	..C4	..C4	..C4	
0 ... 400 bar	..C5	..C5	..C5	..C5	
0 ... 600 bar	..C6	..C6	..C6	..C6	
0 ... 1000 bar	..D7	..D7	..D7	..D7	



Technical Details · NG 160

Connection/Housing		Model			
Bottom connection 	MAN-...	...RG22...	...RG32...	...RG72...	...RG62...
Back connection 	MAN-...	...RG24... eccentric	...RG34... eccentric	...RG74... eccentric	...RG64... eccentric
Triangular front ring and clamp, back connection 	MAN-...	-	...RG34K... eccentric	-	...RG64K... eccentric
Front flange Back connection 	MAN-...	...RG24V... eccentric	...RG34V... eccentric	...RG74V... eccentric	...RG64V... eccentric
Accuracy class	1.0				
Housing version	stainless steel 1.4301		aluminium	stainless steel 1.4301	aluminium
Filling	- glycerine (paraffine with contact)				
Ring	stainless steel 1.4301		steel black	stainless steel 1.4301	steel black
Pointer	aluminium, black anodized				
Movement	brass				
Throttle	from 60 bar D = 0.5 mm				
Window	instrument glass				
Measuring element	CuSn (from 100 bar stainless steel 1.4571)				
Protection	IP 65			IP 67	
Overrange protection	short-term 1.3 times (from 1000 bar 1.1 times) of full scale				
Weight	see table				
Ambient temperature	-20 ... +60 °C				
Connection	brass				
Thread connection	G ½ male				
Max. medium temperature	80 °C				
Contacts	max. 3	max. 4	max. 3	max. 4	
Options	Trailing pointer, marking pointer, oil-free and decreased, special scale				
Indicating range	Code of indicating range				
-0.6 ... 0 bar	..AC	..AC	..AC	..AC	
-1 ... 0 bar	..AD	..AD	..AD	..AD	
-1 ... +0.6 bar	..A0	..A0	..A0	..A0	
-1 ... +1.5 bar	..A1	..A1	..A1	..A1	
-1 ... +3 bar	..A2	..A2	..A2	..A2	
-1 ... +5 bar	..A3	..A3	..A3	..A3	
-1 ... +9 bar	..A4	..A4	..A4	..A4	
-1 ... +15 bar	..A5	..A5	..A5	..A5	
0 ... 0.6 bar	..B1	..B1	..B1	..B1	
0 ... 1 bar	..B2	..B2	..B2	..B2	
0 ... 1.6 bar	..B3	..B3	..B3	..B3	
0 ... 2.5 bar	..B4	..B4	..B4	..B4	
0 ... 4 bar	..B5	..B5	..B5	..B5	
0 ... 6 bar	..B6	..B6	..B6	..B6	
0 ... 10 bar	..B7	..B7	..B7	..B7	
0 ... 16 bar	..B8	..B8	..B8	..B8	
0 ... 25 bar	..B9	..B9	..B9	..B9	
0 ... 40 bar	..B0	..B0	..B0	..B0	
0 ... 60 bar	..C1	..C1	..C1	..C1	
0 ... 100 bar	..C2	..C2	..C2	..C2	
0 ... 160 bar	..C3	..C3	..C3	..C3	
0 ... 250 bar	..C4	..C4	..C4	..C4	
0 ... 400 bar	..C5	..C5	..C5	..C5	
0 ... 600 bar	..C6	..C6	..C6	..C6	
0 ... 1000 bar	..D7	..D7	..D7	..D7	



Dimensions

Bottom connection

Code	NG	A	B without contact	B 1 or 2 contacts	B 3 contacts	B 4 contacts	C	d	D	E	AF	W	X
MAN-RD 21/71	63 mm	6	31	-	-	-	13	52	68	55	14	-	-
MAN-RE 22	80 mm	5	43.5	-	-	-	16	80	84	76	22	-	-
MAN-RF 22/72	100 mm VA	17	48	82	97	110	15	100	101	86.5	22	0	88
MAN-RF 32/72	100 mm Alu	-	43	91	107	107	15	100	-	86.5	27	0	88
MAN-RG 22/72	160 mm VA	21	50	101	120	120	15	159	162	117	22	0	118
MAN-RG 32/62	160 mm Alu	-	48	101	127	127	18.5	160	-	115	27	25°	118

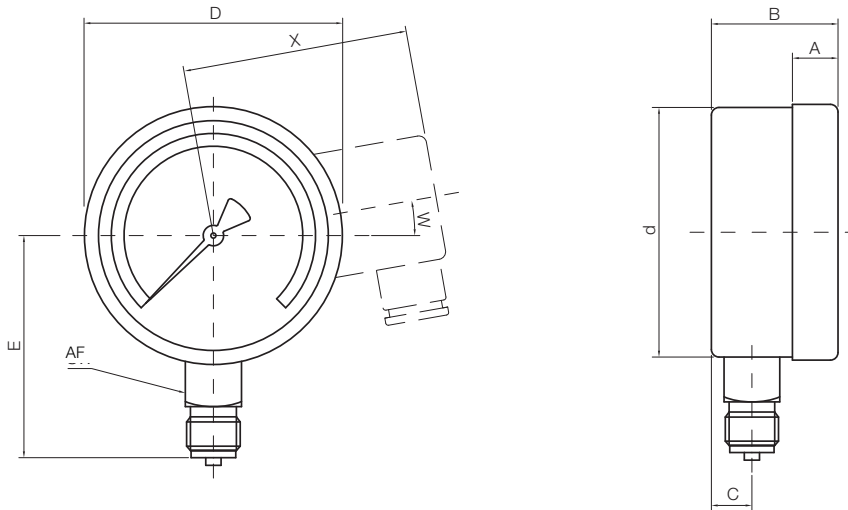

Back connection

Code	NG	A	B without contact	B 1 or 2 contacts	B 3 contacts	B 4 contacts	C	d	D	E	AF	W	X
MAN-RD 23/73	63 mm	6	28	-	-	-	26	63	68	0	14	-	-
MAN-RE 24	80 mm	5	43.5	-	-	-	35	80	84	0	22	-	-
MAN-RF 24/74	100 mm VA	17	49	82	97	110	36	100	101	32.5	17	0	88
MAN-RF 34/64	100 mm Alu	-	43	91	107	107	34	100	-	32.5	27	0	88
MAN-RG 24/74	160 mm VA	21	50	101	120	120	34	159	162	32.5	17	0	118
MAN-RG 34/64	160 mm Alu	-	48	101	127	127	30	160	-	50	27	25°	118

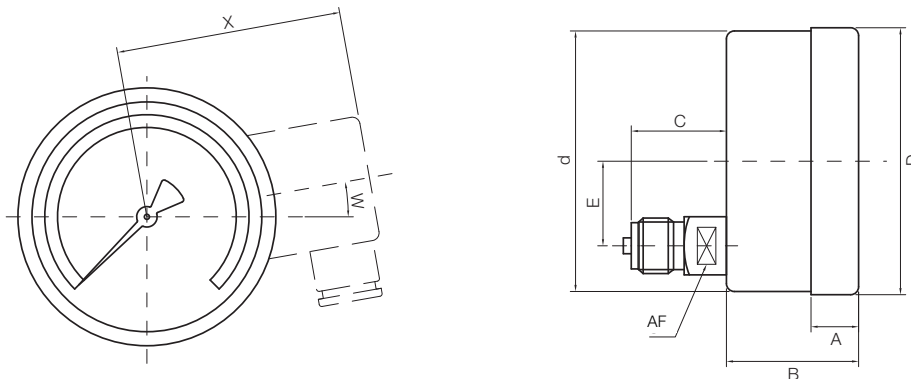



Dimensions

Triangular front ring with clamp

Code	NG	A	B without contact	B 1 or 2 contacts	B 3 contacts	B 4 contacts	C	d	D	E	AF	W	X
MAN-RD 23/73 B	63 mm	6	26	-	-	-	26	62	68	0	14	-	-
MAN-RE 24 K	80 mm	5	43.5	-	-	-	35	80	84	0	22	-	-
MAN-RF 24 K	100 mm VA	5	41	88	105	105	36	101	107	32.5	17	0	42
MAN-RF 34/64 K	100 mm Alu	5	41	88	105	105	34	100	107	32.5	27	0	42
MAN-RG 34/64 K	160 mm VA	5	45	98	145	145	30	160	162	50	22	0	42

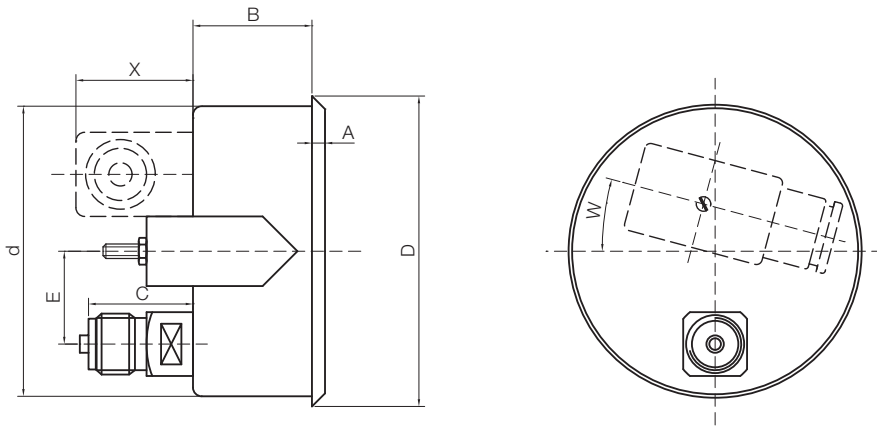

Front flange

Code	NG	A	B without contact	B 1 or 2 contacts	B 3 contacts	B 4 contacts	C	d	D	E	LK	S	AF	W	X
MAN-RD 23/73 V	63 mm	7	24	-	-	-	26	62	68	0	75	1	14	-	-
MAN-RF 24/74 V	100 mm VA	6	43	86	92	105	36	104	101	32.5	116	2	17	15	42
MAN-RF 34/64 V	100 mm Alu	5	40	86	102	102	34	100	100	32.5	116	2	27	15	42
MAN-RG 24/74 V	160 mm VA	6	43	95	110	110	34	164	161	32.5	178	2	17	15	42
MAN-RG 34/64 V	160 mm Alu	9	42	93	118	118	30	160	160	50	178	2	27	15	42

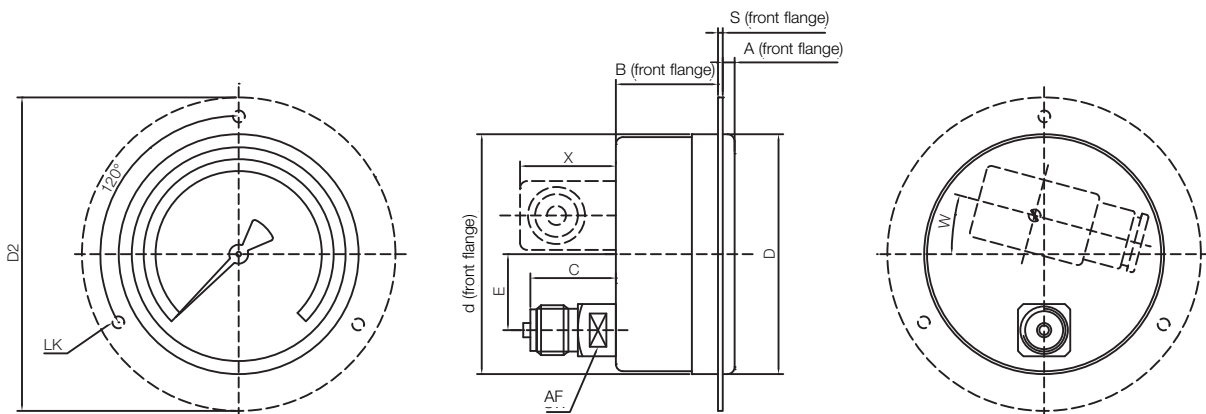



Dimensions

Rectangular casing

Code	NG	A	B without contact	B 1 or 2 contacts	B 3 contacts	B 4 contacts	C	d	D	E	AF	X
MAN-QF	96 x 96	9	40	81	85	92	34	90	96	32	17	42
MAN-QG	144 x 144	9	47	90	97	127	34	156	145	32	17	42

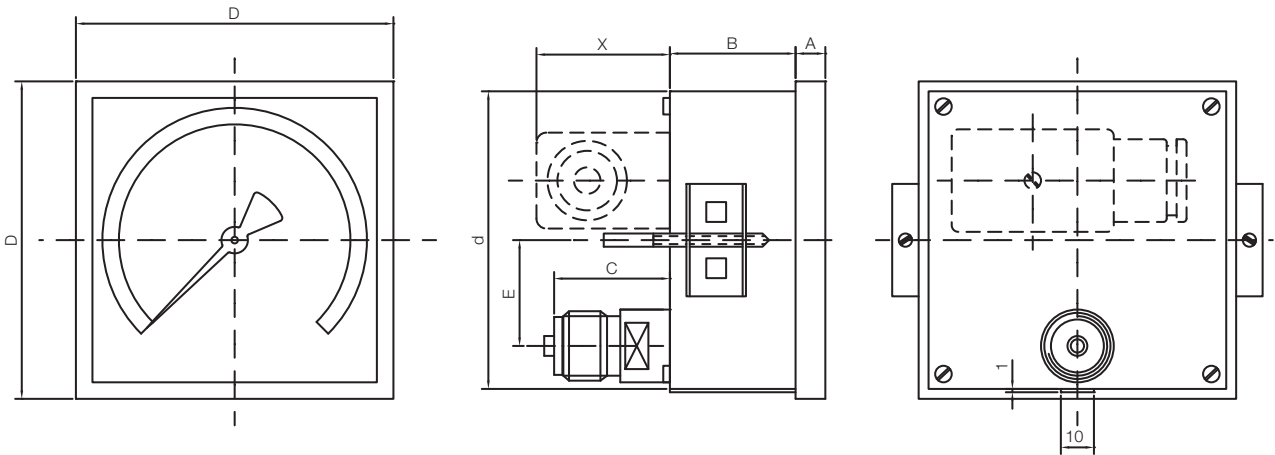

Weight

NG 63		without contact	up to 2 contacts	3 contacts	4 contacts
Code	Housing filling	Weight [kg]	Weight [kg]	Weight [kg]	Weight [kg]
MAN-RD 21	without	0.14	-	-	-
MAN-RD 23	without	0.15	-	-	-
MAN-RD 23 B	without	0.18	-	-	-
MAN-RD 23 V	without	0.18	-	-	-
MAN-RD 71	with	0.21	-	-	-
MAN-RD 73	with	0.22	-	-	-
MAN-RD 73 B	with	0.25	-	-	-
MAN-RD 73 V	with	0.25	-	-	-

NG 80					
MAN-RE 22	without	0.4	-	-	-
MAN-RE 24	without	0.4	-	-	-
MAN-RE 24 K	without	0.4	-	-	-
MAN-RE 24 V	without	0.4	-	-	-
MAN-RE 72	with	0.55	-	-	-
MAN-RE 74	with	0.55	-	-	-
MAN-RE 74 K	with	0.55	-	-	-
MAN-RE 74 V	with	0.55	-	-	-

NG 100					
MAN-RF 22	without	0.5	0.7	0.75	0.8
MAN-RF 24	without	0.5	0.7	0.75	0.8
MAN-RF 24 K	without	0.6	0.8	0.85	0.9
MAN-RF 24 V	without	0.6	0.8	0.85	0.9
MAN-RF 32	without	0.6	0.8	0.85	0.9
MAN-RF 34	without	0.7	0.9	0.95	1.0
MAN-RF 34 K	without	0.7	0.9	0.95	1.0
MAN-RF 34 V	without	0.7	0.9	0.95	1.0

NG 100 (continued)		without contact	up to 2 contacts	3 contacts	4 contacts
Code	Housing filling	Weight [kg]	Weight [kg]	Weight [kg]	Weight [kg]
MAN-RF 62	with	0.9	1.3	1.4	1.5
MAN-RF 64	with	1.0	1.4	1.5	1.6
MAN-RF 64 K	with	1.0	1.4	1.5	1.6
MAN-RF 64 V	with	1.0	1.4	1.5	1.6
MAN-RF 72	with	0.8	1.2	1.3	-
MAN-RF 74	with	0.8	1.2	1.3	-
MAN-RF 74 V	with	0.9	1.3	1.4	-

NG 160					
MAN-RG 22	without	1.0	1.3	1.4	1.5
MAN-RG 24	without	1.0	1.3	1.4	1.5
MAN-RG 24 V	without	1.1	1.4	1.5	1.6
MAN-RG 32	without	1.1	1.5	1.6	1.7
MAN-RG 34	without	1.2	1.5	1.7	1.8
MAN-RG 34 K	without	1.3	1.6	1.7	1.8
MAN-RG 34 V	without	1.3	1.6	1.7	1.8
MAN-RG 62	with	1.9	2.9	3.4	3.6
MAN-RG 64	with	1.9	2.9	3.4	3.6
MAN-RG 64 K	with	2.0	3.0	3.5	3.7
MAN-RG 64 V	with	2.0	3.0	3.5	3.7
MAN-RG 72	with	1.8	2.8	3.2	-
MAN-RG 74	with	1.8	2.8	3.2	-
MAN-RG 74 V	with	1.9	2.9	3.3	-