



## Turbidity Probe

absorption principle



measuring  
•  
monitoring  
•  
analysing

ATL



- Inline real time process monitoring
- Superior sapphire window with no seals, gaps or crevices
- Concentration measurement insensitive to colour changes for ATL-N
- Extremely low maintenance
- CIP/SIP compatible
- All wetted material and surface finishes are certifiable



KOBOLD companies worldwide:

ARGENTINA, AUSTRIA, BELGIUM, BULGARIA, CANADA, CHILE, CHINA, COLOMBIA, CZECHIA, DOMINICAN REPUBLIC, EGYPT, FRANCE, GERMANY, GREAT BRITAIN, HUNGARY, INDIA, INDONESIA, ITALY, MALAYSIA, MEXICO, NETHERLANDS, PERU, POLAND, ROMANIA, SINGAPORE, SOUTH KOREA, SPAIN, SWITZERLAND, TAIWAN, THAILAND, TUNISIA, TURKEY, USA, VIETNAM

KOBOLD Messring GmbH  
Nordring 22-24  
D-65719 Hofheim/Ts.  
Head Office:  
+49(0)6192 299-0  
+49(0)6192 23398  
info.de@kobold.com  
www.kobold.com



**Description**

**ATL-F**

The Kobold Turbidity Probe ATL-F is a high-precision, single channel absorption probe. The probe uses the light in the visible (VIS) range at a selected wavelength of 430 nm. An optical filter on the lamp side adapts the wavelength for specific applications and allows colour measurements with great accuracy (e.g. phase separation beer/water) at 430 nm.

**ATL-N**

The Kobold Turbidity Probe ATL-N is a high-precision NIR single channel absorption probe. The ATL-N uses light in the Near Infrared (NIR) from 730...970 nm. The optical filter on the lamp side adapts the wavelength for specific applications and allows colour-insensitive concentration measurements in the near infrared range. The ATL-N probe comes with two different optical path lengths (OPL) for process versatility.

**General**

The ATL-F as well as the ATL-N are designed for direct use in inline applications or vessels. The installation can be carried out by a 25 mm long standard port or by one of the various optional adaption possibilities.

A precisely defined, constant light beam penetrates the process medium. The attenuation of the light intensity, caused by absorption and/or scattering by dissolved and undissolved substances, is detected by a hermetically sealed photodiode.

The seal-less, sapphire window design eliminates crevices and gaps to assure the highest level of sterility, cleanability and sensor integrity. The sapphire window provides superior resistance to all abrasive and corrosive media. The probe body demonstrates extreme durability and fulfils the CIP/SIP requirements demanded by ultra-sanitary process environments.

**Application Areas**

**ATL-F**

- Phase separation
- e.g. in breweries

**ATL-N**

- Phase separation
- yeast - beer
- milk – water

concentration measurement (e.g. yeast dosage)

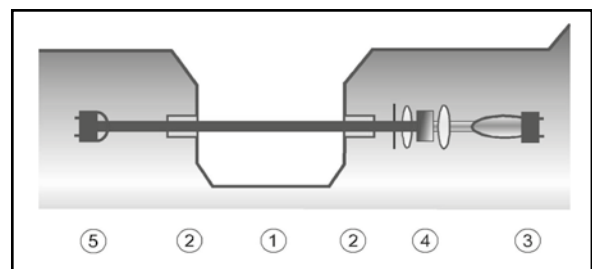

**Sensor Schematic**

- 1 Optical path length (OPL)
- 2 Sapphire windows
- 3 Lamp
- 4 Optics module with filter
- 5 Detector



**Technical Data**

Measuring principle:	absorption	Port connection:	for ports AS25-GS60 (similar to Ingold-Ports) diameter: 25 mm (Ø 25 H7) nominal length: 60 and 30 mm thread: G1¼" ISO 228/1						
Measuring range:	sensor specific 0 - 1 CU for ATL-F  freely selectable 0 - 3 CU for ATL-N	Insertion depth maximal:	OPL + 35 mm with port length 60 mm						
Permitted process temperature TS:	permanent: 0 ... 90 °C, (32 ... 194 °F)  peak (60 min/day): 0 ... 100 °C, (32 ... +212 °F)	Opt. path length (OPL):	5 or 10 mm						
Ambient temperature:	operation: 0 ... 40 °C, (32 ... 104 °F)  transportation: -20 ... +70 °C, (-4 ... +158 °F)	Air purge:	connection M5 available as standard						
Pressure rating:	PN10 (test pressure PT 15 bar)	Light source:	incandescent tungsten lamp: 5.0 V <sub>DC</sub> , 775 mA						
Permitted pressure PS:	10 mbar - 10 bar with TS 0 °C / +90 °C	Wavelength range:	430 nm for ATL-F 730 - 970 nm for ATL-N						
Permitted pressure at elevated temperature:	<table border="1"> <tr> <td>TS (°C)</td> <td>&lt;90</td> <td>100</td> </tr> <tr> <td>PS (bar)</td> <td>10</td> <td>8</td> </tr> </table>	TS (°C)	<90	100	PS (bar)	10	8	Detector:	silicone photodiode, hermetically sealed
TS (°C)	<90	100							
PS (bar)	10	8							
		Cable connection:	probe cable ASx6-TT, end splice on both sides probe cable ASx6-SCT, with stainless steel plug and socket 2, 3, 5, 10, 15, 20, ... 45 or 50 m (7, 10, 16, 33, 49, 66, ... 148 or 164 ft.)						
<b>Material</b>									
Wetted parts:	stainless steel 1.4435 (SS 316 L)	Weight:	probe: approx. 2.0 ... 2.5 kg, depending on version cable set: approx. 1.5 kg / 10 m						
Surface:	electro-polished Ra < 0.8 µm (standard)	Protection:	IP65						
Windows:	sapphire (without gasket)	Certificates:	ISO 9001:2000, PED, CE, HPO						
Housing:	stainless steel 1.4571 (SS 316 Ti)								
Adapter:	stainless steel 1.4435 (SS 316L)								
Port gasket:	O-ring Ø 18.64 x 3.53 mm								
Gasket material:	application specific, selection by end user  permitted: EPDM (FDA), silicone (FDA), Kalrez® 6375, Chemraz® (FDA), others on request								



**Order Details Probe** (Example: ATL- F E A)

Model	Wavelength	Gasket	Optical path length
ATL-*	F = 430 nm N = 730 - 970 nm (NIR)	E = EPDM (FDA) I = silicone (FDA) K = Kalrez® 6375 C = Chemraz® (FDA) X** = other material on request	A = OPL 5 mm B = OPL 10 mm

\* The connection cable between probe and converter and between the adapter has to be separately ordered as accessories.

\*\* Please specify material when ordering.

**Order Details Adapter** (Example: ATL- Z T50)

Model	Adapter	
	Connection	Size
ATL-Z	T50 = Tri Clamp® 2" V50 = Varivent® d = 68 mm S90 = weld-in port 90°, cone S9K = weld-in port 90°, short S15 = weld-in port 15°	
	R1 = T-piece with tube, according to DIN 11850  R2 = TT-piece with tube OD, according to BS 4825	9 = DN50 / 2" 0 = DN65 / 2 1/2" B = DN80 / 3" C = DN100 / 4" D = DN125 / 5" E = DN150 / 6"

**Order Details Zubehör**

Model	Description
ATL-ZK -10 ATL-ZK-20 ATL-ZK-30 ATL-ZK-40 ATL-ZK-50	connection cable between probe ATL and evaluation electronics ATT-K Length available in steps of 5 meter
ATL-ZF	sealing flange for probe connection

### Converter for 1-Channel Absorption Probe



#### Description

The Kobold converter model ATT-K combined with the probe ATL provides continuous inline, real-time measurement and control of concentrations, colour changes or turbidity in a variety of industrial processes.

With four fixed measuring ranges and one variable measuring range, the converter can be set to match your specific process parameters. The 3-digit LED indicator displays the percentage of the selected measuring range.

Two independent setpoints and one mA output are provided by the converter for alarms and real-time process monitoring when wired to the plant's process control system. An additional failsafe relay output is built in for remote sensing of lamp or power failure.

#### Technical Details

Measuring range:: 0-1 CU, 0-2 CU, 0-3 CU, 0-4 CU, variable 0-0.5...4 CU (factory-set 0-0.5 CU)

Resolution: < ±0.5 % of respective measuring range

Repeatability: < ±1 % of respective measuring range

Linearity: specific to application, < ±2 % of respective measuring range

Response time: 1 second

#### Ambient temperature

Operation: 0...50 °C (32...122 °F), no direct light

Transport: -20...+70 °C (-4...+158 °F)

Housing: 19" version for rack mounting, 3HE / 21 TE

dimensions  
106 x 116 x 190 mm (W x H x D)

Weight 2.0 kg

Display: digital, 3-digits

Alarm output: 2 independent adjustable SPDT contacts

Failsafe: 1 contact to alarm in case of lamp or system failure (active)

Cable lengths: combined with ATL max. 50 m (max. 164 ft.)

Output: 0/4 - 20 mA (galvanically isolated)

Load: max. 500 Ω

Power supply: 115 / 230 V<sub>AC</sub> selectable or 24 V<sub>AC/DC</sub>

Power consumption: 30 VA

Protection: front IP40 / rear IP20 when mounting in optional available field housing higher protection is possible

Certificates: CE, GS

#### Order Details Converter (Example: ATT-K A E C 1)

Model	Measuring principle	Housing	Unit	Power supply
ATT-K*	A = absorption	E = panel mounting F = field housing	C = CU	1 = 115 / 230 V <sub>AC</sub> switchable 2 = 24 V <sub>AC/DC</sub>

\* The connection cable between probe and converter has to be separately ordered as accessories.

**Abmessungen**

**Sensor ATL-F / -N**

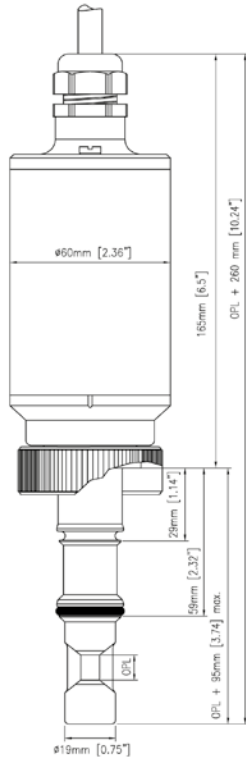

**Adapter Tri-Clamp® 2" (ATL-ZT50)**

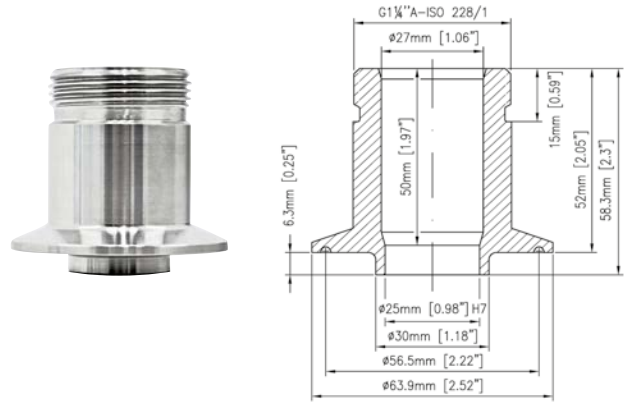

**Adapter Varivent®, d = 68 mm (ATL-ZV50)**

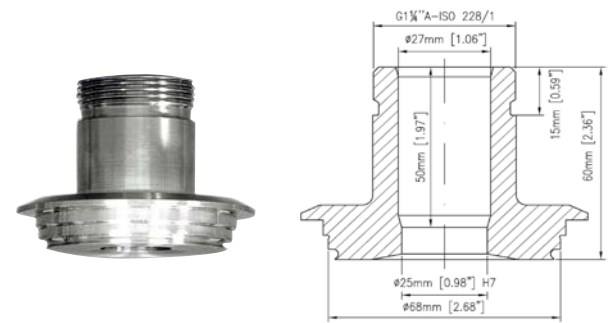

**Weld-in port 90°, cone (ATL-ZS90)**



**Weld-in port 90°, short (ATL-ZS9K)**

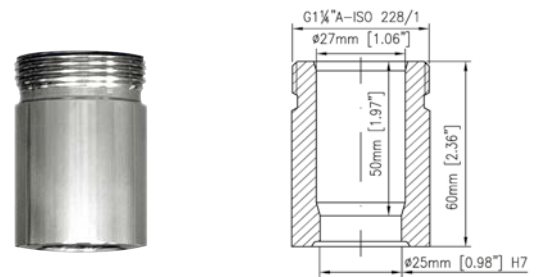

**Weld-in port 15° (ATL-ZS15)**

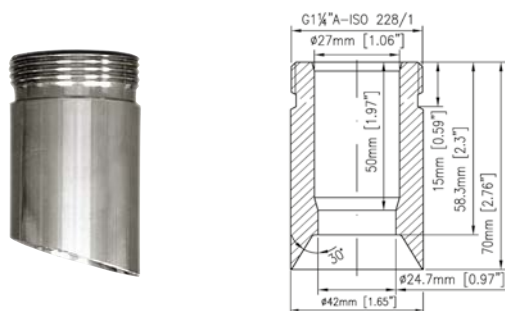

**Sealing flange for probe connection (ATL-ZF)**

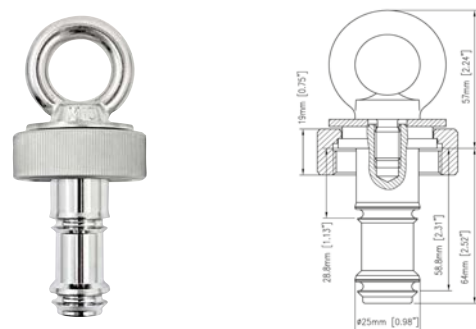

**Adapter T-piece with tube according to DIN 11850  
respectively with tube OD according to BS4825 (ATL-ZR...)**

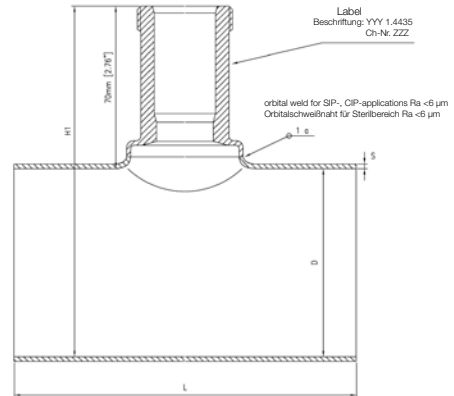
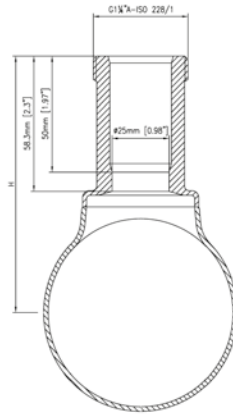

**Permitted Pressure at Elevated Temperature**

**ATL-ZR1**

TS [°C]	≤120	150	200
PS [bar]	16	14	13

**ATL-ZR2**

TS [°C]	≤120	150	200
PS [bar]	20	18	16

**Dimensions and maximum OPL of the Probe for T-piece with Tube according to DIN11850**

Nominal diameter	Length L [mm]	Tube size $\varnothing \times S$ [mm]	Inner- $\varnothing$ D [mm]	Height H [mm]	Depth H1 [mm]	Maximal OPL [mm]	Model
DN50	150	53.0 x 1.5	50.0	94.5	120	20	ATL-ZR19
DN65	150	70.0 x 2.0	66.0	103.0	136	20	ATL-ZR10
DN80	150	85.0 x 2.0	81.0	110.5	151	40	ATL-ZR1B
DN 100	250	104.0 x 2.0	100.0	120.0	170	40	ATL-ZR1C
DN 125	250	129.0 x 2.0	125.0	132.5	195	40	ATL-ZR1D
DN 150	250	154.0 x 2.0	150.0	145.0	220	40	ATL-ZR1E

**Dimensions and maximum OPL of the Probe for T-piece with Tube OD according to BS4825**

Nominal diameter	Length L [mm]	Tube size $\varnothing \times S$ [mm]	Inner- $\varnothing$ D [mm]	Height H [mm]	Depth H1 [mm]	Maximal OPL [mm]	Model
2.0"	150	50.8 x 1.65	50.0	94.5	120	20	ATL-ZR29
2.5"	150	63.5 x 1.65	66.0	103.0	136	20	ATL-ZR20
3.0"	150	85.0 x 1.65	81.0	110.5	151	40	ATL-ZR2B
4.0"	250	104.0 x 2.0	100.0	120.0	170	40	ATL-ZR2C
5.0"	250	129.0 x 2.0	125.0	132.5	195	40	ATL-ZR2D
6.0"	250	154.0 x 2.0	150.0	145.0	220	40	ATL-ZR2E

**Converter with Panel Mounting Housing ATT-KAE**

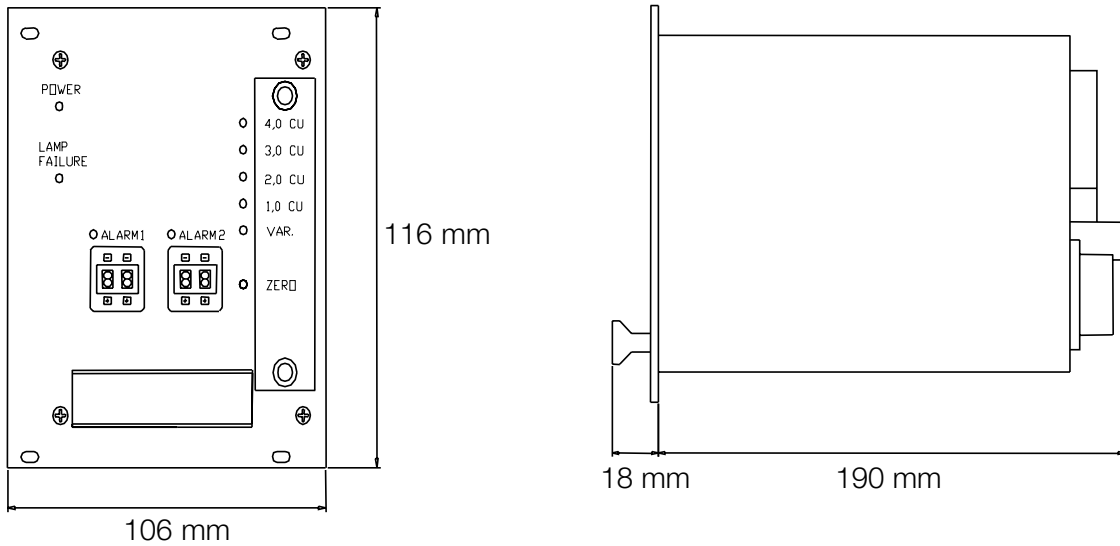

**Converter with Field Housing ATT-KAF**

