



Paddle Bellows Flow Monitor for Liquids



measuring
•
monitoring
•
analysing

DWU



- Measuring ranges: 1-5 l/min... 900-3 600 m³/h water
- Measurement accuracy: ±3 ... ±5% f. s.
- Connection: G 3/8" ... G 2, 3/8" NPT ... 2" NPT
flange: DN 10 ... DN 50
ANSI 3/8" ... 2"
Weld-on flange for pipe cross-section: DN 40 ... DN 500
- Material: brass, PVC or stainless steel
- p_{max}: PN 16; t_{max}: 100 °C
- For fouled media
- Universal mounting

SS



KOBOLD companies worldwide:

ARGENTINA, AUSTRALIA, AUSTRIA, BELGIUM, BULGARIA, CANADA, CHILE, CHINA, COLOMBIA, CZECHIA, EGYPT, FRANCE, GERMANY, GREAT BRITAIN, HUNGARY, INDIA, INDONESIA, ITALY, MALAYSIA, MEXICO, NETHERLANDS, PERU, POLAND, REPUBLIC OF KOREA, ROMANIA, SINGAPORE, SPAIN, SWITZERLAND, TAIWAN, THAILAND, TUNISIA, TURKEY, USA, VIETNAM

KOBOLD Messring GmbH
Nordring 22-24
D-65719 Hofheim/Ts.
Head Office:
+49(0)6192 299-0
+49(0)6192 23398
info.de@kobold.com
www.kobold.com

Description

The new KOBOLD flow indicator and monitor DWU works according to the diaphragm plate principle. Baffle/paddle (1) is deflected in the flow direction against the force of the spring (2) by the flowing medium.

A stainless steel bellows (3) seals off the system hermetically between medium and measuring unit/indicator.

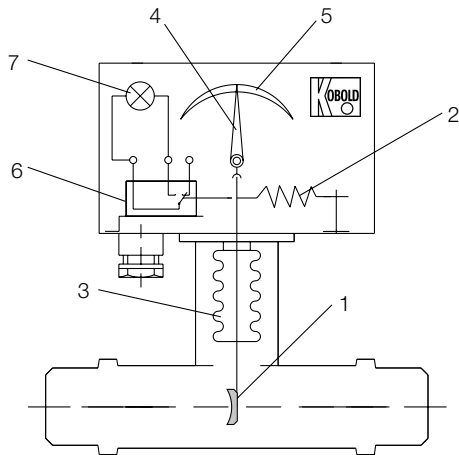

The motion is transferred positively from the baffle (1) to the measuring section.

The actual flow rate is displayed in l/min or m³/h on the dial (5) by the pointer (4). In the measuring section a microswitch (6) and a pilot lamp (7) are operated as soon as the set switching point is exceeded or undershot. Thus the change in flow is clearly signalled locally by the switching point pilot lamp (illuminates for undershooting). At the same time switching operations are triggered by the microswitch, designed as a 3-pole changeover contact.

The displacement-deflection technique is one of the most secure systems available as motion is transferred positively from the baffle plate to the measuring section. With these flow monitors if the T piece becomes clogged up with lime, foreign objects or dirt, the system responds with "no flow". It is practically impossible for the system to hang up in a position that indicates flow when there is in fact no flow.

Recommended inlet and outlet pipe section

Upstream of measuring instrument linear flow = 10 x d
 Downstream of measuring instrument linear flow = 5 x d
 d = effective pipe cross-section

Areas of Application

- Heavy goods industry
- Rolling mills and mill trains
- Chemicals and pharmaceuticals industries
- Drinks and semi-luxury food industry
- General mechanical engineering and capital equipment
- Measurement and monitoring of product, cooling and lubricant circuits

Technical Data

Device part	Material combination		
	5	6	7
T piece	Brass	Stainl. steel	PVC
Connecting thread	Brass	Stainl. steel	PVC
Connecting flange	Steel zinc-plated	Stainl. steel	PVC
Weld-on flange	Steel sprayed	Stainl. steel	Boring pipe box PVC
Paddle system	Brass	Stainl. steel	Stainl. steel
Bellows	Stainl. steel	Stainl. steel	Stainl. steel
Seals	FPM	FPM	FPM
Case meas. section	Stainl. steel	Stainl. steel	Stainl. steel
Covering hood	Polycarbonate	Polycarbonate	Polycarbonate
t _{max} *	100 °C	100 °C	20 °C (60 °C)
p _{max} *	16 bar	16 bar	16 bar (2 bar)

*Higher upon request

- Flow ratio: thread connection: max.1:5
 mounting flange: max.1:4
- Repeat accuracy up: up to 20 l/min: ±5%
 21-200 l/min: ±4%
 201 and more l/min: ±3%
 (based on calibration position and medium at 20 °C)
- Pressure loss: 0.1 - 0.3 bar (average pressure loss, value upon request)
- Switching hysteresis up: up to 2 bar 10%
 depending on pressure
- Ambient temperature: max. 70 °C
- Electrical switching capacity: 250 V / 10 A
- Pilot lamp: 230 V_{AC}, 110 V_{AC} or 24 V_{DC}
- Protection type: IP55 (IP65 upon request)
- EX version:
 Option X:  II 2G EEx d IIC T6 (switch)
 Option G: gold-plated contact for intrinsically safe operation

Mounting position

Due to the positive indication and transmission, the devices can be mounted in all mounting positions – however they must be calibrated for the chosen position. The devices should therefore be mounted in the mounting and calibration position specified on the nameplate, whereby the mounting position refers to the piping run.

Installing the devices in positions other than those specified on the nameplate causes measurement inaccuracies. The direction of flow is indicated on the device. Should the medium flow in the opposite direction the device will not operate correctly.



Order details (Example: **DWU-15 R10 0 R T 0**)

We require the following details as well as the order number:
medium, viscosity, service temperature, operating pressure, flow range within the values detailed below with the ratio min/max 1:5 (and 1:4 for type DWU-3...)

Flow monitor model DWU-1.. with male thread connection

Flow range [l/min]		Material combination (bellows/T piece)			Connection male thread	Pilot lamp	Direction of flow	Location of indicator	Option
min. water	max. water	st. steel/brass	st. steel/st. steel	st. steel/PVC					
1	25	DWU-15..	DWU-16..	DWU-17..	R10 = G 3/8 N10 = 3/8" NPT	0 = 230 V _{AC} 1 = 110 V _{AC} 3 = 24 V _{DC} X = without pilot lamp	R = from right to left L = from left to right	T = above lead	0 = without D = with damping G = gold plated contacts X = Ex-contact* 2 = Twin contact *at Ex-contact without pilot lamp
1	55	DWU-15..	DWU-16..	DWU-17..	R15 = G 1/2 N15 = 1/2" NPT				
5	100	DWU-15..	DWU-16..	DWU-17..	R20 = G 3/4 N20 = 3/4" NPT				
6	150	DWU-15..	DWU-16..	DWU-17..	R25 = G 1 N25 = 1" NPT		T = from top to bottom	R = right of lead	
10	250	DWU-15..	DWU-16..	DWU-17..	R32 = G 1 1/4 N32 = 1 1/4" NPT		B = from bottom to top	L = left of lead	
20	400	DWU-15..	DWU-16..	DWU-17..	R40 = G 1 1/2 N40 = 1 1/2" NPT				
50	600	DWU-15..	DWU-16..	DWU-17..	R50 = G 2 N50 = 2" NPT				

Flow monitor model DWU-2.. with flange connection

Flow range [l/min]		Material combination (bellows/T piece)			Connection flange	Pilot lamp	Direction of flow	Location of indicator	Option
min. water	max. water	st. steel/brass	st. steel/st. steel	st. steel/PVC					
1	25	DWU-25..	DWU-26..	-	F10 = DN 10 A10 = 3/8" ANSI	0 = 230 V _{AC} 1 = 110 V _{AC} 3 = 24 V _{DC} X = without pilot lamp	R = from right to left L = from left to right	T = above lead	0 = without D = with damping G = gold plated contacts X = Ex-contact* 2 = Twin contact *at Ex-contact without pilot lamp
1	55	DWU-25..	DWU-26..	-	F15 = DN 15 A15 = 1/2" ANSI				
5	100	DWU-25..	DWU-26..	-	F20 = DN 20 A20 = 3/4" ANSI				
6	150	DWU-25..	DWU-26..	DWU-27..	F25 = DN 25 A25 = 1" ANSI		T = right of lead	R = rechts v. d. Leitung	
10	250	DWU-25..	DWU-26..	DWU-27..	F32 = DN 32 A32 = 1 1/4" ANSI		B = left of lead	L = links v. d. Leitung	
20	400	DWU-25..	DWU-26..	DWU-27..	F40 = DN 40 A40 = 1 1/2" ANSI				
50	600	DWU-25..	DWU-26..	DWU-27..	F50 = DN 50 A50 = 2" ANSI				



Order details (continuation)

Flow monitor model DWU-35../DWU-36.. with weld-on flange / DWU-37.. with boring pipe box

Flow range [m³/h]		Material combination (bellows/connecting piece)			for pipe crossection	Pilot lamp	Direction of flow	Location of indicator	Option
min. water	max. water	st. steel/ steel	st. steel/ st. steel	st. steel/ PVC					
1.2	24	DWU-35..	DWU-36..	DWU-37..	W40 = DN 40	0 = 230 V _{AC} 1 = 110 V _{AC} 3 = 24 V _{DC} X = without pilot lamp	R = from right to left L = from left to right	T = above lead	0 = without D = with damping G = gold plated contacts X = Ex-contact* 2 = Twin contact *at Ex-contact without pilot lamp
3.0	36	DWU-35..	DWU-36..	DWU-37..	W50 = DN 50				
4.8	60	DWU-35..	DWU-36..	DWU-37..	W65 = DN 65				
7.2	90	DWU-35..	DWU-36..	DWU-37..	W80 = DN 80				
12	144	DWU-35..	DWU-36..	DWU-37..	W1H = DN 100				
18	225	DWU-35..	DWU-36..	DWU-37..	W1Z = DN 125				
24	330	DWU-35..	DWU-36..	DWU-37..	W1F = DN 150		T = from top to bottom B = from bottom to top	R = right of lead L = left of lead	
42	600	DWU-35..	DWU-36..	DWU-37..	W2H = DN 200				
72	900	DWU-35..	DWU-36..	-	W2F = DN 250				
102	1200	DWU-35..	DWU-36..	-	W3H = DN 300				
150	1800	DWU-35..	DWU-36..	-	W3F = DN 350				
180	2400	DWU-35..	DWU-36..	-	W4H = DN 400				
300	3600	DWU-35..	DWU-36..	-	W5H = DN 500				

Dimensions

DWU-1.. with thread connection

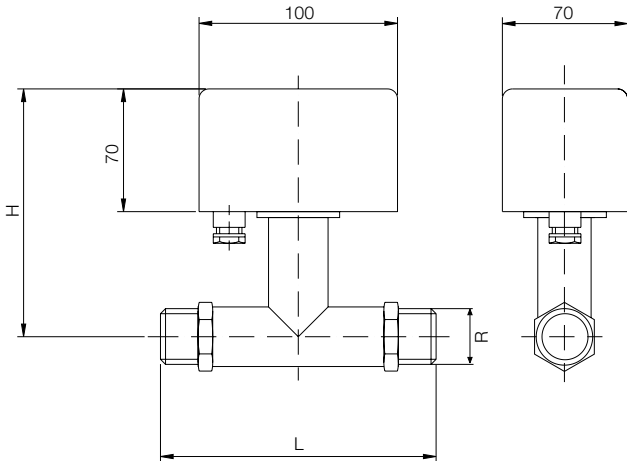

R	H [mm]	L [mm]
3/8	145+1	135+1
1/2	145+1	135+1
3/4	145+1	135+1
1	145+1	135+1
1 1/4	150+2	170+2
1 1/2	155+2	170+2
2	160+2	170+2

We kindly ask you to provide us with a separate inquiry for the exact dimensions of the material combination 7 (PVC).

DWU-2.. with flange connection

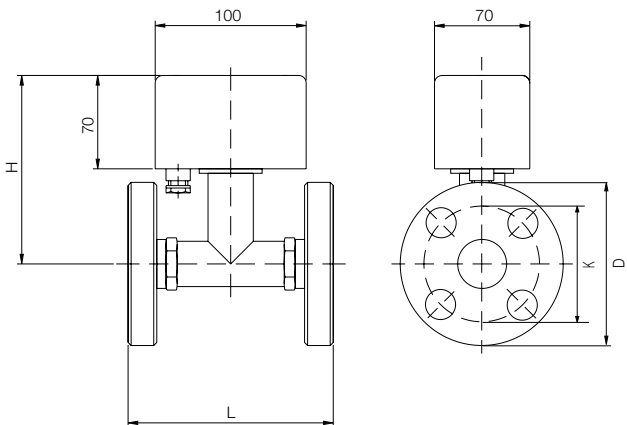

DN	D [mm]	K [mm]	H [mm]	L [mm]
10	90	60	145+1	155+2
15	95	65	145+1	155+2
20	105	75	145+1	160+2
25	115	85	145+1	160+2
32	140	100	150+2	190+2
40	150	110	155+2	190+2
50	165	125	160+2	190+2

We kindly ask you to provide us with a separate inquiry for the exact dimensions of the material combination 7 (PVC).

DWU-3.. with weld-on flange

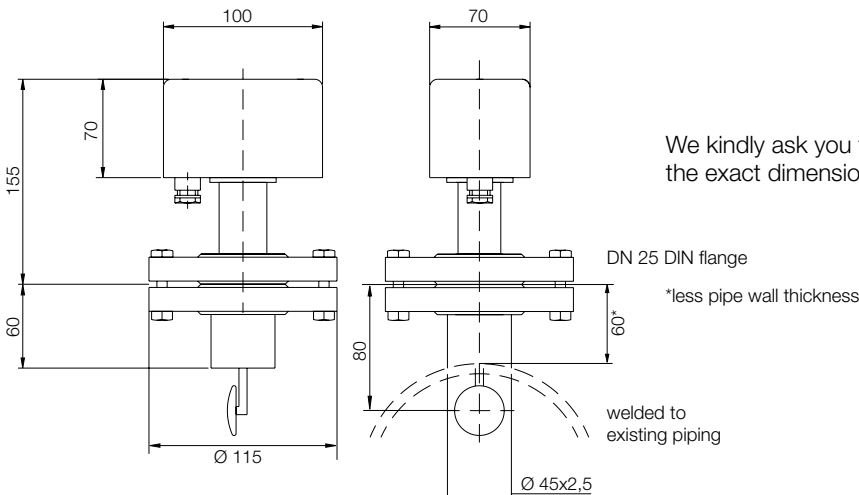

We kindly ask you to provide us with a separate inquiry for the exact dimensions of the material combination 7 (PVC).